

MAXIMUM PRODUCT LOAD RATING: 150 kg 

IMPORTANT:

- **LOAD = WEIGHT OF PLATFORM or BARS + MOUNTING SYSTEM + ACCESSORIES + CARGO**
- **PLEASE REFER TO VEHICLE MANUFACTURER SPECIFICATIONS FOR MAX ROOF LOAD CAPACITY OF VEHICLE. THE LOWEST LOAD RATING APPLIES.**
- **OFFROAD RATING: SCAN QR CODE FOR LOCKNLOAD LOAD RATING GUIDE. REDUCTIONS MAY APPLY.**



FIRST TIME INSTALLATION

- Please read instructions carefully before installation.
- Check the contents of kit. Each spine has the last four digits of the kit's part number lasered in.
- Contact your YAKIMA dealer if any parts appear missing, incorrect or damaged.
- Clean your roof thoroughly prior to fitting the LockNLoad RuggedLine.
- Place these instructions in the vehicle's glove box after installation is complete.



TOOLS REQUIRED:

- Trim Remover Tool (preferred) or Flat Head Screwdriver (with tape)
- 12 mm Socket Wrench
- 12 mm Breaker Bar (optional)
- Rattle Gun (optional)
- T45, T35, & T20 Torx bits
- 6 mm & 10 mm Socket

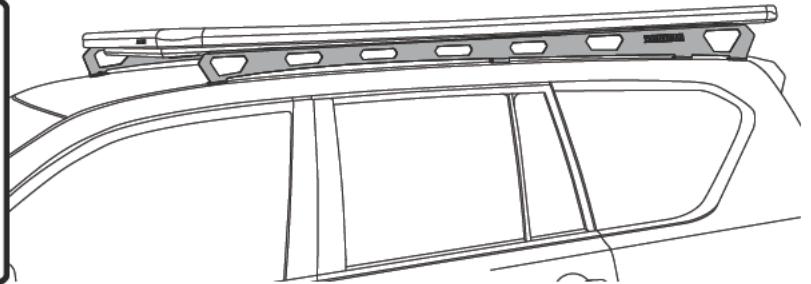

KIT CONTENTS

ITEM	COMPONENT	QTY	ITEM	COMPONENT	QTY
1.	Ford Everest RH Spine	x1	8.	M6 x 16 mm Washer	x8
2.	Ford Everest LH Spine	x1	9.	5 mm Hex Key Ball End Allen Key	x1
3.	Pivot Bracket Assembly	x6	10.	6 mm Hex Key Ball End Allen Key	x1
4.	M8 x 1.25 Nyloc Nut	x6	11.	Loctite 598	x1
5.	M8 Washer	x12	12.	M6 x 20 Button Head Capscrew	x2
6.	M8 x 20 Socket Head Capscrew	x6	13.	M6 x 12.5 x 1.2 Washer	x2
7.	M6 x 20 Capscrew Socket Head	x8			

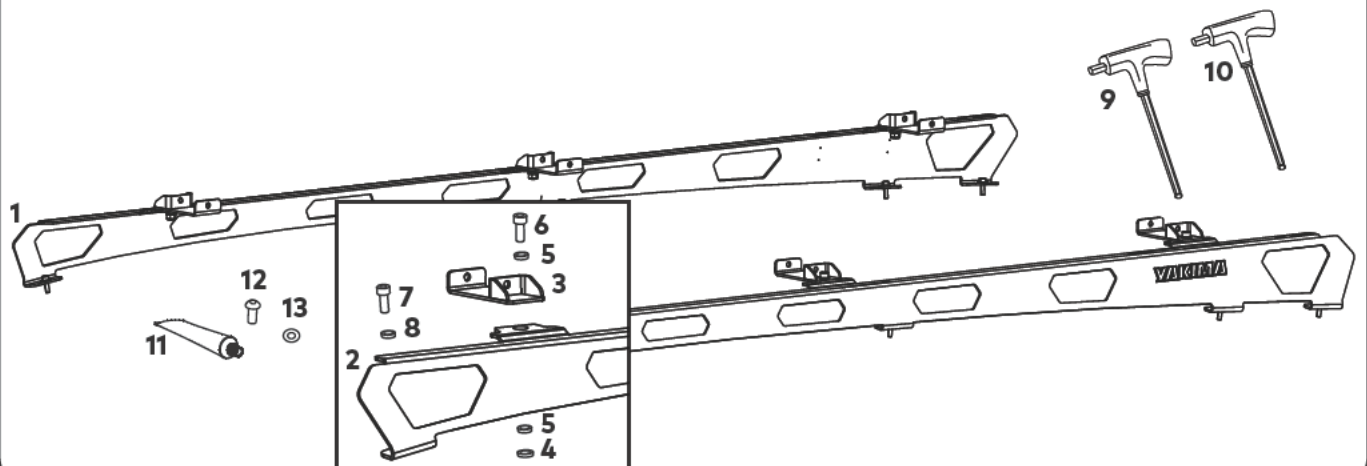

REMOVING FACTORY RAILS

1

REMOVE ROOF LINING (RECOMMENDED PROFESSIONALS ONLY)

Before the factory roof rails can be removed, you will need to arrange for the roof lining to be carefully removed to provide access to the rail nuts. These are only accessible from the underside of the roof.

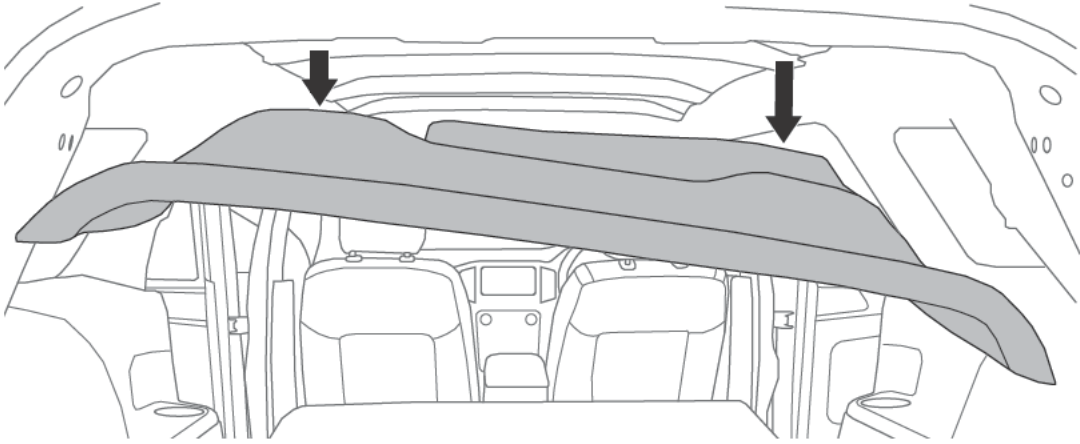

2

REMOVE RAIL HARDWARE

Once the lining has been removed, unscrew the factory nuts to remove the roof rails. There are 4x each side of vehicle, close to curtain airbag.

Nuts to be removed with 10mm socket wrench.

DO NOT DISCARD NUTS

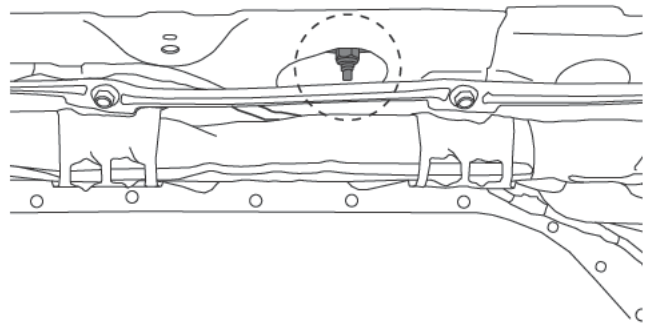

3

REMOVE RAILS

Carefully lift roof rails x2 directly upwards and remove from the roof.

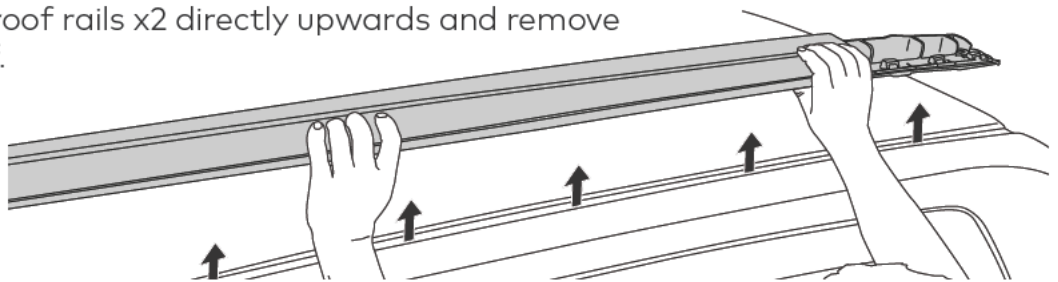

4

CLEAN ROOF

Wipe clean any dirt that may have built up in and around all mounting holes.

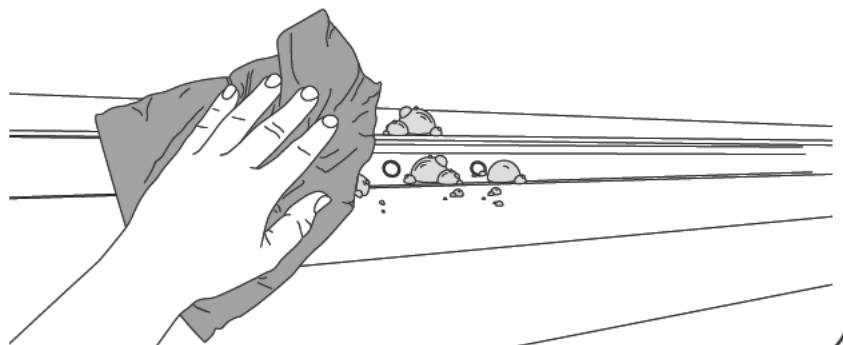

5 FILL IN THE FRONT HOLES

Fill in the front holes with 2 Button Head Capscrews.

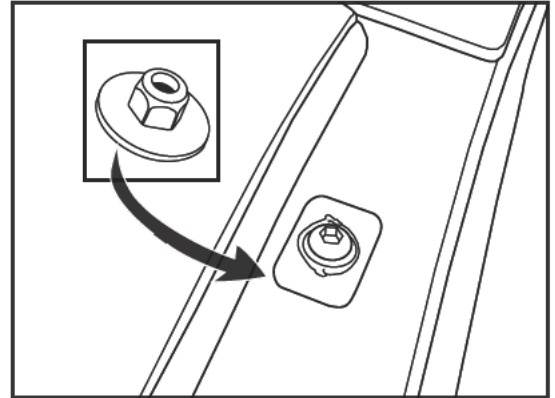
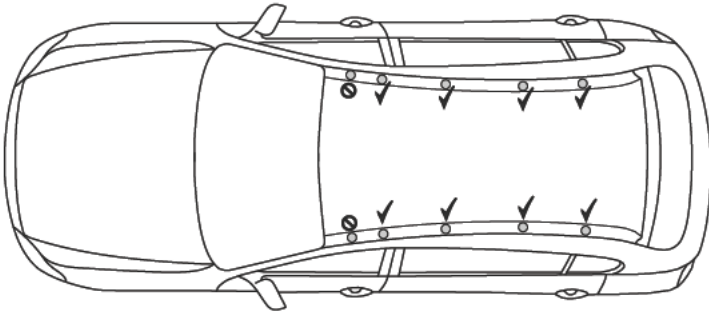

6 AFFIX FOAM ADHESIVE

Apply Foam Adhesive over remaining 8 mounting holes in the vehicle's fixed points, with adhesive side to vehicle.

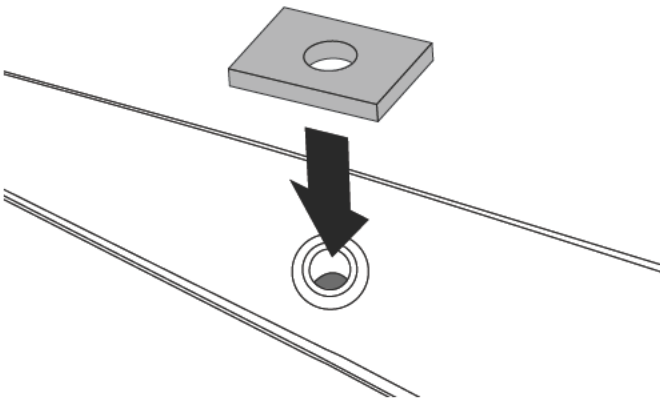

7 APPLY LOCTITE

Liberally apply the supplied Loctite 598 to the inside surface and on top of each hole **on one side of vehicle**.

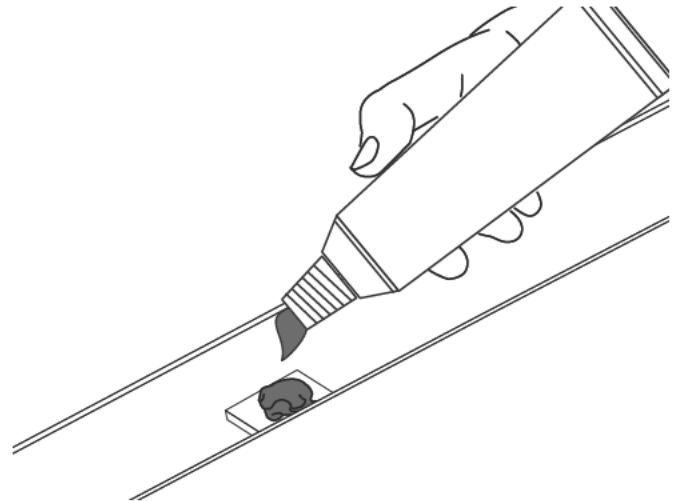

8 POSITION RUGGEDLINE ON VEHICLE ROOF

Referring to the left-right orientation on top of each Spine, carefully place one side of the RuggedLine onto vehicle roof as shown. Line up the mounting holes on the bottom tabs to those exposed on the roof. The tabs are to face in towards the vehicle.

Front of vehicle

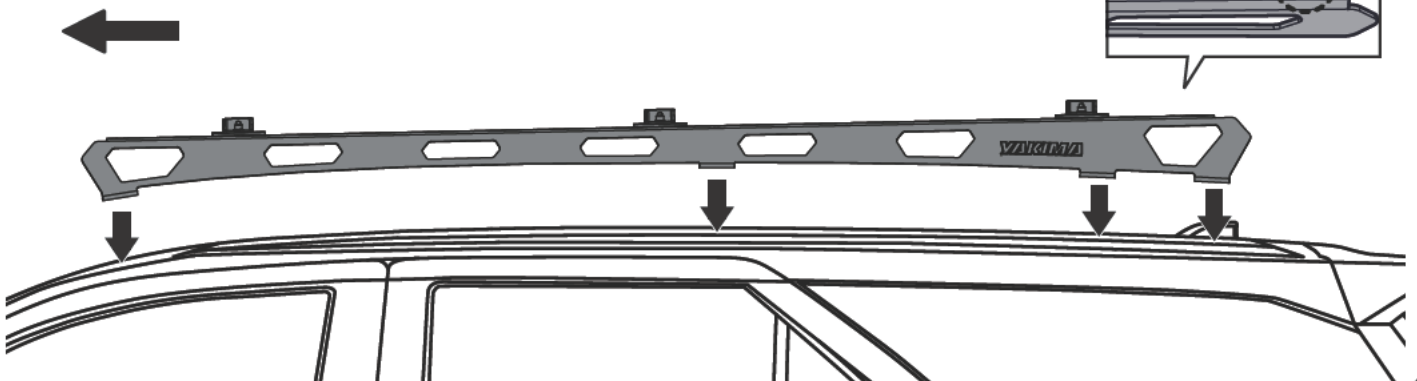

9 INSERT BOLTS

Insert M6 bolts into feet of spines to car.

RECOMMENDED TO USE LOCTITE 243 OR EQUIVALENT

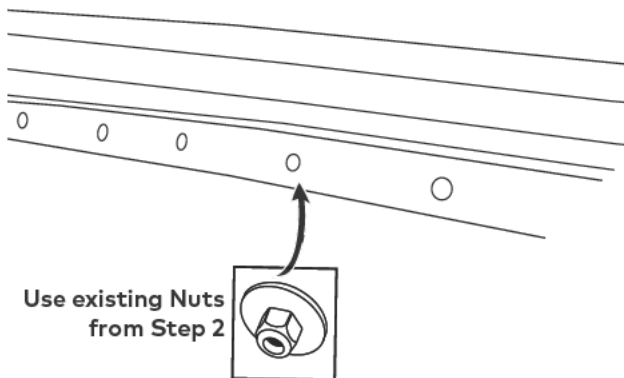
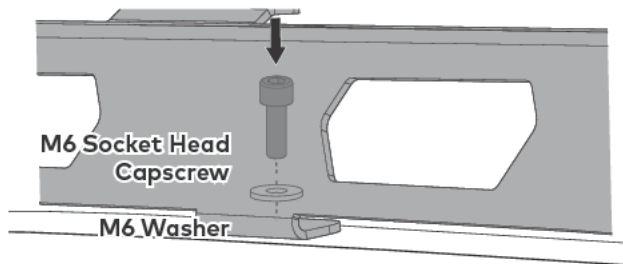

10 TIGHTEN BOLTS

Using the socket wrench hold the bolt in place while screwing from above.

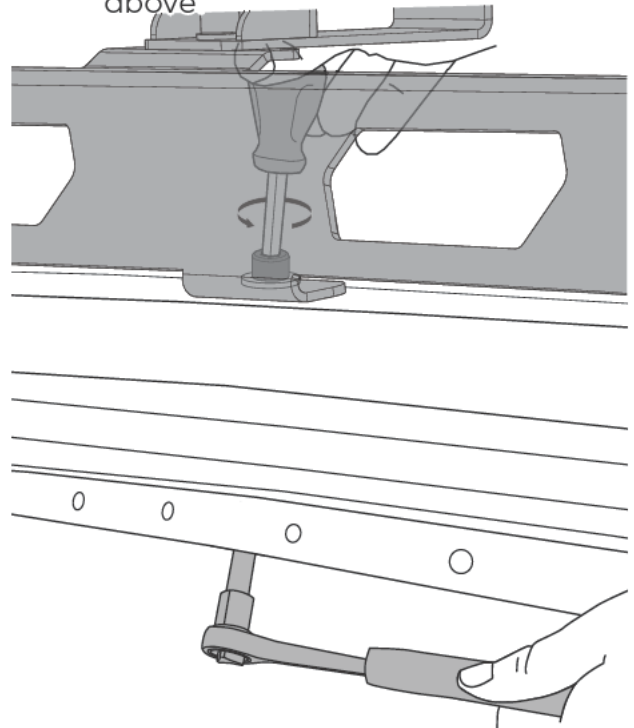

11 TIGHTEN RUGGEDLINE HARDWARE

Using the 5 mm T Handle Ball End Allen Key, and avoiding damage to the powder coat, start to carefully secure the RuggedLine by tightening the M6 Socket Head Capscrews to 7 Nm into the mounting holes in roof.

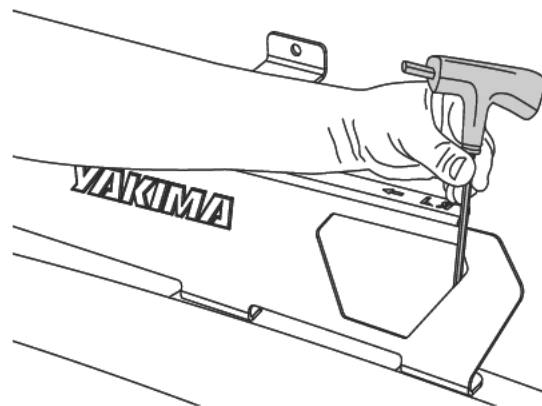

12 REPEAT STEPS ON OPPOSITE SIDE

Repeat steps 6-10 on pages 3 for securing opposite side of RuggedLine Spine.

Ensure both Spines are securely positioned on vehicle roof. Check each screw is secure before proceeding to install LockNLoad Platform to RuggedLine Spines.

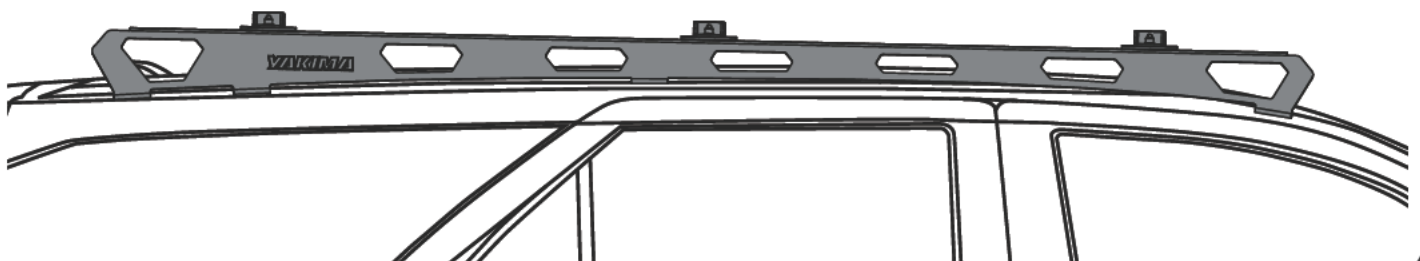

REPLACE ROOF LINING

13

REFIT ROOF LINING (RECOMMENDED PROFESSIONALS ONLY)

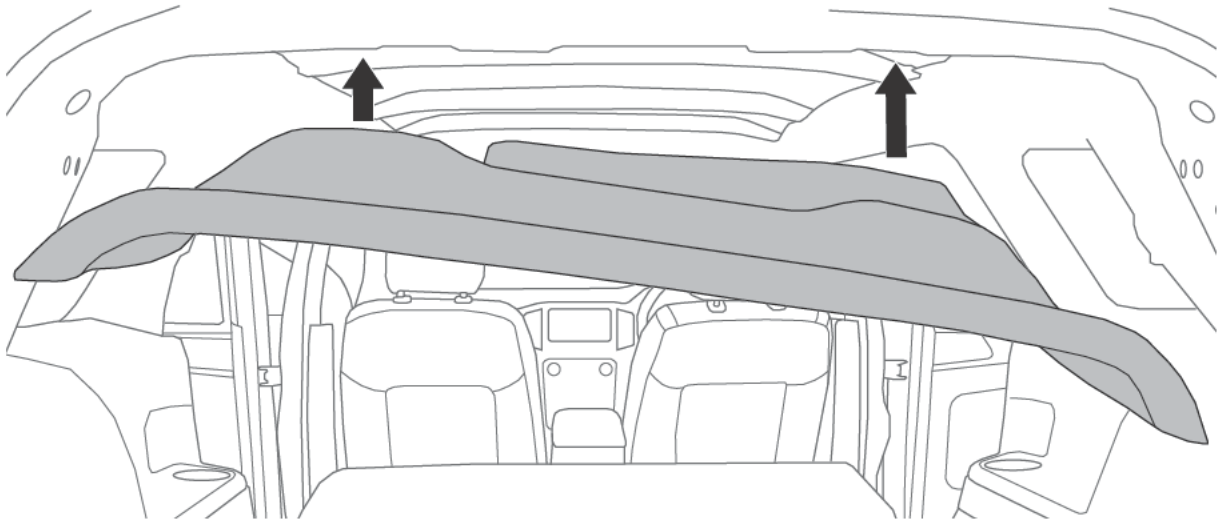

14

ASSEMBLE PIVOT BRACKET TO RUGGEDLINE

Assemble Pivot Bracket and M8 hardware as pictured. Complete this for both M8 mounting holes on top of the RuggedLine Spine.

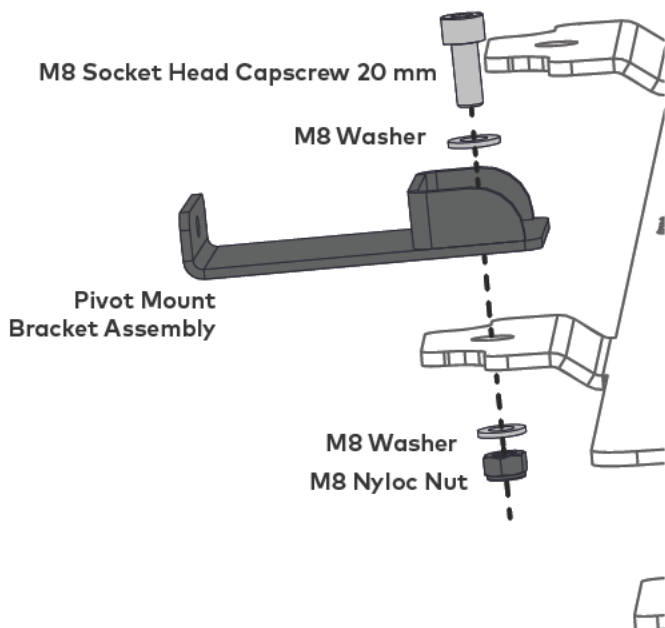

15

SECURE PIVOT BRACKET ASSEMBLIES

Tighten all Capscrews with the provided 6 mm T Handle Ball End Allen Key, and all Nuts with a 13 mm Spanner or a suitable Torque Wrench.

Ensure all Capscrews and Nuts are tightened to 7 Nm.

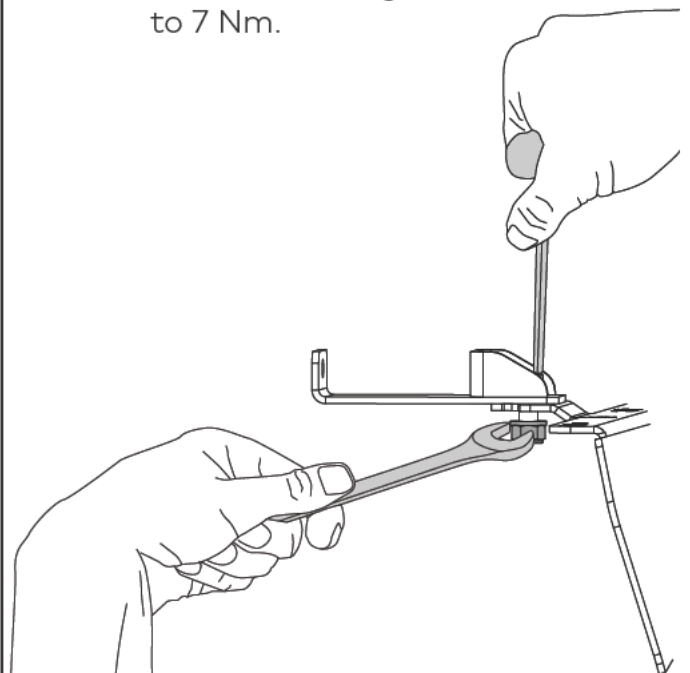

16**INSTALL PLATFORM PIVOT MOUNTS**

From the LockNLoad Platform kit (sold separately), position Pivot Mounts into each Pivot Bracket Assembly, lining up the rivnut holes on the Mounts with the holes on the brackets.

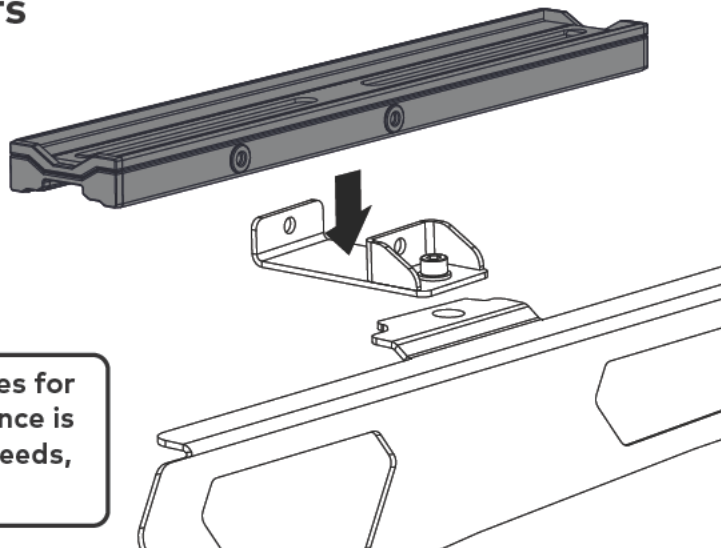

Where possible, always use the centre holes for attaching to Pivot Bracket. If extra clearance is needed due to Platform-to-roof fitment needs, the offset holes can be used.

17**SECURE PLATFORM PIVOT MOUNTS**

Secure all Platform Pivot Mounts with 2x 16 mm M6 Capscrews with Washer from LockNLoad Platform kit as shown.

Tighten all Capscrews to 4 Nm with the provided 4 mm Ball End Allen Key or a suitable Torque Wrench.

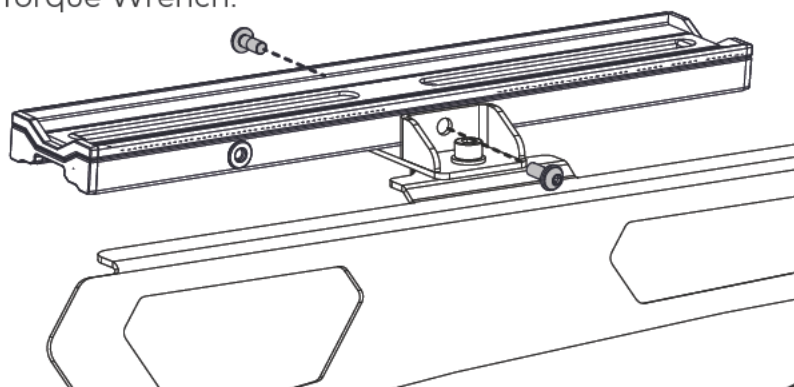

NOTE - The Pivot Mount assembly will still have movement after securing which is intended.



NOW SWITCH TO YOUR LOCKNLOAD PLATFORM INSTRUCTIONS AND CONTINUE FROM THE 'VEHICLE MOUNTING INSTRUCTIONS' PAGE.

YAKIMA

www.yakima.com.au

www.yakima.co.nz

www.yakima.com

www.yakima.eu

YAKIMA AUSTRALIA PTY LTD

17 Hinkler Court
Brendale, QLD 4500
Australia
1800 143 548

YAKIMA PRODUCTS, INC.

4101 Kruse Way
Lake Oswego, OR
97035-2541
USA
888 925 4621

ALL CONTENT SUBJECT TO YAKIMA AUSTRALIA PTY LTD COPYRIGHT © 2023