

YAKIMA LUGGAGE BOX

SpaceBooster
RocketBox
SpaceCase

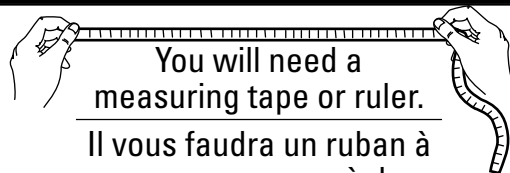

You will need a measuring tape or ruler.

Il vous faudra un ruban à mesurer ou une règle.

Necesitará una cinta métrica o regla.

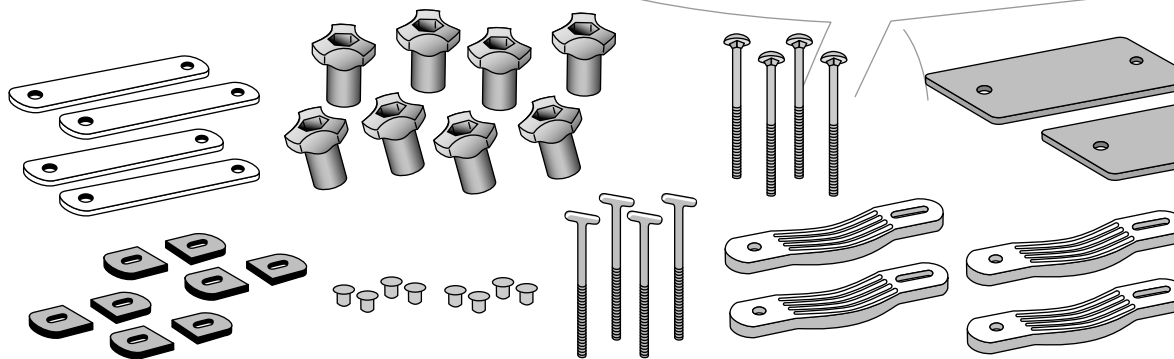
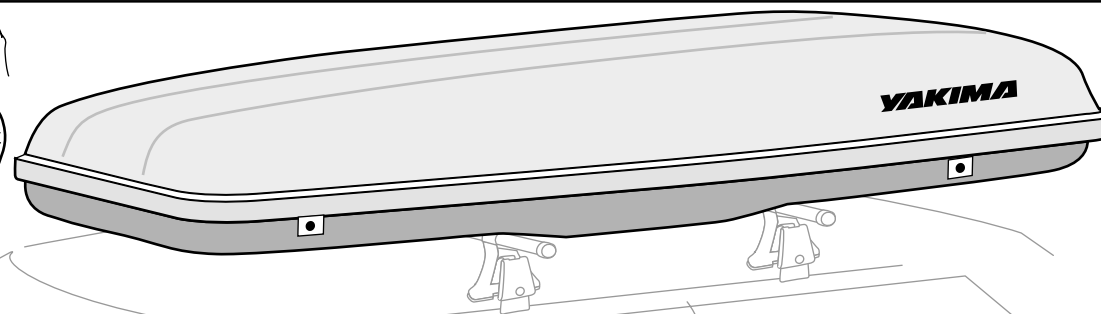

CURVED BRACKETS

ÉTRIERS

PIEZAS DE SUJECIÓN CURVAS

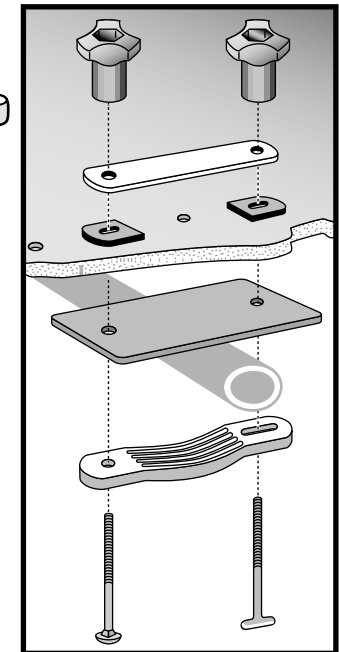

**MAXIMUM LOAD LIMITS:
CHARGE MAXIMALE:
LIMITES MAXIMOS DE CARGA:**

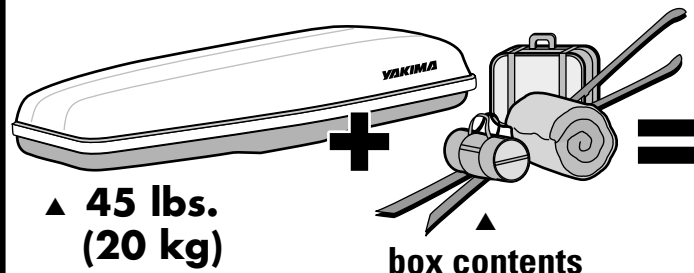

▲ 45 lbs.
(20 kg)

▲ box contents

contenu de la caisse
contenido de la caja

**DO NOT EXCEED
YOUR RACK'S weight limit!**
Check your owner's manual.

**NE PAS DÉPASSER
LA CHARGE ADMISSIBLE
SUR le porte-bagages!**
Consulter le manuel du véhicule.

**¡NO EXCEDA EL LÍMITE
de peso de SU PARRILLA!**
Búsquelo en el manual del propietario.

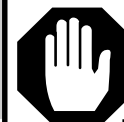

**DO NOT EXCEED
BOX CONTENT
WEIGHT LIMIT:
110 LBS. (50 KG)**

**LA CAISSE NE DOIT PAS
CONTENIR PLUS DE
50 KG (110 LB)**

**NO EXCEDA EL LÍMITE
DE PESO DEL CONTENIDO
DE LA CAJA:
110 LBS. (50 KG)**



**DISTRIBUTE YOUR
LOAD EVENLY.**

**RÉPARTIR LA
CHARGE
UNIFORMÉMENT**

**DISTRIBUYA LA
CARGA
PAREJAMENTE**

1 MEASURE THE DISTANCE BETWEEN THE CROSSBARS ON YOUR RACKS.

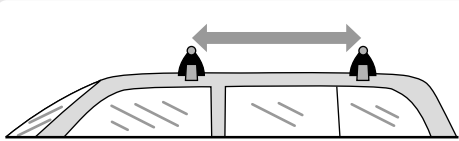

FOR BARS THAT CAN'T MOVE: (INCLUDING Q TOWERS)

Measure from bar to bar to determine which sets of holes your box will use.



Q TOWER NOTE:
NEVER REPOSITION THE TOWERS!

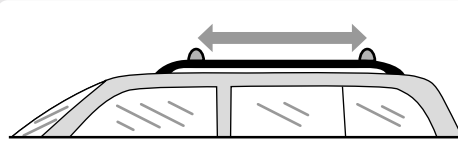

FOR BARS THAT MOVE OR SLIDE:

Bars should be positioned at 32" or 34" apart.



TIGHTEN YOUR CROSSBARS IF YOU LOOSENED THEM.

2 DO NOT LOAD THE BOX ONTO THE CAR YET.

Select the set of holes at the rear of the box which matches your crossbar measurement.

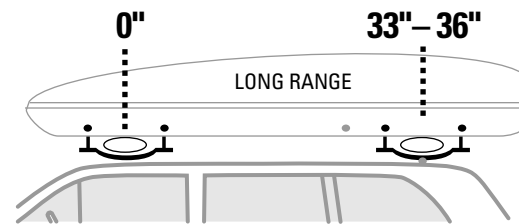
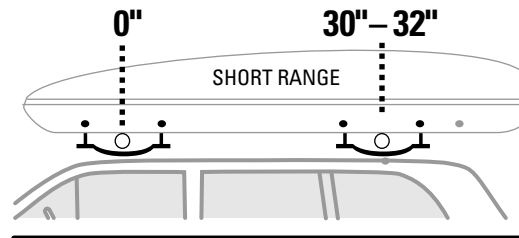

Do not drill additional holes.

3 INSIDE THE BOX:

Push plugs into unused holes.

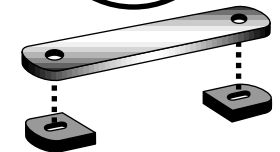
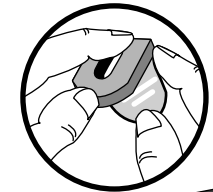
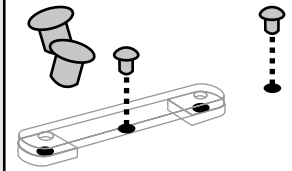

Attach adhesive pads to metallic plates.

4 ON THE OUTSIDE OF THE BOX:

- **CARRIAGE BOLT:** Insert through curved bracket, then through large plate.

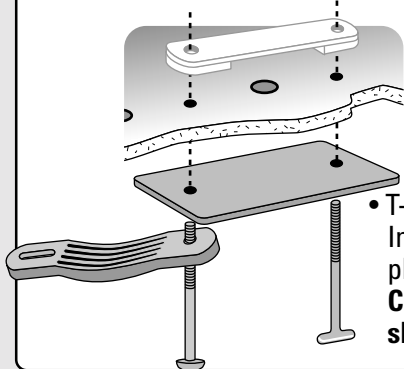

- **T-BOLT:** Insert through large plate only. Curved bracket should swing freely.

5 INSIDE OF BOX:

Set metallic plate onto bolts.

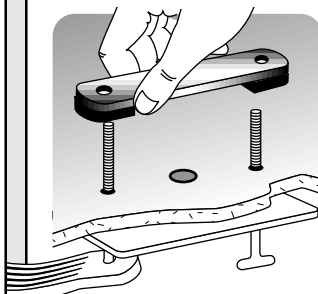

6 ATTACH KNOBS:

Engage the threads of the bolts with one slight turn—no more.

The knobs must be very loose.

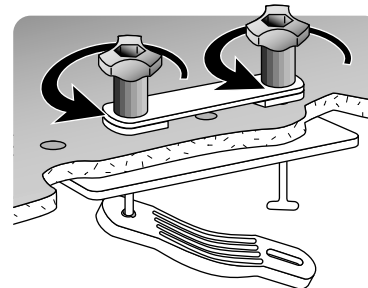

7 LOAD BOX ONTO RACKS.

Curved brackets should swing freely.

Be sure the brackets are not interfering when box is positioned on the bars.

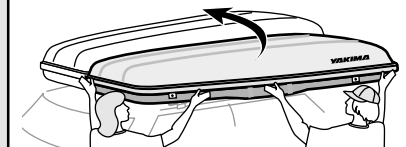

A friend could help with this part.

8 SECURE THE BOX TO THE BARS:

Swing brackets into position under bars.

Attach brackets to T-bolts.

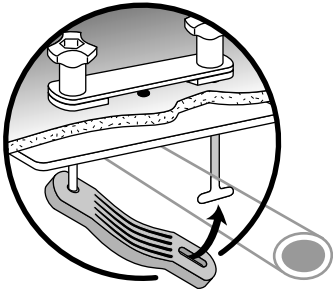

LOCK T-BOLTS:

T-bolt is locked when "T" is parallel to the crossbars.

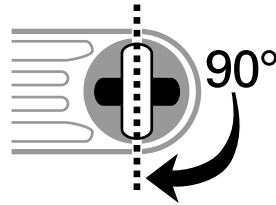

9 TIGHTEN THE KNOBS.

Tighten the knobs until the box cannot slide on bars.

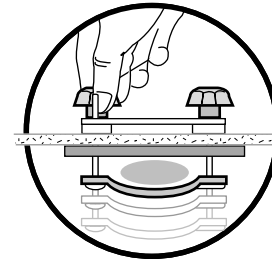

DO NOT overtighten!

REMEMBER...

NEVER REPOSITION YOUR YAKIMA Q TOWERS!



10 TO CLOSE YOUR BOX:

Grab the lid strap and pull the lid down until you can reach it with your hands.

The lid strap should be placed inside of the box.



BOTH LATCHES MUST PRODUCE AN AUDIBLE "CLICK" BEFORE THE BOX LID IS SECURE.

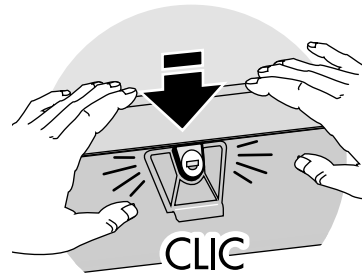

11 SAFETY CHECK:

✓ CHECK LATCHES

Push up on the lid.

CAUTION: Overstuffing the box will prevent a secure closure.

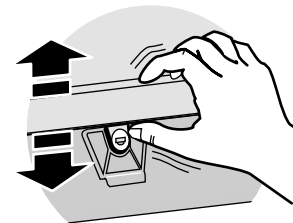

✓ CHECK INSTALLATION:

Make sure installation is secure by tugging at box.

The box should NOT SLIDE on the bars.

Open the box and tighten knobs if necessary.

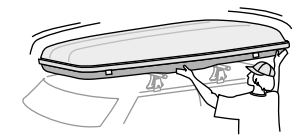

12 INSTALL OPTIONAL LOCKS:

If you have purchased the SKS® Lock Cores, install them now. Follow the instructions that came with the Lock Cores.

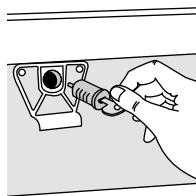

IF YOUR VEHICLE HAS A REAR HATCH:

On some vehicles, hatch interference is unavoidable.

Use caution when opening your hatch.

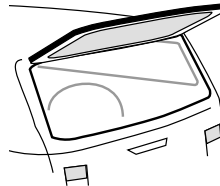

TO REMOVE THE BOX, DO NOT DISASSEMBLE THE HARDWARE.

- Loosen the knobs until barely attached.
- Unlock the T-bolts and let curved brackets swing freely.
- Remove box.

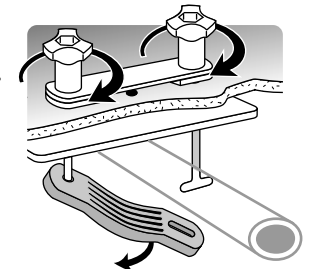

PERIODICALLY CHECK THE KNOBS INSIDE THE BOX AND TIGHTEN IF NECESSARY.

1 MESURER LA DISTANCE ENTRE LES BARRES TRANSVERSALES DE VOTRE PORTE-BAGAGES (FR)

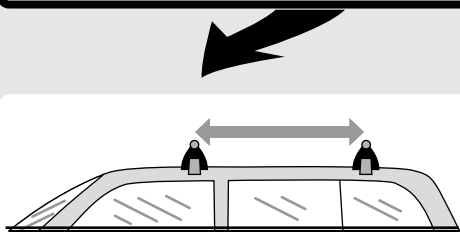

POUR LES BARRES FIXES: (Y COMPRIS LES PIEDS Q)

Mesurer la distance entre les barres pour déterminer quels trous utiliser.



**REMARQUE POUR LES PIEDS Q:
NE JAMAIS DÉPLACER
LES PIEDS**

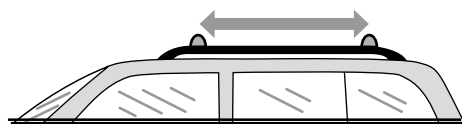

POUR LES BARRES QUI SE DÉPLACENT OU QUI COULISSENT:

Placer les barres entre 813 et 864 mm l'une de l'autre (entre 32 et 34 pouces).



**NE PAS OUBLIER DE
RESSERRER LES BARRES SI
ON LES A DESSERRÉES.**

2 NE PAS PLACER LA CAISSE SUR LA VOITURE TOUT DE SUITE.

Choisir les trous à l'arrière de la caisse correspondant à la distance entre les barres.

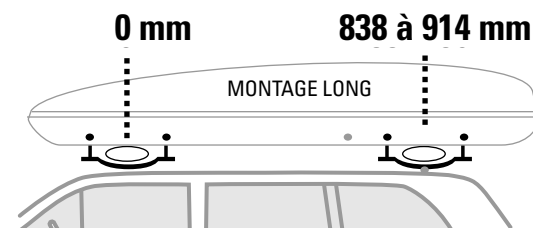
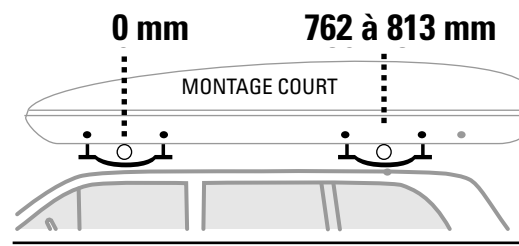

Ne pas percer de trous supplémentaires.

3 À L'INTÉRIEUR DE LA CAISSE:

Enfoncer des bouchons dans les trous qui ne serviront pas.

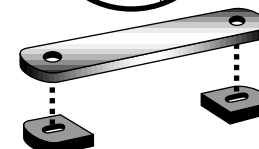
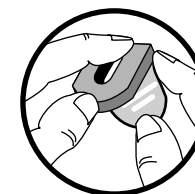
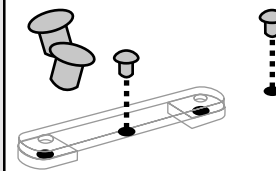

Coller les rondelles élastiques sur les plaquettes métallique.

4 À L'EXTÉRIEUR DE LA CAISSE:

- **BOULON À TÊTE BOMBÉE:**
Le glisser dans l'étrier, puis à travers la plaque.

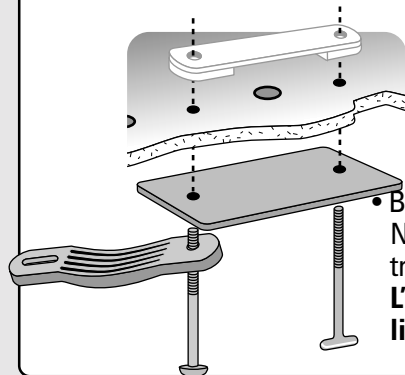

- **BOULON À TÊTE EN T:**
Ne le glisser qu'à travers la plaque
L'étrier doit tourner librement.

5 À L'INTÉRIEUR DE LA CAISSE:

Enfiler la plaquette métallique sur les boulons.

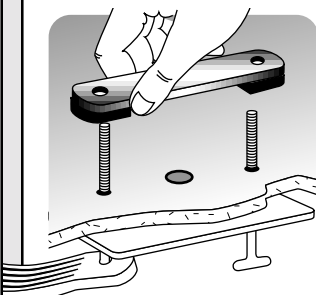

6 POSER LES ÉCROUS:

Engager les écrous sur le bout des boulons, d'un tour, sans plus.
Les écrous doivent laisser beaucoup de jeu aux boulons.

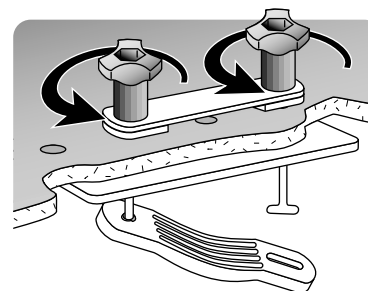

7 POSER LA CAISSE SUR LE PORTE-BAGAGES:

Les étriers doivent avoir beaucoup de jeu.
Attention de ne pas les coincer.

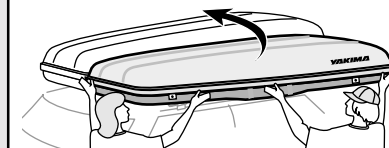

Cette opération est plus facile à deux personnes.

8 FIXER LA CAISSE AUX BARRES:

Amener les étriers en place sous les barres.

Enfiler les boulons à tête en T dans les étriers.

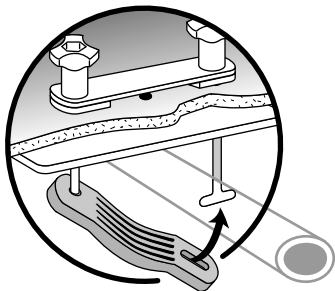

VERROUILLER LES BOULONS À TÊTE EN T:

Le boulon à tête en T est verrouillé quand sa tête est parallèle à la barre.

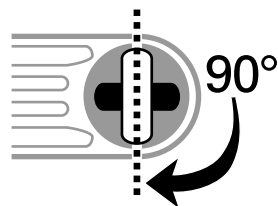

9 SERRER LES ÉCROUS:

Serrer les écrous jusqu'à ce que la caisse ne glisse plus sur les barres.

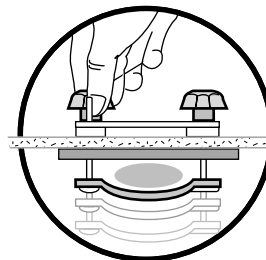

NE PAS trop serrer.

RAPPEL...

NE JAMAIS DÉPLACER LES PIEDS Q YAKIMA!

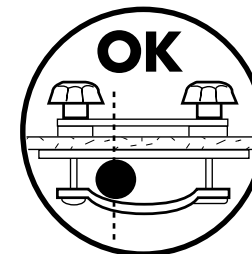

10 POUR FERMER LA CAISSE:

Abaissier le couvercle à l'aide de la sangle jusqu'à pouvoir le rabattre avec la main.



Ranger la sangle dans la caisse.



LES DEUX FERMOIRS doivent produire un «CLIC» sonore pour que le couvercle soit verrouillé.

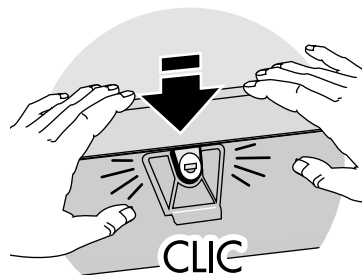

11 INSPECTION FINALE:

✓ VÉRIFIER LES FERMOIRS

Essayer de soulever le couvercle.

ATTENTION: Si la caisse est trop remplie, elle fermera mal.

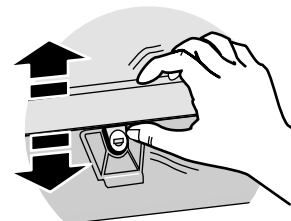

✓ VÉRIFIER LE MONTAGE:

Vérifier la solidité du montage en essayant de bouger la caisse.

La caisse ne doit PAS GLISSER sur les barres.

Au besoin, ouvrir la caisse et serrer les écrous.

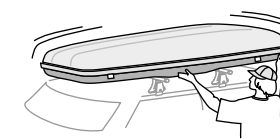

12 POSE DES SERRURES (EN OPTION):

Si vous avez acheté des serrures SKS LockCore, les poser maintenant en suivant les instructions qui les accompagnent.

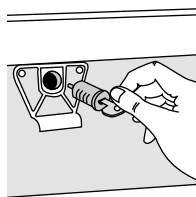

SI LE VÉHICULE EST DOTÉ D'UN HAYON:

Sur certain véhicules, le hayon risque de toucher à la caisse quand il est relevé.

Ouvrir le hayon avec soin.

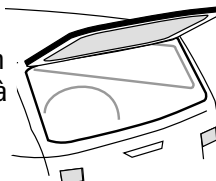

POUR ENLEVER LA CAISSE, NE PAS DÉMONTER LA QUINCAILLERIE.

- Desserrer les écrous au maximum, mais sans les enlever.
- Décrocher les boulons à tête en T et laisser les étriers pendre librement.
- Enlever la caisse.

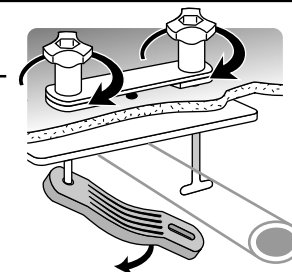

VÉRIFIER DE TEMPS À AUTRE LES ÉCROUS À L'INTÉRIEUR DE LA BOÎTE ET LES RESSERRER AU BESOIN.

1 MIDA LA DISTANCIA ENTRE LOS TRAVESAÑOS DE LA PARRILLA.

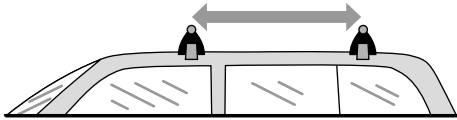

PARA TRAVESAÑOS QUE NO PUEDEN MOVERSE:

(INCLUYENDO SOPORTES Q-TOWERS)

Mida la distancia entre los travesaños para determinar qué juego de agujeros utilizará su caja.



NOTA PARA Q-TOWER:
¡NUNCA CAMBIE DE LUGAR LOS SOPORTES!

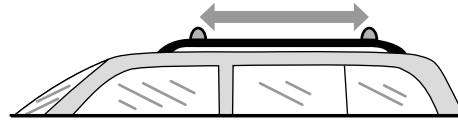

PARA TRAVESAÑOS QUE SE MUEVEN O DESLIZAN:

La separación entre travesaños debe ser de 32" (81 cm) o 34" (86 cm).



¡AJUSTE LOS TRAVESAÑOS SI SE HAN AFLOJADO!

2 NO COLOQUE LA CAJA SOBRE EL VEHÍCULO TODAVÍA.

Seleccione el conjunto de agujeros posterior de la caja que corresponda a la distancia entre travesaños.

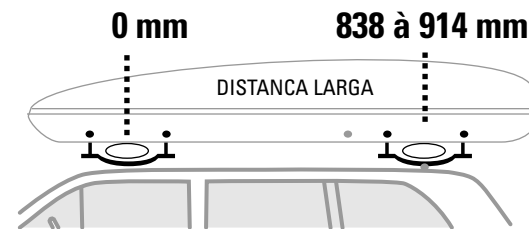
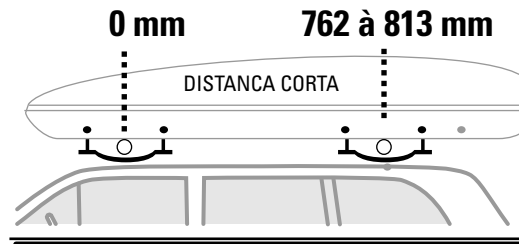

No perforo más agujeros.

3 DENTRO DE LA CAJA:

Coloque los tacos en los agujeros que no utilice.

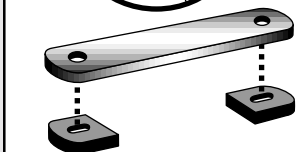
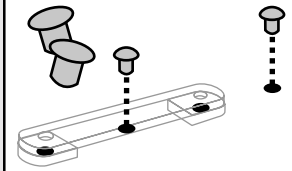

Coloque las almohadillas adhesivas en las placas metálica

4 FUERA DE LA CAJA:

- **TORNILLO COMÚN:** Insértelo a través de la pieza curva y de la placa grande.

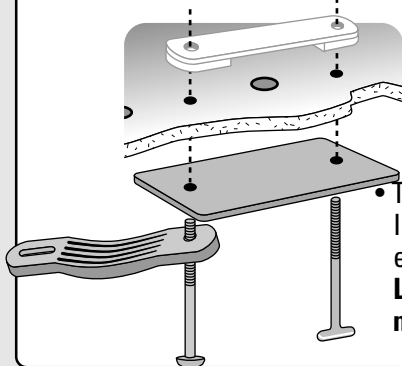

• **TORNILLO-T:** Insértelo solamente en la placa grande. La pieza curva debe moverse libremente.

5 DENTRO DE LA CAJA:

Coloque la placa metálica en los tornillos.

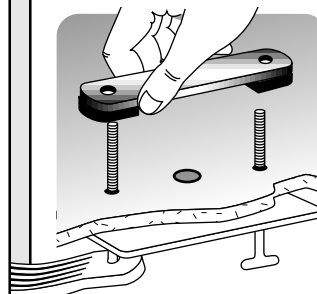

6 COLOQUE LAS PERILLAS:

Déles solo una ligera vuelta en los tornillos — no más.

Las perillas deben estar muy flojas.

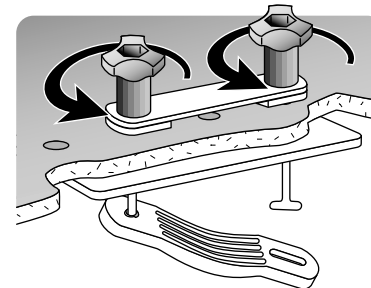

7 COLOQUE LA CAJA EN LA PARRILLA.

Las piezas curvas deben moverse libremente cuando cargue la caja.

Asegúrese de que no interfieren.

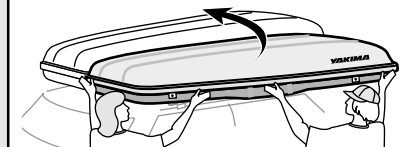

Un amigo podría ayudar aquí.

8 ASEGURE LA CAJA A LOS TRAVESAÑOS:

Coloque las piezas curvas bajo los travesaños y en los tornillos T.

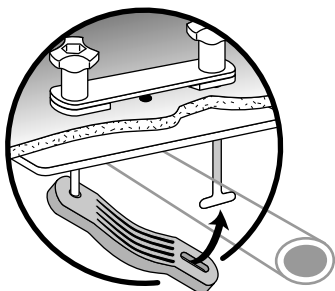

AJUSTE LOS TORNILLOS-T:

El tornillo queda ajustado cuando la "T" está paralela al travesaño.

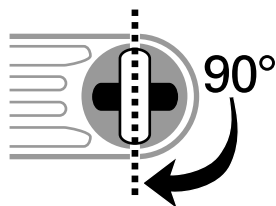

9 AJUSTE LAS PERILLAS:

Ajuste las perillas hasta que la caja no pueda deslizarse sobre los travesaños.

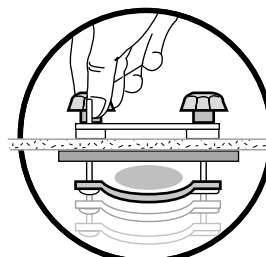

¡NO ajuste de más!

RECUERDE...

¡NUNCA CAMBIE DE POSICIÓN LOS SOPORTES Q TOWERS YAKIMA!

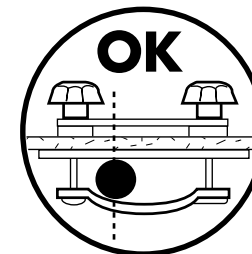

10 PARA CERRAR LA CAJA:

Agarre la cinta de la tapa y tire hacia abajo hasta que pueda alcanzar la tapa con las manos.



La cinta debe colocarse dentro de la caja.



AMBOS CIERRES deben hacer un "CLICK" audible para que la tapa quede asegurada.

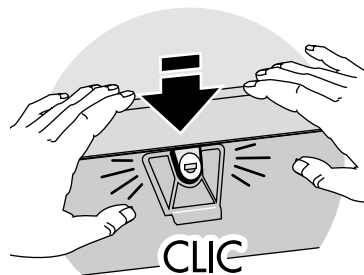

11 PRUEBA DE SEGURIDAD:

✓ VERIFIQUE LOS CIERRES

Trate de levantar la tapa. ATENCIÓN: Si la caja está demasiado llena el cierre puede ser inseguro.

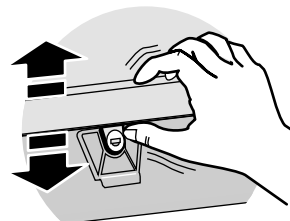

✓ VERIFIQUE LA INSTALACIÓN:

Asegúrese de que la instalación está firme sacudiendo la caja.

La caja NO DEBE deslizarse sobre los travesaños.

Abra la caja y ajuste las perillas si es necesario.

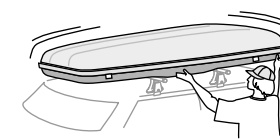

12 INSTALE CERROJOS OPCIONALES:

Si ha comprado los cerrojos SKS® Lock Cores, instélos ahora. Siga las instrucciones que vienen con ellos.

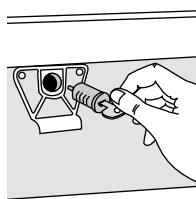

SI EL VEHÍCULO TIENE SEMIPUERTA TRASERA:

En algunos vehículos es inevitable la interferencia de la semipuerta.

Abra la semipuerta con cautela.

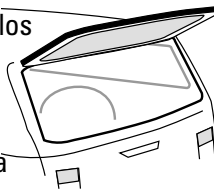

PARA QUITAR LA CAJA NO DESARME LAS PIEZAS.

- Afloje las perillas lo más posible.
- Afloje los tornillos T y deje que las piezas curvas se muevan libremente.
- Quite la caja.

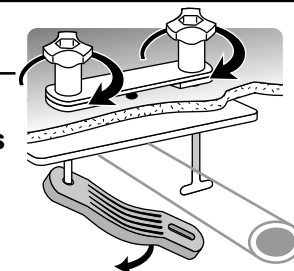

PERIÓDICAMENTE VERIFIQUE LAS PERILLAS DENTRO DE LA CAJA Y AJÚSTELAS SI ES NECESARIO.