

MINIMUM CROSSBAR SPREAD 24" (61CM)

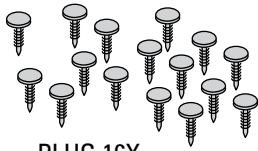

PLUG 16X

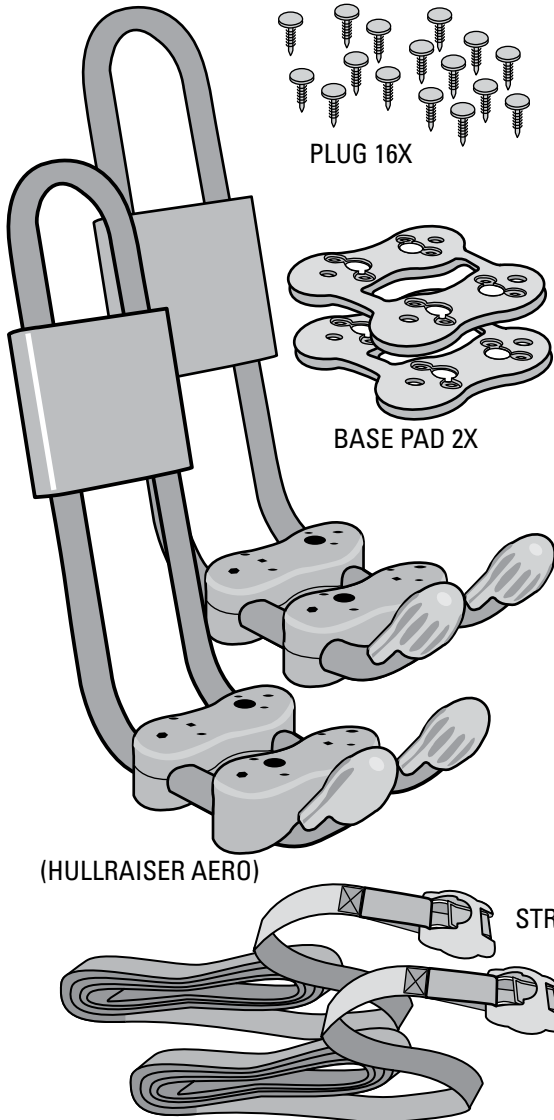
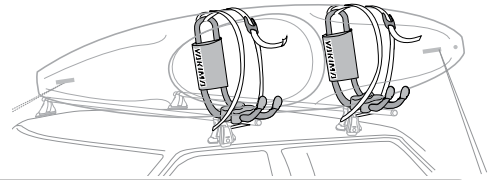
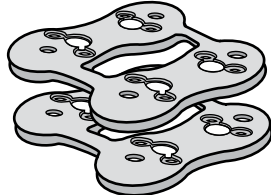

BASE PAD 2X

(HULLRAISER AERO)

STRAP 2X

**FITS ROUND, SQUARE,
AND FACTORY-INSTALLED
AERO BARS:**



To verify compatibility,
go online to www.yakima.com or
call (888) 925-4621

KNOB 4X



BRACKET 2X

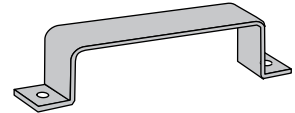

BAIL 2X



CARRIAGE BOLT 2X

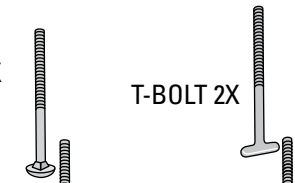

T-BOLT 2X

LONG CARRIAGE BOLT 2X

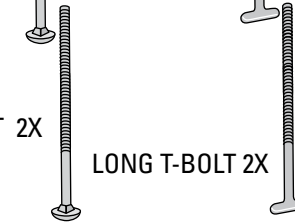

LONG T-BOLT 2X

**BOW STERN
TIE DOWN**

Buckle 2X

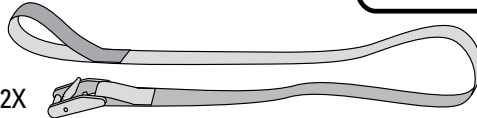

Plastic Tube 2X

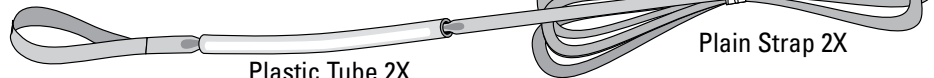

Plain Strap 2X

Steel Hook 2X



IMPORTANT WARNING

IT IS CRITICAL THAT ALL YAKIMA RACKS AND ACCESSORIES BE PROPERLY AND SECURELY ATTACHED TO YOUR VEHICLE. IMPROPER ATTACHMENT COULD RESULT IN AN AUTOMOBILE ACCIDENT, AND COULD CAUSE SERIOUS BODILY INJURY OR DEATH TO YOU OR TO OTHERS. YOU ARE RESPONSIBLE FOR SECURING THE RACKS AND ACCESSORIES TO YOUR CAR, CHECKING THE ATTACHMENTS PRIOR TO USE, AND PERIODICALLY INSPECTING THE PRODUCTS FOR ADJUSTMENT, WEAR, AND DAMAGE. THEREFORE, YOU MUST READ AND UNDERSTAND ALL OF THE INSTRUCTIONS AND CAUTIONS SUPPLIED WITH YOUR YAKIMA PRODUCT PRIOR TO INSTALLATION OR USE. IF YOU DO NOT UNDERSTAND ALL OF THE INSTRUCTIONS AND CAUTIONS, OR IF YOU HAVE NO MECHANICAL EXPERIENCE AND ARE NOT THOROUGHLY FAMILIAR WITH THE INSTALLATION PROCEDURES, YOU SHOULD HAVE THE PRODUCT INSTALLED BY A PROFESSIONAL INSTALLER SUCH AS A QUALIFIED GARAGE OR AUTO BODY SHOP.

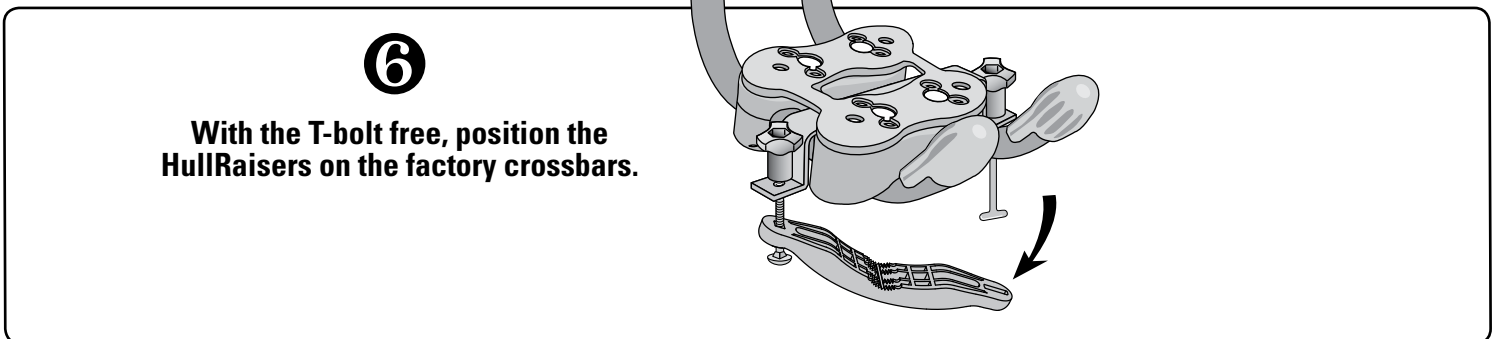
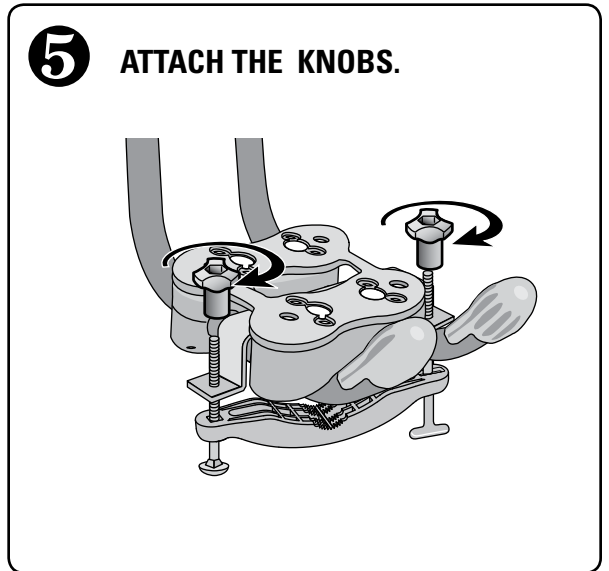
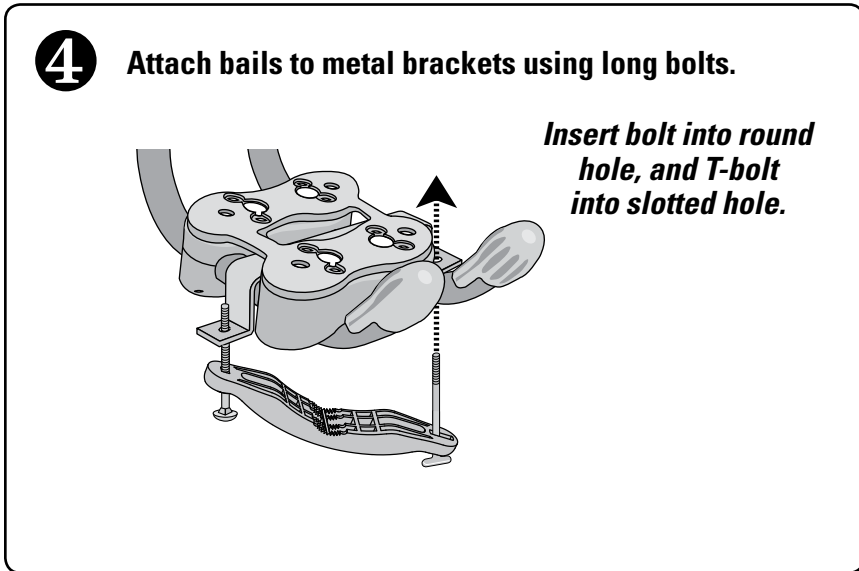
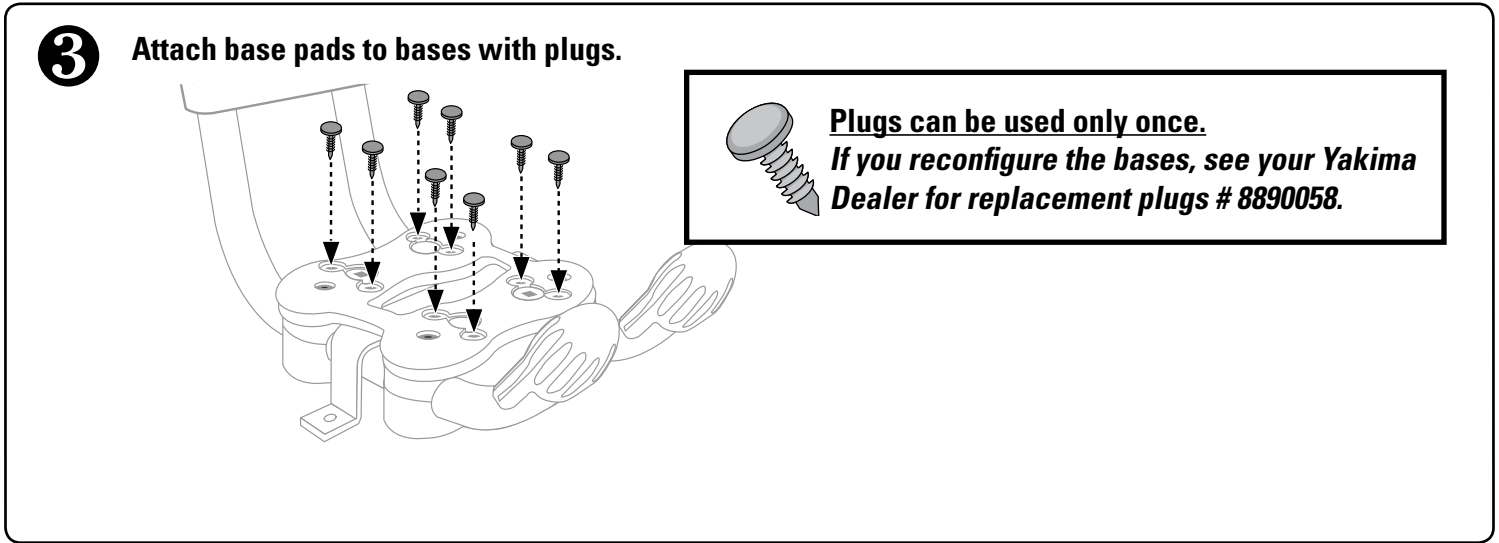
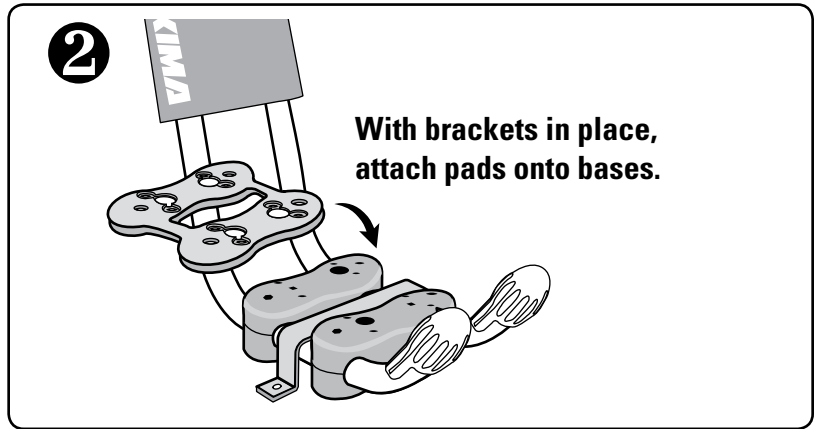
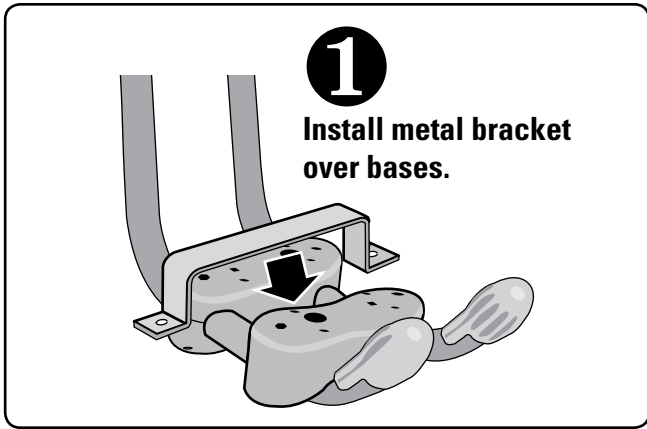

7 MAKE SURE THE CARRIERS SIT VERTICALLY ON THE BARS.

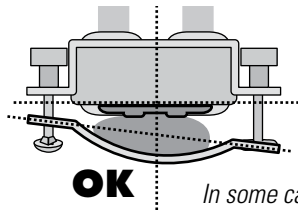
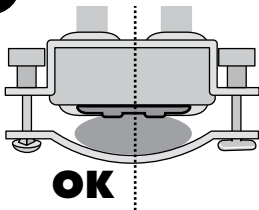

In some cases, the bracket and the bail may not be parallel.

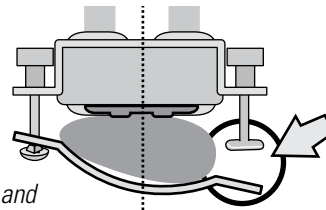

If the bolts seem too short, use the longer bolts included in this kit.

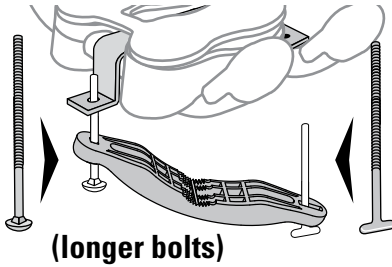

BOLTS MUST NOT EXTEND ABOVE THE KNOBS.

If bolts extend above the knob, you must use the shorter bolts.

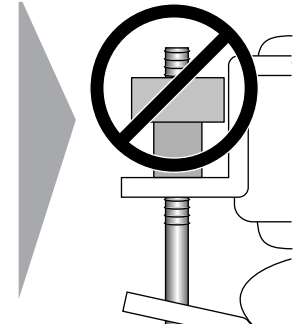

8

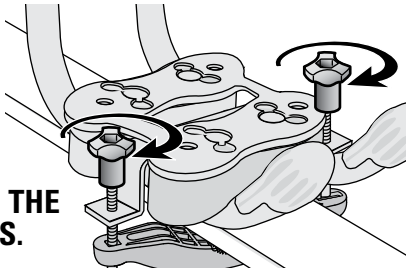

TIGHTEN THE KNOBS.

9

Adjust foam pads to support boat at contact points.

Note: Some lacquer hull finishes may stick to pads. Protect with soft cloth.

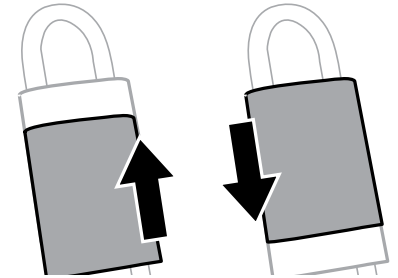

10 LOAD THE BOAT, AND TIE IT DOWN.

- Loop strap around hoop of HullRaiser.
- Bring straps up and over boat so that they hang in front of the boat.

- Slide buckle up so that it hangs at top edge of boat.
- Thread end of strap around tower or crossbar.

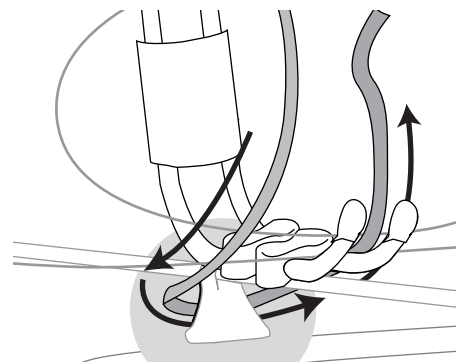
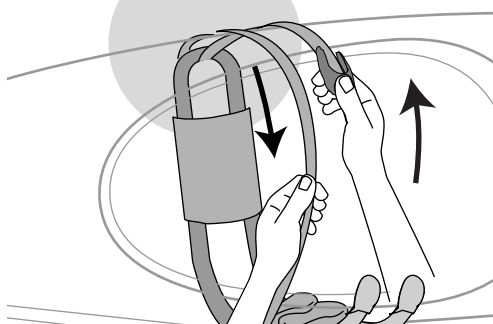

11

SECURE STRAPS.

Press open buckle and insert end of strap.

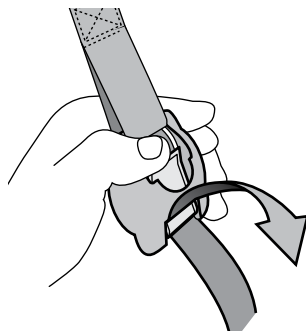

- To tighten straps, hold and pull.
- Secure the loose ends.

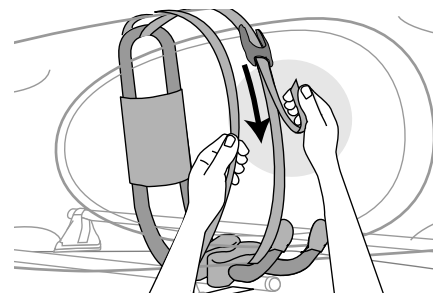

12 Attach buckle strap to bow and stern of boat.

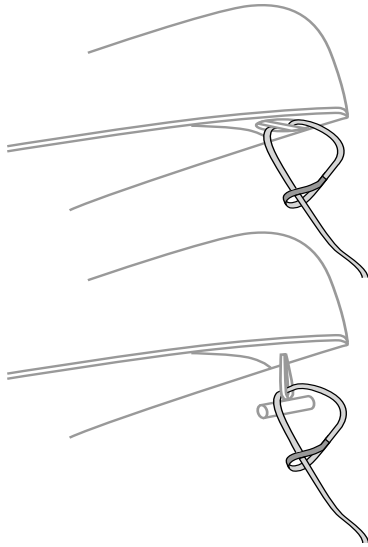

Attach strap to *grab handle* or *rescue bar* and pull tight.

13 Attach hook to plain strap loop.

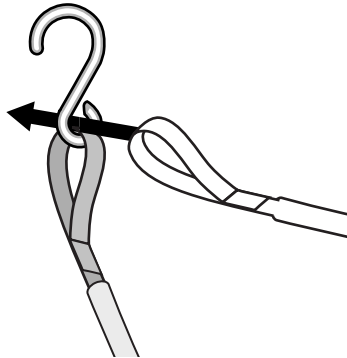

14 Hook the strap to a metal surface on the bumper, tow loop, or frame hole using hook.

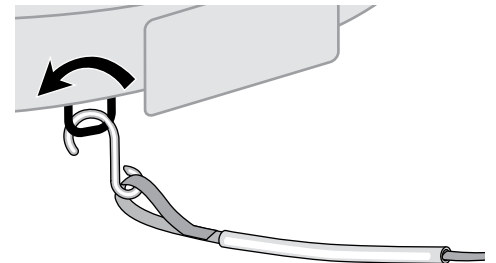

15 Slide plastic tube to protect vehicle at contact point.

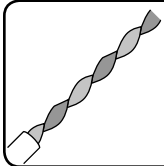

NOTE: Twisting the strap will help reduce wind vibration.

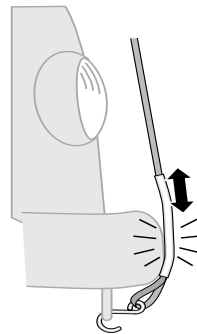

17 Adjust strap tension by pulling plain end.

- Apply even pressure to front and rear straps.
- Bind up and tie off any excess strap.

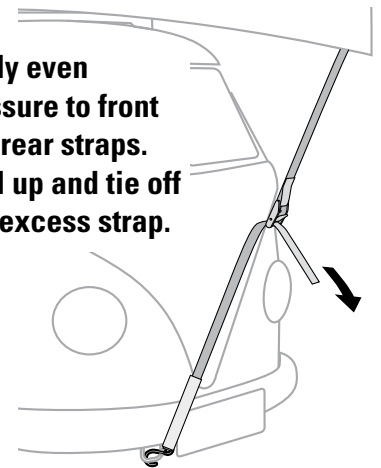

16 Insert end of plain strap into buckle.

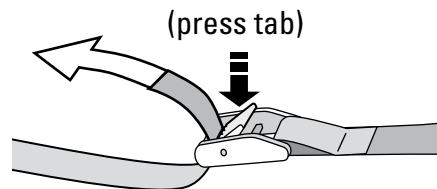

Failure to secure front and rear of long loads to ends of vehicle can result in property damage, personal injury, or death.



BEFORE DRIVING AWAY

- Test movement by rocking boat.
- Tighten again if loose.
- READ ALL CAUTIONS AND LIMITS ON NEXT PAGE.



Check straps periodically during travel and tighten if necessary. Replace any straps that are worn or frayed before using (see your Yakima dealer).

SEE YOUR ACCESSORY INSTRUCTIONS FOR IMPORTANT WARNINGS



WEIGHT LIMITS

Follow the YAKIMA Fit List for your rack's weight limit. Do not exceed the weight limit of your vehicle's racks.

Maximum weight is 165 lbs. (75 kg) unless otherwise noted.

IF YOU REMOVE YOUR CARRIER, FOLLOW INSTRUCTIONS TO INSTALL AGAIN.

Follow safety checks in accessory instructions before every installation.

REAR HATCH

Some longer loads may prevent the rear hatch from fully opening.

ALWAYS USE CAUTION WHEN OPENING YOUR HATCH.

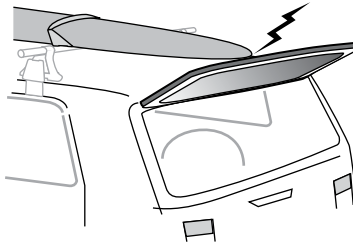

ANTENNA

Antenna on the roof may need to be removed to prevent interference with long loads.

WARNING: BE SURE ALL HARDWARE IS SECURED ACCORDING TO INSTRUCTIONS. ATTACHMENT HARDWARE CAN LOOSEN OVER TIME. CHECK BEFORE EACH USE, AND TIGHTEN IF NECESSARY.

MAINTENANCE: Use non-water soluble lubricant on screws. Use a soft cloth with water and mild detergent to clean plastic parts.

REMOVE ACCESSORY BEFORE ENTERING AN AUTOMATIC CAR WASH.

**TECHNICAL ASSISTANCE
OR REPLACEMENT PARTS**
Contact your dealer or call
(888)925-4621
Monday through Friday,
7:00 AM to 5:00 PM, PST



This product is covered by YAKIMA's "Love It Till You Leave It" Limited Lifetime Warranty

To obtain a copy of this warranty, go online to www.yakima.com or email us at yakwarranty@yakima.com or call (888) 925-4621

KEEP THESE INSTRUCTIONS!

LA DISTANCE ENTRE LES BARRES
TRANSVERSALES DOIT ÊTRE AU MOINS
DE 24 POUCES (61 CM).

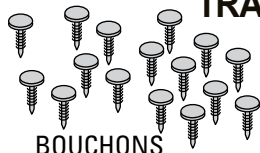
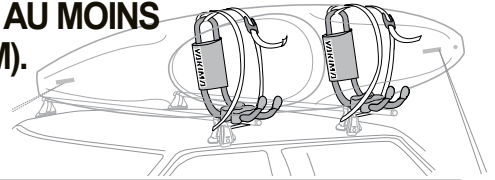

BOUCHONS
16X

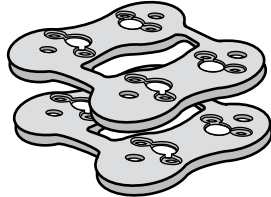

GARNITURES
DE FOND 2X

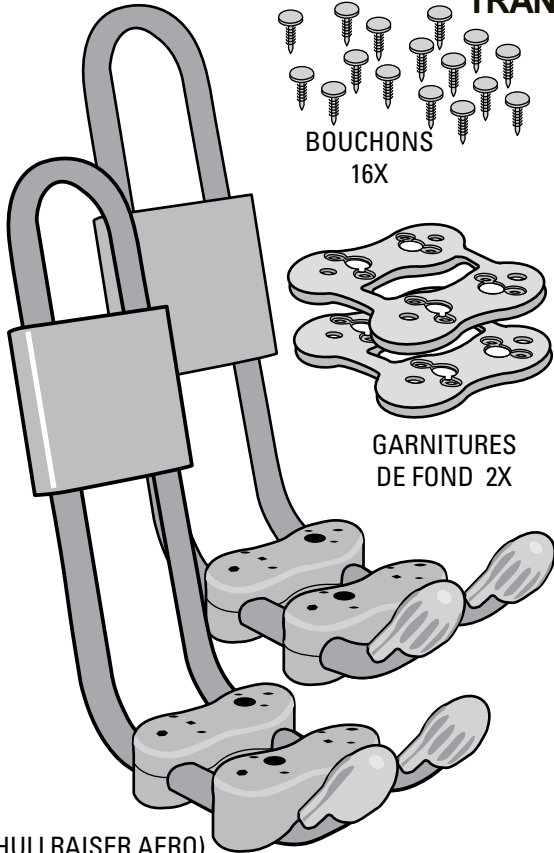

(HULLRAISER AERO)

SANGLES
2X

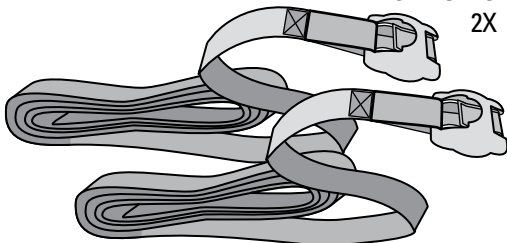

**BARRES RONDÉS ET
BARRES CARRÉES, BARRES
AERO D'ORIGINE:**
Pour vérifier la compatibilité,
consulter le site
www.yakima.com ou appeler
au (888) 925-4621.



BOUTONS 4X

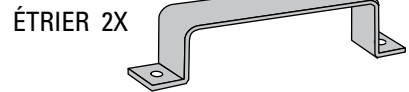

ÉTRIER 2X

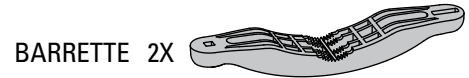

BARRETTE 2X

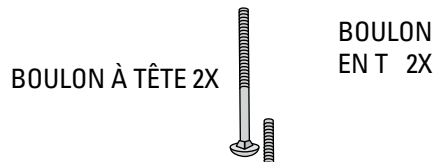

BOULON À TÊTE 2X

BOULON
ENT 2X



BOULON À TÊTE BOMBÉE 2X

LONG BOULON
ENT 2X

**ATTACHE
DE PROUE/
DE POUPE**



BOUCLE
2X

MANCHON EN PLASTIQUE 2X

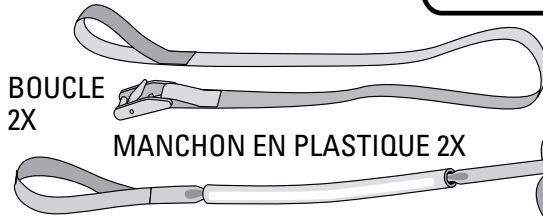

SANGLE SANS BOUCLE 2X

CROCHET EN
ACIER 2X

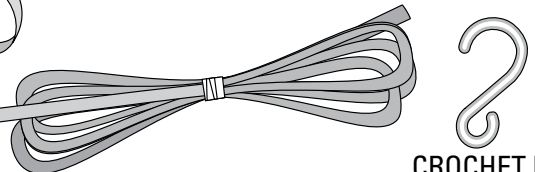

AVERTISSEMENT IMPORTANT

IL EST IMPÉRATIF QUE LES PORTE-BAGAGES ET LES ACCESSOIRES YAKIMA SOIENT CORRECTEMENT ET SOLIDEMENT FIXÉS AU VÉHICULE. UN MONTAGE MAL RÉALISÉ POURRAIT PROVOQUER UN ACCIDENT D'AUTOMOBILE, QUI POURRAIT ENTRAÎNER DES BLESSURES GRAVES OU MÊME LA MORT, À VOUS OU À D'AUTRES PERSONNES. VOUS ÊTES RESPONSABLE DE L'INSTALLATION DU PORTE-BAGAGES ET DES ACCESSOIRES SUR VOTRE VÉHICULE, D'EN VÉRIFIER LA SOLIDITÉ AVANT DE PRENDRE LA ROUTE ET DE LES INSPECTER RÉGULIÈREMENT POUR EN CONTRÔLER L'ÉTAT, L'AJUSTEMENT ET L'USURE. VOUS DEVEZ DONC LIRE ATTENTIVEMENT TOUTES LES INSTRUCTIONS ET TOUS LES AVERTISSEMENTS ACCOMPAGNANT VOTRE PRODUIT YAKIMA AVANT DE L'INSTALLER ET DE L'UTILISER. SI VOUS NE COMPRENEZ PAS TOUTES LES INSTRUCTIONS ET TOUS LES AVERTISSEMENTS, OU SI VOUS N'AVEZ PAS DE COMPÉTENCES EN MÉCANIQUE ET NE COMPRENEZ PAS PARFAITEMENT LA MÉTHODE DE MONTAGE, VOUS DEVRIEZ FAIRE INSTALLER LE PRODUIT PAR UN PROFESSIONNEL, COMME UN MÉCANICIEN OU UN CARROSSIER COMPÉTENT.

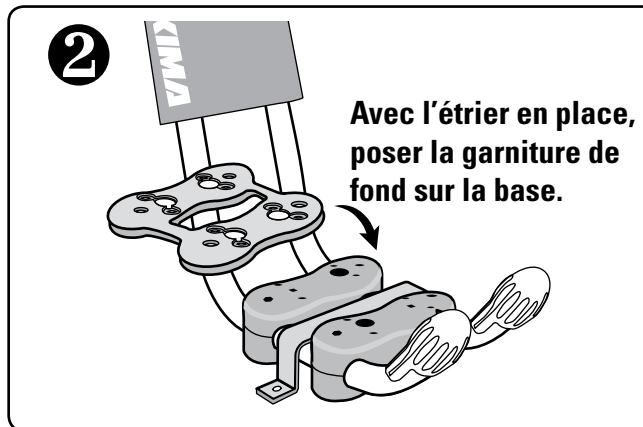
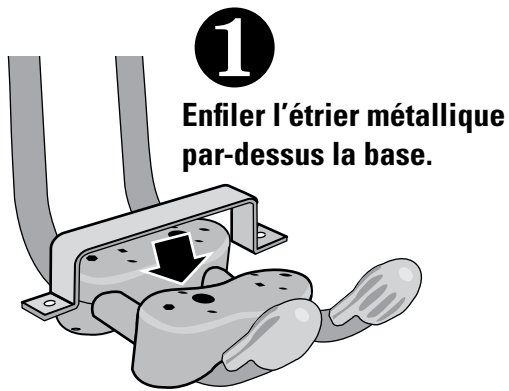

3 Fixer la garniture à la base avec les bouchons.

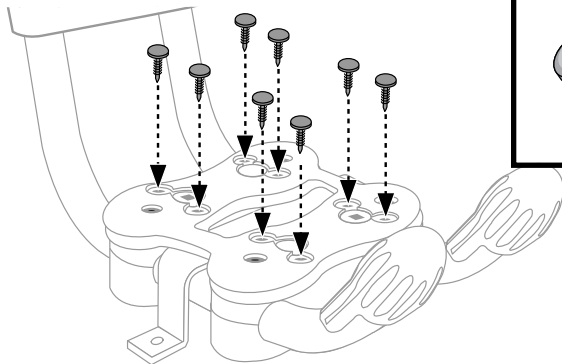

Les bouchons ne peuvent servir qu'une fois. Si l'on reconfigure les bases, se procurer auprès d'un dépositaire Yakima les bouchons de remplacement n° 8890058.

4 Enfiler les boulons à travers la barrette et l'étrier.

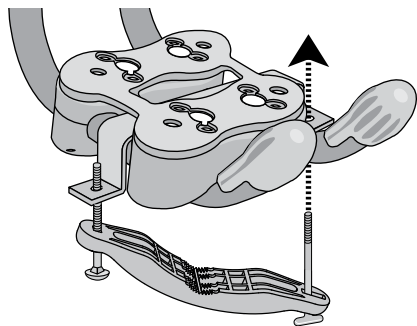

Enfiler le boulon à tête bombée dans le trou rond et le boulon en T dans le trou allongé.

5 POSER LES BOUTONS.

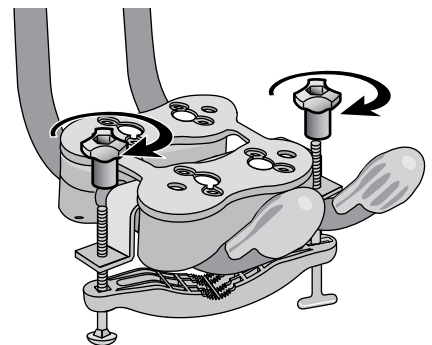

6

En conservant le boulon en T libre, positionner le porte-kayak sur la barre transversale d'origine.

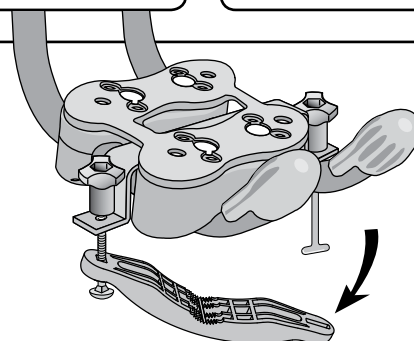

7 S'ASSURER QUE LE PORTE-KAYAK SOIT INSTALLÉ VERTICALEMENT SUR LA BARRE.

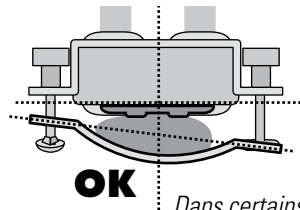
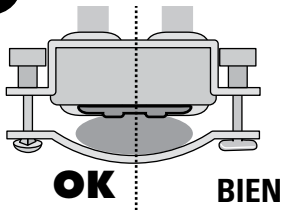

Dans certains cas, l'étrier et la barrette ne seront pas parallèles.

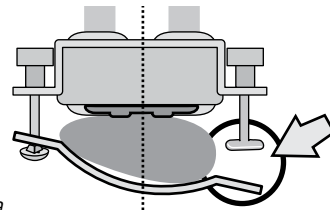

Si les boulons sont trop courts, employer les boulons longs compris dans la trousse.

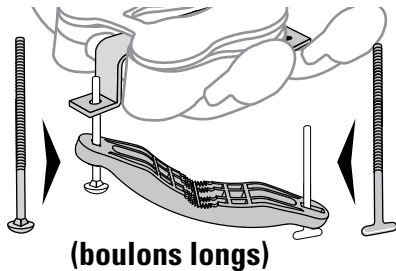

LES BOULONS NE DOIVENT PAS S'ÉTENDRE AU-DESSUS DES BOUTONS.

Si les boulons s'étendent au-dessus du bouton, vous devez utiliser les boulons plus courts.

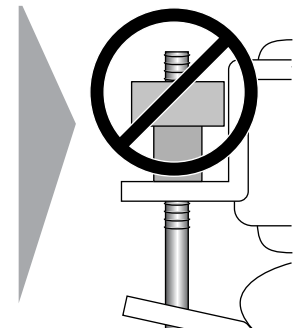

8

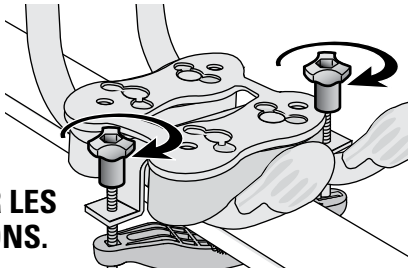

SERRER LES BOUTONS.

9

On peut faire coulisser les manchons vers le haut ou le bas, ou les décaler, pour soutenir l'embarcation aux points de contact.

Remarque : le fini laqué de certaines coques peut coller aux manchons. Intercaler un chiffon doux.

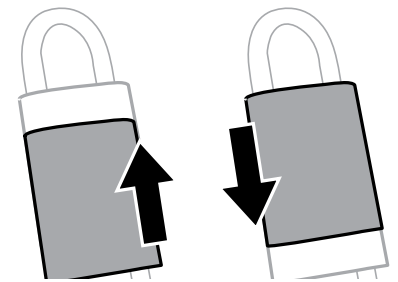

10 CHARGER L'EMBARCATION ET L'AMARRER.

- Passer la sangle dans l'arceau du porte-kayak HullRaiser.
- Ramener les deux bouts de la sangle par le dessus du kayak pour qu'ils pendent sur le devant.

- Tirer sur la sangle pour que la boucle se retrouve près du haut du kayak.
- Passer l'autre bout de la sangle derrière le pied ou la barre transversale.

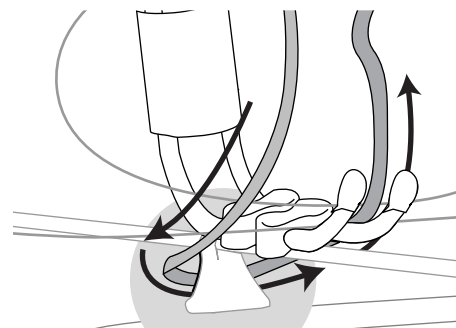
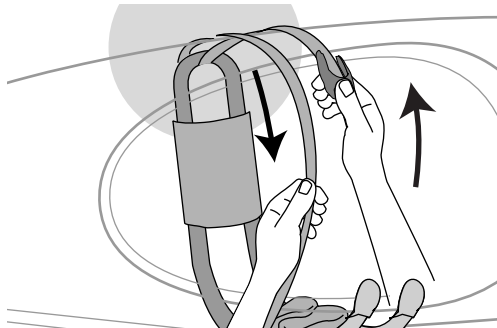

11 ATTACHER LES SANGLES

Ouvrir la boucle en appuyant et enfiler le bout de la sangle.

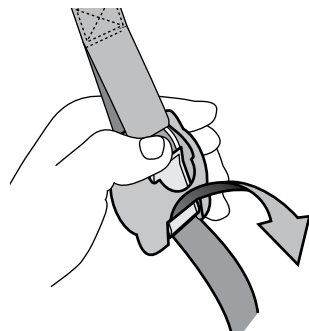

- Pour serrer la sangle, tirer vers le bas en retenant l'autre brin.
- Serrer les extrémités de la sangles.

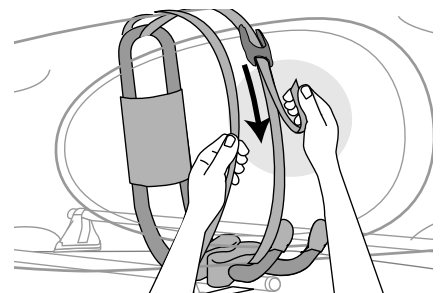

12 Attacher la sangle avec boucle à l'embarcation.

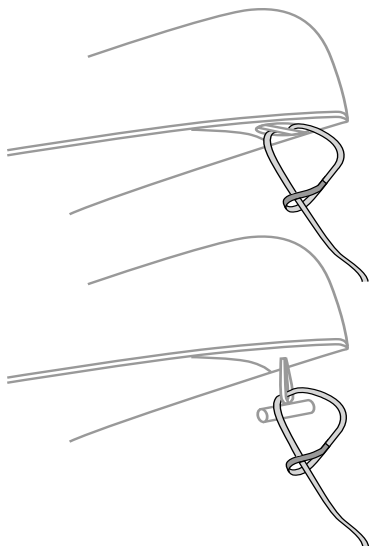

Fixer la sangle à la poignée ou à la barre de transport et bien serrer.

13 Fixer le crochet dans l'anneau de la sangle sans boucle.

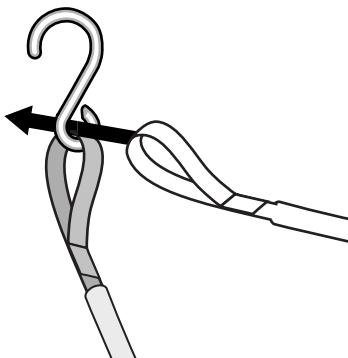

14 Accrocher la sangle à un rebord métallique du pare-chocs, à un anneau de remorquage ou dans un trou du châssis.

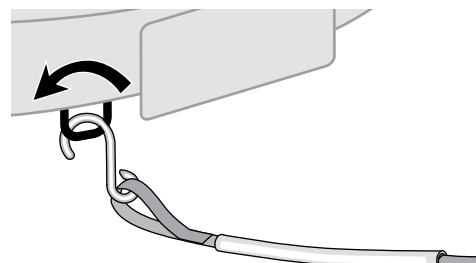

15 Faire coulisser le manchon en plastique pour protéger le véhicule au point de contact.

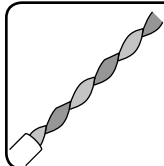

REMARQUE : si l'on donne plusieurs tours à la sangle elle vibrera moins dans le vent.

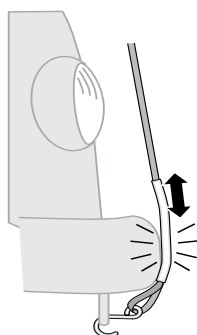

17 Régler la tension de la sangle en tirant sur le bout libre.

- Tendre également les sangles avant et arrière.
- Enrouler et attacher l'excédent des sangles.

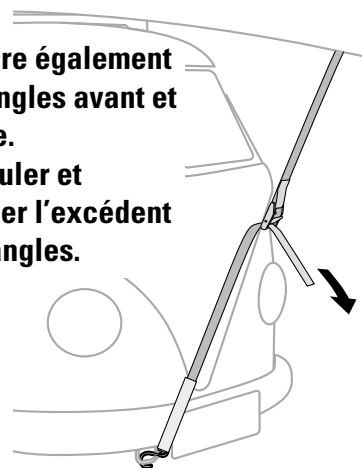

16 Enfiler le bout de la sangle sans boucle dans la boucle.

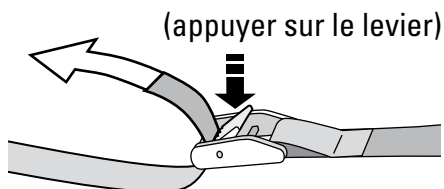

Toujours attacher le bout des charges longues à l'avant et à l'arrière du véhicule, sous peine de risquer de provoquer des dommages, des blessures ou même la mort.

AVANT DE PRENDRE LA ROUTE



- Vérifier la solidité du montage en balançant l'embarcation.
- Serrer les sangles ou les boulons un peu plus s'il y a du jeu.
- **LIRE TOUS LES AVERTISSEMENTS ET RESPECTER LES LIMITES FIGURANT À LA PAGE SUIVANTE.**



Vérifier les sangles régulièrement durant le trajet et les serrer au besoin. Si une sangle est usée ou effilochée, la remplacer (consulter le dépositaire Yakima).

LIRE LES AVERTISSEMENTS IMPORTANTS FIGURANT DANS LES INSTRUCTIONS ACCOMPAGNANT L'ACCESSOIRE



LIMITE DE CHARGEMENT

Consulter la liste de compatibilité YAKIMA ("Fit list") pour connaître la limite de chargement. Ne pas dépasser la limite de chargement fixée pour le porte-bagages.

La charge maximale est de 75 kg (165 lb) à moins d'indication contraire.

SI L'ON ENLÈVE LE PORTE-KAYAK, SUIVRE LES INSTRUCTIONS POUR LE REMETTRE EN PLACE.

Effectuer les vérifications de sécurité indiquées dans les instructions accompagnant l'accessoire lors de chaque remontage.

HAYON

Certaines charges longues pourraient empêcher d'ouvrir le hayon complètement.

OUVRIR LE HAYON AVEC PRUDENCE.

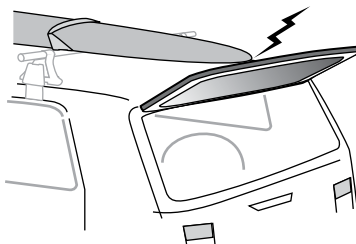

ANTENNE

Il faudra peut-être enlever l'antenne du toit si elle gêne les charges longues.

AVERTISSEMENT: S'ASSURER QUE LE MONTAGE EST SOLIDE ET CONFORME AUX INSTRUCTIONS. LES DISPOSITIFS DE FIXATION PEUVENT SE DESSERRER À LA LONGUE. LES INSPECTER AVANT CHAQUE UTILISATION ET LES RESSERRER AU BESOIN.

ENTRETIEN: Lubrifier les boulons avec un lubrifiant non soluble à l'eau. Nettoyer les pièces en plastique avec un chiffon, de l'eau et un savon doux.

ENLEVER L'ACCESSOIRE AVANT DE PASSER DANS UN LAVE-AUTO AUTOMATIQUE.

RENSEIGNEMENTS TECHNIQUES COMPLÉMENTAIRES OU DE PIÈCES DE RECHANGE: prière de contacter votre dépositaire ou appelez-nous au (888) 925-4621 du lundi au vendredi, entre 7 heures et 17 heures, heure du Pacifique.

Ce produit est couvert par YAKIMA Garantie à vie limitée «Tant que durera notre histoire d'amour»

Pour obtenir une copie de cette garantie, aller en ligne à www.yakima.com, ou nous envoie un e-mail à yakwarranty@yakima.com ou l'appel (888) 925-4621



CONSERVER CES INSTRUCTIONS!

SEPARACIÓN MÍNIMA ENTRE TRAVESAÑOS 24" (60 CM)

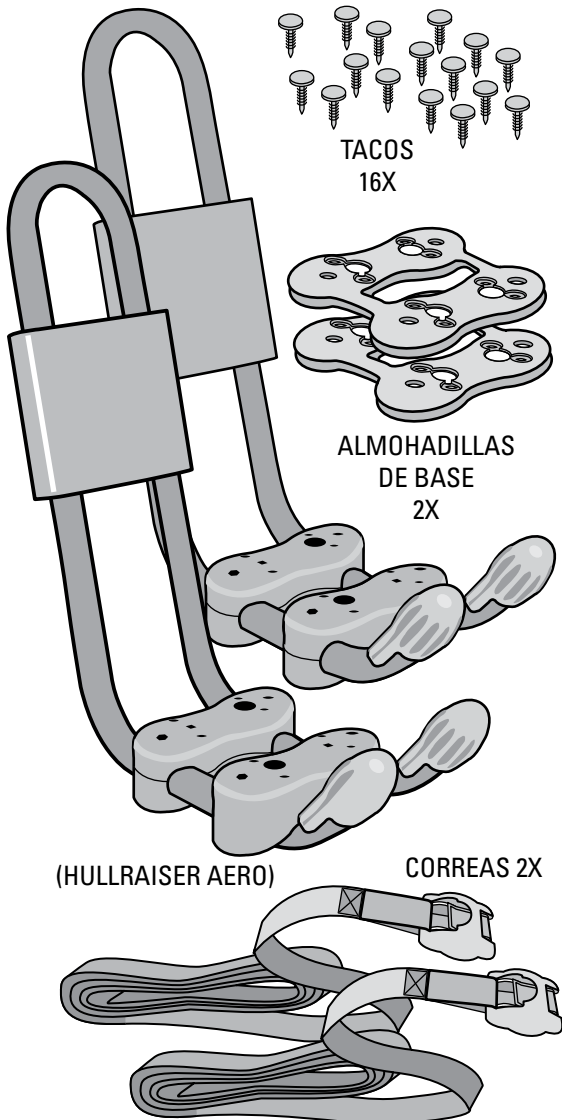
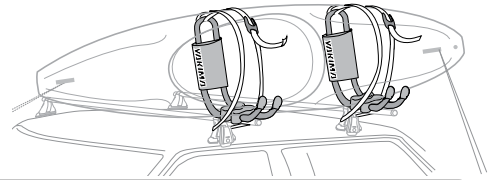

**BARRAS AÉREAS
INSTALADAS EN FÁBRICA:**
 Para verificar la compatibilidad,
 diríjase a www.yakima.com o
 llame al (888) 925-4621.

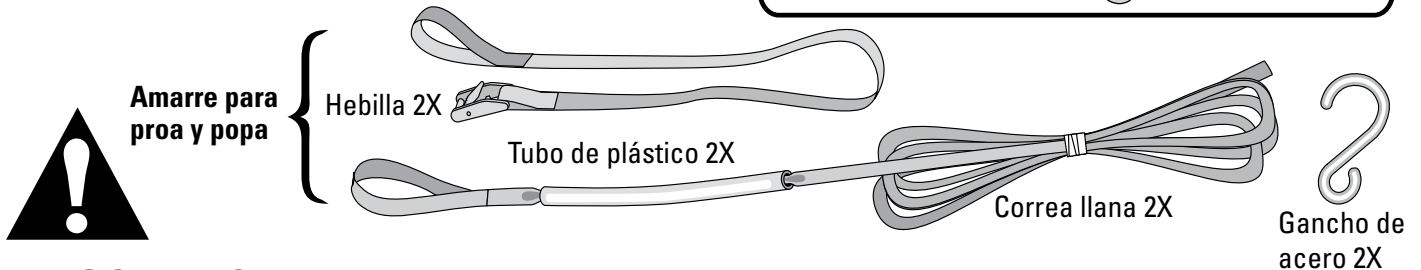
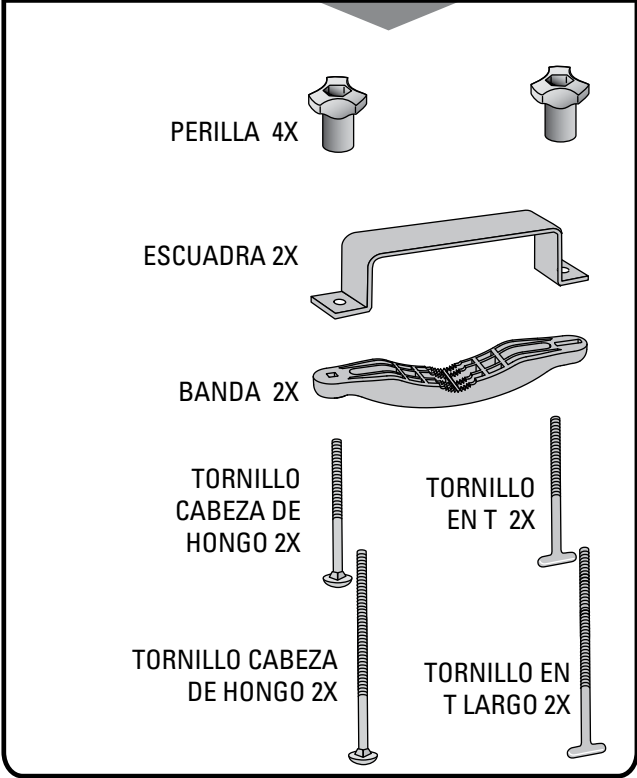

AVISO IMPORTANTE!

ES FUNDAMENTAL QUE TODAS LAS PARRILLAS Y ACCESORIOS YAKIMA ESTÉN BIEN COLOCADOS Y ASEGURADOS AL VEHÍCULO. UNA INSTALACIÓN DEFICIENTE PODRÍA RESULTAR EN ACCIDENTE AUTOMOVILÍSTICO Y PROVOCAR HERIDAS GRAVES O MUERTE A USTED O A TERCEROS. USTED ES RESPONSABLE DE ASEGURAR LAS PARRILLAS Y ACCESORIOS AL VEHÍCULO, VERIFICANDO UNIONES Y AMARRES ANTES DE USAR E INSPECCIONANDO EL AJUSTE DE LOS PRODUCTOS, SU DESGASTE Y POSIBLES DAÑOS. POR ELLO DEBE LEER Y COMPRENDER TODAS LAS INSTRUCCIONES Y ADVERTENCIAS QUE VIENEN CON LOS PRODUCTOS YAKIMA ANTES DE INSTALARLOS O USARLOS. SI NO ENTIENDE TODAS LAS INSTRUCCIONES Y ADVERTENCIAS, O NO TIENE EXPERIENCIA EN MECÁNICA O NO ESTÁ FAMILIARIZADO CON LOS PROCEDIMIENTOS DE INSTALACIÓN, HAGA INSTALAR EL PRODUCTO POR UN PROFESIONAL EN UN GARAGE CONOCIDO O EN UN TALLER DE CARROCERÍA.

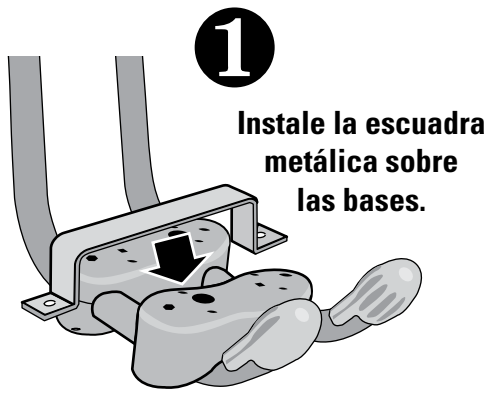

3 Fije las almohadillas con los tacos.

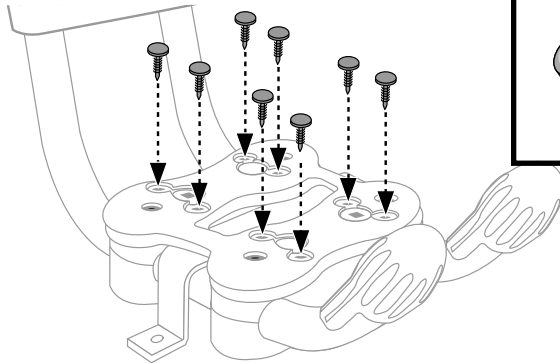

Los tacos pueden usarse solo una vez. Si vuelve a configurar las bases, pida tacos de replazo #8890058 a su concesionario Yakima.

4 Fije las bandas a las escuadras metálicas con tornillos largos.

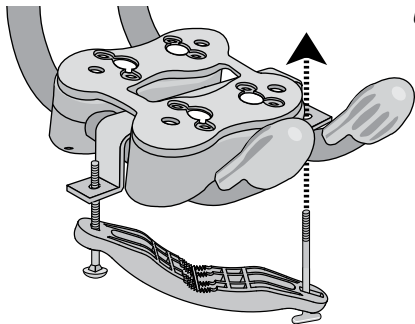

Inserte el tornillo en el agujero redondo y el tornillo en T en el alargado.

5 COLOQUE LAS PERILLAS.

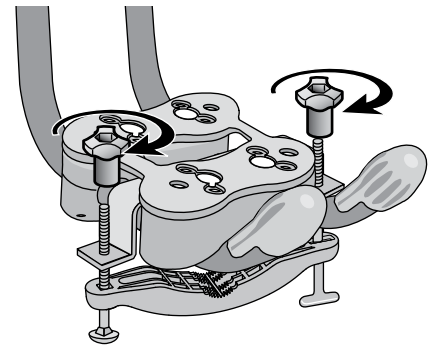

6

Liberando el tornillo en T, coloque los HullRaisers sobre los travesaños de fábrica.

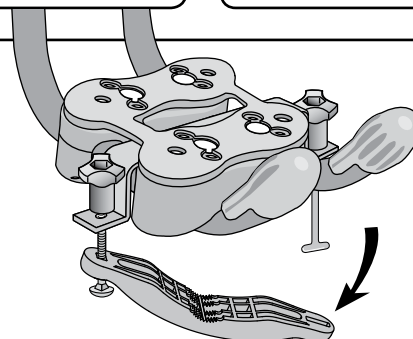

7 CERCÍOARSE DE QUE LOS ARCOS QUEDAN VERTICALES SOBRE LOS TRAVESAÑOS.

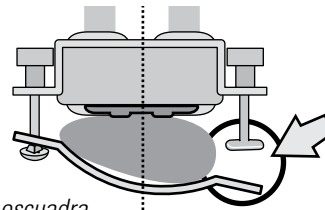
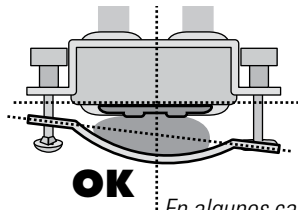
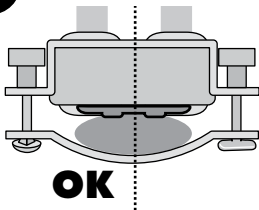

Si los tornillos parecen muy cortos, use los largos que vienen con el juego.

En algunos casos puede que la escuadra y la banda no queden paralelas.



(tornillos más largos)



CERROJOS NO DEBE EXTENDER ENCIMA DE LAS PERILLAS.

Si cerrojos extienden encima de la perilla, usted debe utilizar los cerrojos más cortos.

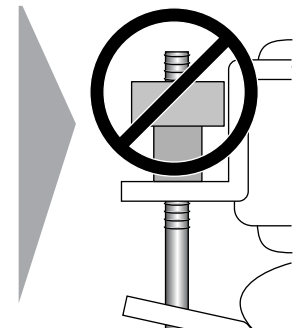

8

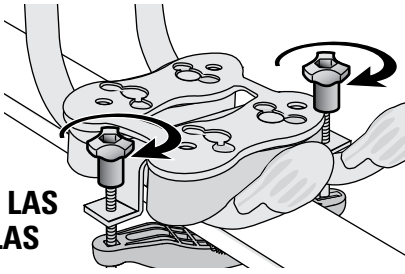

AJUSTE LAS PERILLAS

9

Las almohadillas de espuma pueden subirse, bajarse o desplazarse para apoyar el bote en los puntos de contacto.

Nota: Ciertos acabados con laca del casco pueden pegarse a las almohadillas. Proteja con un paño suave.

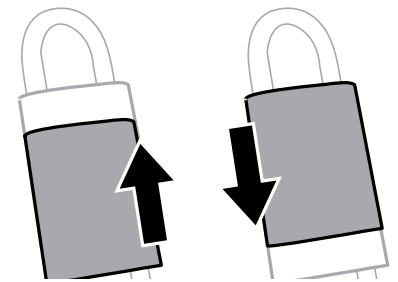

10 CARGUE LA EMBARCACIÓN Y AMÁRRELA.

- Envuelva la correa en la anilla del HullRaiser.
- Lleve las correas hacia arriba y sobre la embarcación para que cuelguen al frente.

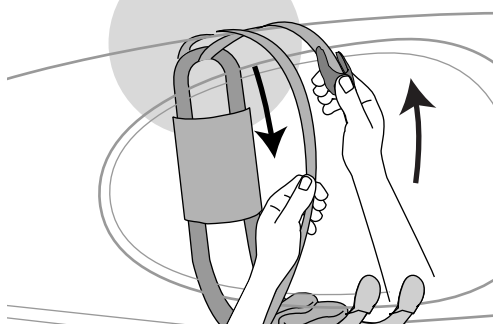

- Deslice la hebilla para que cuelgue del borde superior de la embarcación.
- Pase el extremo de la correa alrededor del soporte o travesaño.

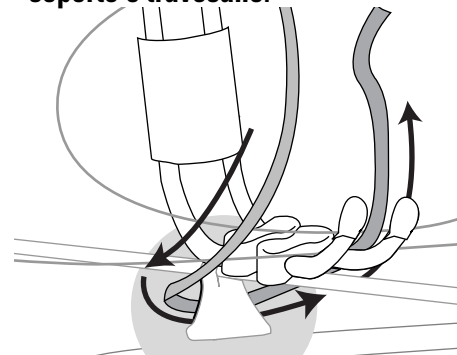

11 ASEGURE LAS CORREAS.

Oprima la hebilla abierta e inserte el extremo de la correa.

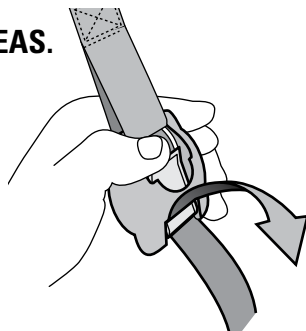

- Para ajustar las correas sostenga y tire.
- Ajustar los extremos de las correas.

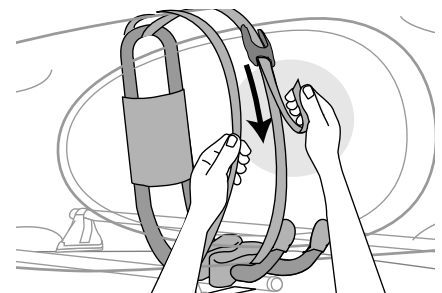

12 Sujete la correa con hebilla al bote.

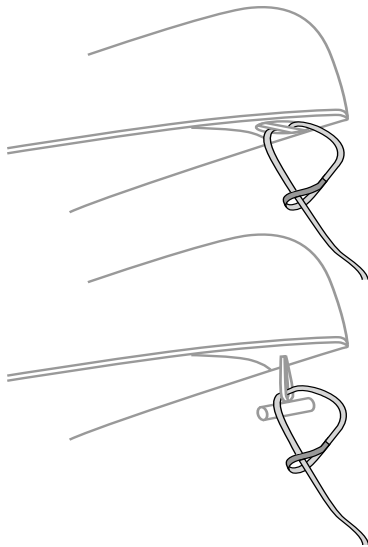

Sujete la correa al asa o a la barra de rescate y tire bien de ella.

13 Pase el gancho por el bucle de la correa llana.

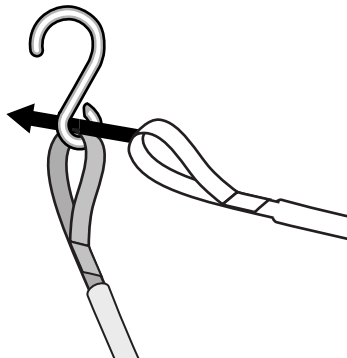

14 Enganche la correa con el gancho de acero a una superficie metálica en el parachoques, bucle de remolque o agujero de la carrocería.

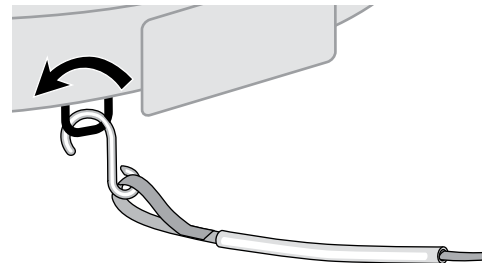

15 Deslice el tubo de plástico para proteger el vehículo en los puntos de contacto.

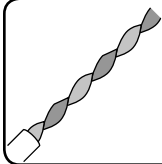

NOTA: Torcer la correa ayudará a reducir la vibración que causa el viento.

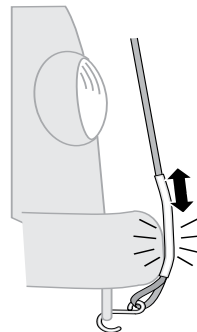

17 Ajuste la tensión de la correa jalando el extremo plano.

- Aplique presión uniforme a las correas delanteras y traseras.
- Fije y ate cualquier exceso de la correa.

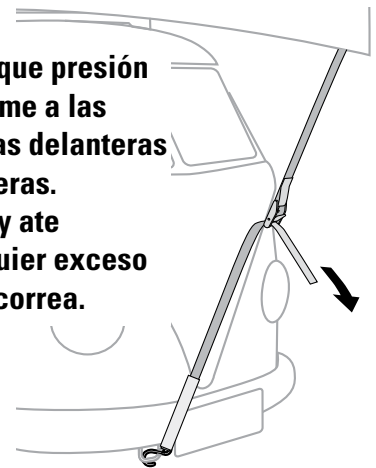

16 Inserte el extremo de la correa llana en la hebilla.

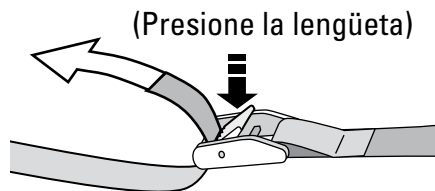

No asegurar la parte delantera y trasera de las cargas a los extremos del vehículo, puede ocasionar daños a la propiedad, lesiones o incluso la muerte.

ANTES DE SALIR DE VIAJE



- Revise el movimiento, meciendo el bote.
- Ajuste nuevamente el herraje si está flojo.
- LEA EN LA PÁGINA SIGUIENTE TODAS LAS PRECAUCIONES NECESARIAS Y LA INFORMACIÓN RELACIONADA A LOS LÍMITES DE PESO.



Revise las correas periódicamente durante el viaje y ajústelas si es necesario. Reemplace toda correa gastada o raída antes de usarla (consulte con su concesionario Yakima).

REMÍTASE A LAS INSTRUCCIONES REFERENTES A LOS ACCESORIOS PARA INFORMARSE SOBRE LAS ADVERTENCIAS IMPORTANTES.



LÍMITES DE PESO

Busque el límite de peso de su parrilla en la Lista de compatibilidad Yakim. No exceda el límite de peso de la parrilla de su vehículo. El peso máximo es 165 lbs (75 kg) salvo indicación en contrario.

SI QUITA EL ACCESORIO, SIGA LAS INSTRUCCIONES PARA VOLVER A INSTALARLO.

Haga las verificaciones de seguridad de las instrucciones para el accesorio antes de cada instalación.

PORTEZUELA TRASERA

Algunas cargas largas pueden impedir que la portezuela trasera se abra completamente.

SIEMPRE PROCEDA CON CUIDADO AL ABRIR LA PORTEZUELA.

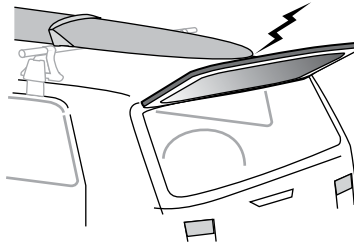

ANTENA

Quizá haya que quitar la antena del techo para evitar interferencia con las cargas largas.

ADVERTENCIA: CERCÍERESE DE QUE TODO EL EQUIPO QUEDÓ ASEGURADO SEGÚN LAS INSTRUCCIONES. LAS UNIONES Y PIEZAS DE MONTAJE PUEDEN AFLOJARSE CON EL TIEMPO. VERIFIQUE ANTES DE CADA USO Y AJUSTE SI ES NECESARIO.

MANTENIMIENTO: Use lubricante no soluble en agua en los tornillos. Use un paño blando con agua y detergente suave para limpiar las partes de plástico.

QUITE EL ACCESORIO ANTES DE ENTRAR EN UN LAVADERO AUTOMÁTICO DE VEHÍCULOS.

ASISTENCIA TÉCNICA O REPUESTOS

Comuníquese con su distribuidor o llame al (888)925-4621 de lunes a viernes, de 7:00 AM a 5:00 PM hora del Pacífico.



Este producto es cubierto por YAKIMA Garantía limitada a vida "Mientras dure el romance"

Para obtener una copia de la garantía limitada, va en línea a www.yakima.com o nos manda correo electrónico en yakwarranty@yakima.com o llamada (888) 925-4621

¡ CONSERVE ESTAS INSTRUCCIONES !