

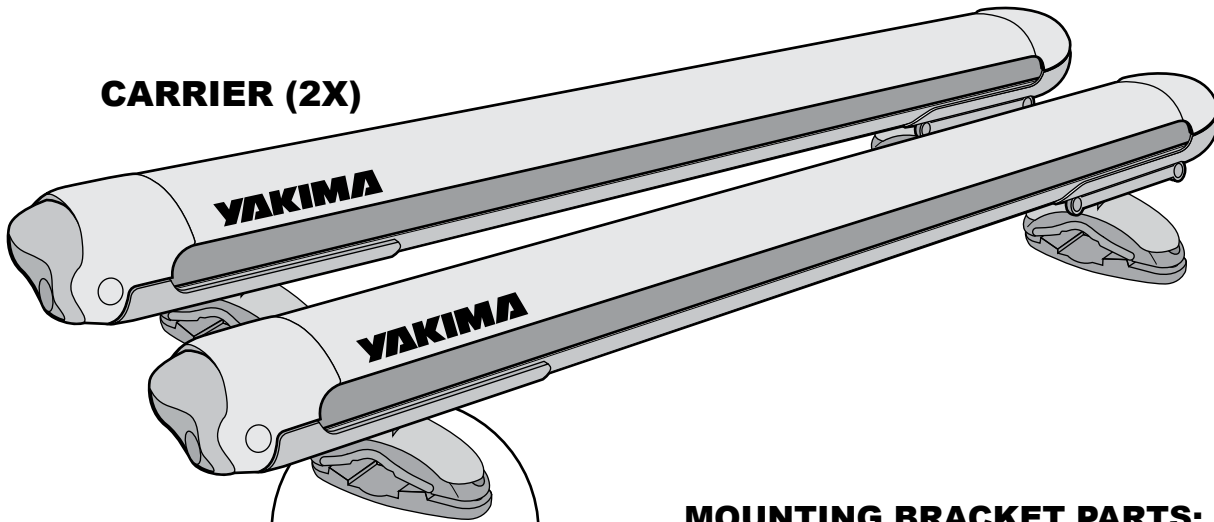

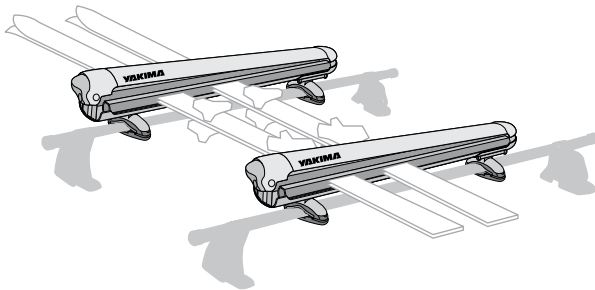





CARRIER (2X)



Universal Mounting Bracket (4x)

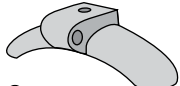

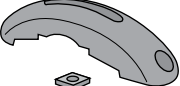
MOUNTING BRACKET PARTS:

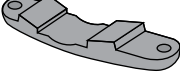
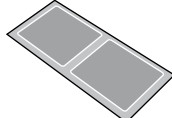
- Hex Wrench (1x) 
- Base Screw (4x) 
- Washer (4x) 
- Slider Top (4x) 
- Bail Screw (8x) *installed* 
- Long Bail Screw (8x) *for some larger factory bars* 
- Upper Bail (4x) 
- Square Nut (4x) 
- Pad (4x) 
- Lower Bail (4x) 
- Vinyl Pad Sheets (2x) *for factory bars* 



IMPORTANT WARNING

IT IS CRITICAL THAT ALL YAKIMA RACKS AND ACCESSORIES BE PROPERLY AND SECURELY ATTACHED TO YOUR VEHICLE. IMPROPER ATTACHMENT COULD RESULT IN AN AUTOMOBILE ACCIDENT, AND COULD CAUSE SERIOUS BODILY INJURY OR DEATH TO YOU OR TO OTHERS. YOU ARE RESPONSIBLE FOR SECURING THE RACKS AND ACCESSORIES TO YOUR CAR, CHECKING THE ATTACHMENTS PRIOR TO USE, AND PERIODICALLY INSPECTING THE PRODUCTS FOR ADJUSTMENT, WEAR, AND DAMAGE. THEREFORE, YOU MUST READ AND UNDERSTAND ALL OF THE INSTRUCTIONS AND CAUTIONS SUPPLIED WITH YOUR YAKIMA PRODUCT PRIOR TO INSTALLATION OR USE. IF YOU DO NOT UNDERSTAND ALL OF THE INSTRUCTIONS AND CAUTIONS, OR IF YOU HAVE NO MECHANICAL EXPERIENCE AND ARE NOT THOROUGHLY FAMILIAR WITH THE INSTALLATION PROCEDURES, YOU SHOULD HAVE THE PRODUCT INSTALLED BY A PROFESSIONAL INSTALLER SUCH AS A QUALIFIED GARAGE OR AUTO BODY SHOP.

CROSSBAR SPREAD

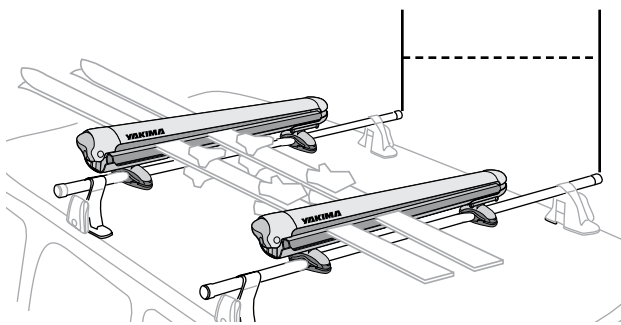

**SKIS AND BOARDS
UNDER 170 cm:**
Crossbar spread must be
between 12" and 24"

**SKIS AND BOARDS
OVER 170 cm:**
Crossbar spread must be
between 12" and 36"



YAKIMA Q TOWERS: DO NOT REPOSITION YOUR TOWERS!

1 REMOVE BASE SCREW

Use hex wrench.

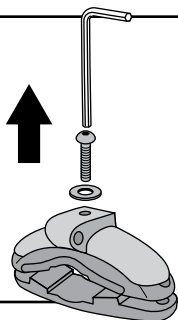

2 REMOVE ONE BAIL SCREW

- Use hex wrench.
- Loosen the remaining screw, but leave it in place.

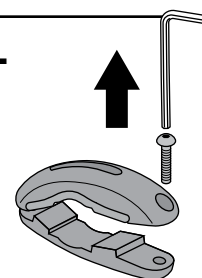

3 FACTORY BARS: CHECK FOR PROPER SCREW LENGTH

- Some factory bars may require the long bail screws.
- Screws must extend below bail.

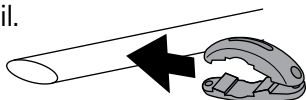

IF SCREWS ARE TOO SHORT, USE THE LONGER SCREWS INCLUDED

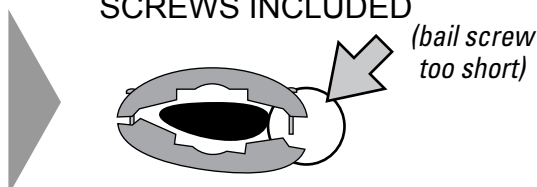

In some cases, the bails may not be parallel.

OK

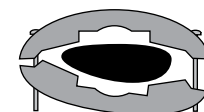

4

**WORK ON A FLAT SURFACE
(not on the roof of the car)**

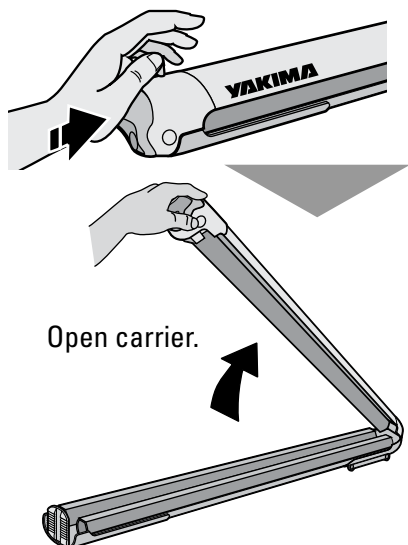

5 ASSEMBLE

- Insert base screw through hole in carrier.
- Position slider top onto screw.

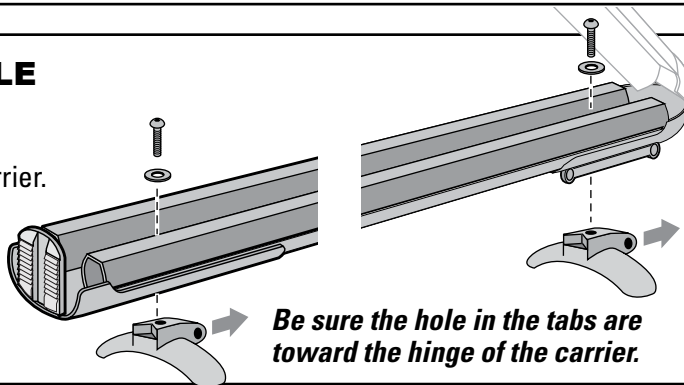

6 ATTACH UPPER BAIL TO SLIDER TOP

- Align the base screw with square nut (inside upper bail.)
- Use hex wrench to engage the screw and nut.
- Do not tighten yet.

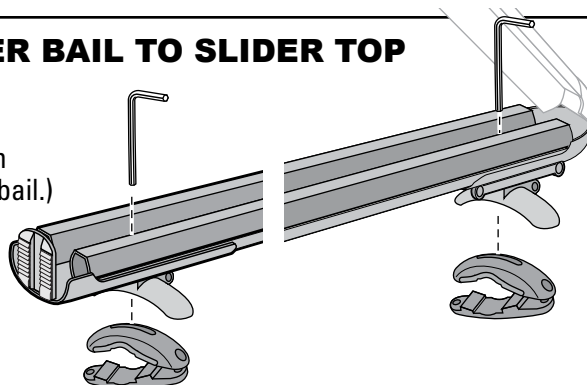

7 STILL WORKING ON A FLAT SURFACE:

Move bails to expose screw hole.

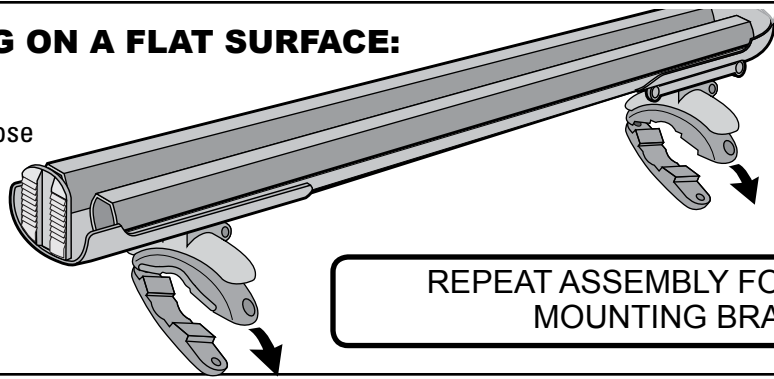

REPEAT ASSEMBLY FOR REMAINING MOUNTING BRACKETS

8 CLOSE CARRIERS WITH FIRM PRESSURE

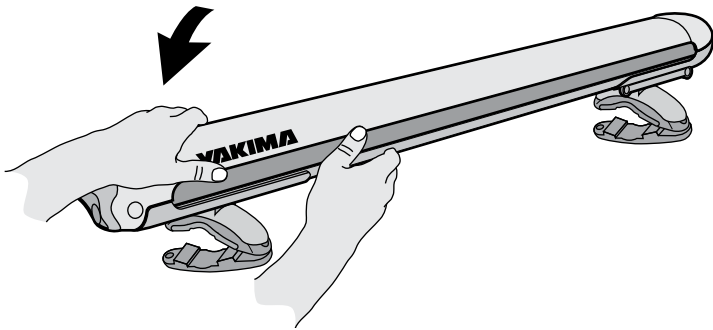

9 INSERT SECOND BAIL SCREW THROUGH UPPER BAIL ONLY

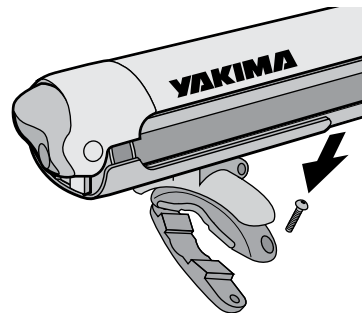

10 SLIDE CARRIER ASSEMBLY ONTO CROSSBAR

ROUND BARS

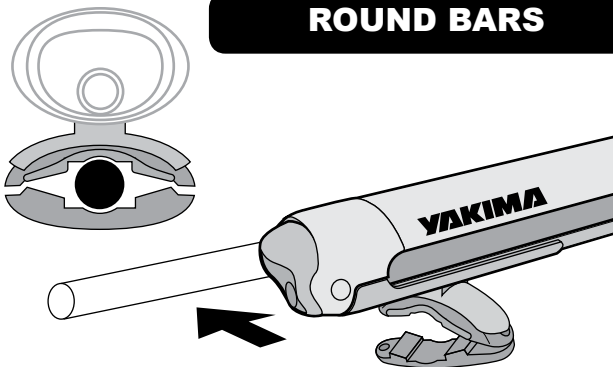

SQUARE BARS

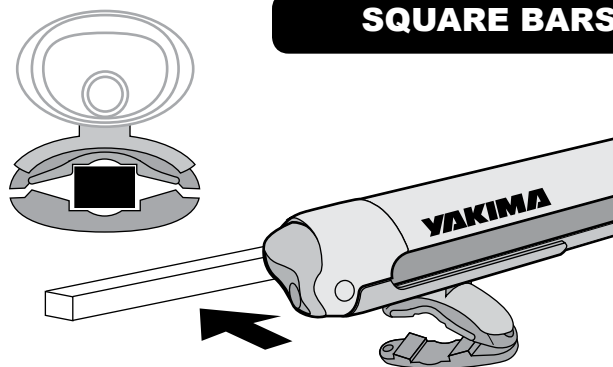

FACTORY BARS

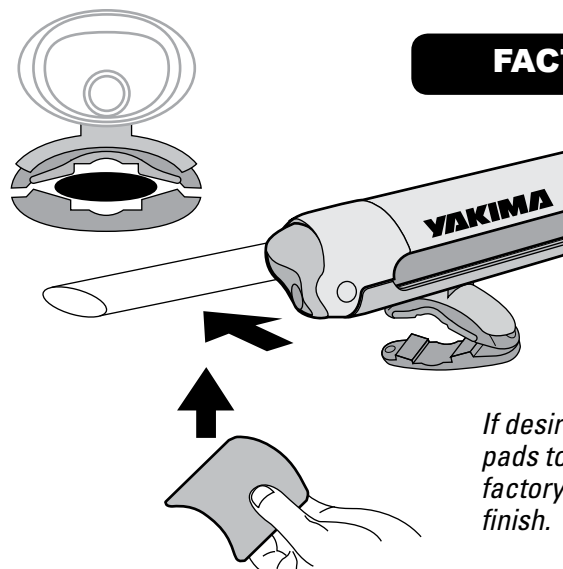

If desired, attach vinyl pads to underside of factory bars to protect finish.

11 SECURE MOUNTING ASSEMBLY

- Slide carrier to expose unsecured bail screw.
- Use hex wrench to tighten both bail screws.

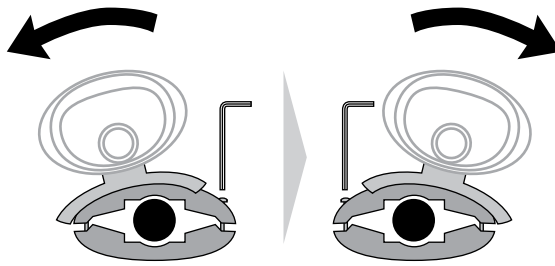

12 OPEN CARRIER

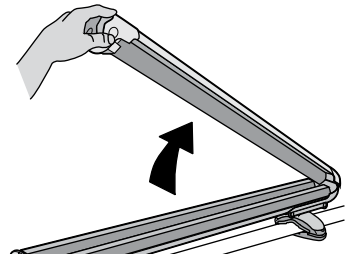

13 TIGHTEN CARRIERS TO MOUNTING BRACKETS

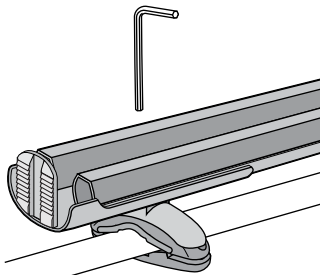

For added security, ensure bail screw heads are covered with the slider top.

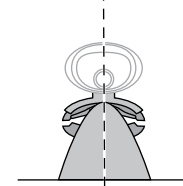

Make sure carriers are vertically aligned and both mounts are at the same angle.

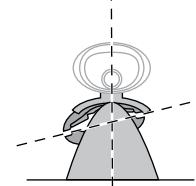

In some cases, the mount will sit at an angle.

14 LOAD SKIS OR SNOWBOARDS

- Lower your bindings first!
- Keep the tips toward the rear of the vehicle.

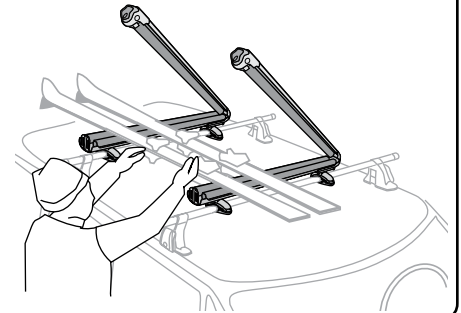

15 VERIFY BINDING CLEARANCE

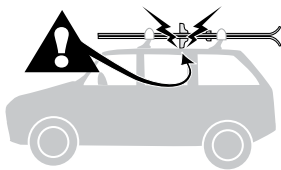

If you have sufficient clearance, PROCEED TO STEP 23

If you need more binding clearance, or if factory bars are arched and cannot align with carriers, CONTINUE TO NEXT STEP

16 SKILIFT ADJUSTMENT: OPEN CARRIERS

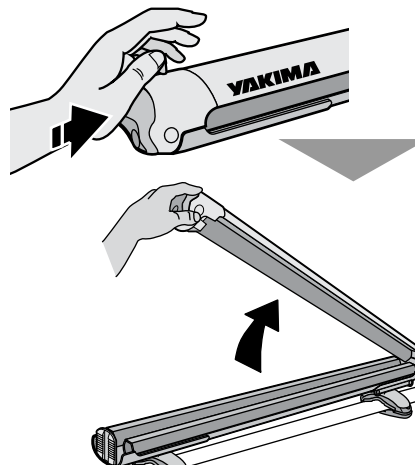

17 LOOSEN FRONT BASE SCREW

DO NOT remove the screw!

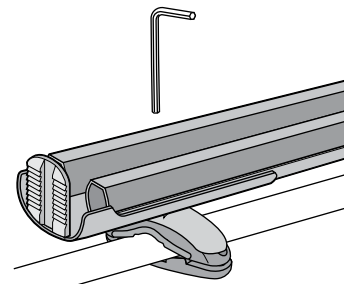

18 REMOVE BASE SCREW AT HINGED SIDE OF CARRIERS

Remove screw closest to hinge.

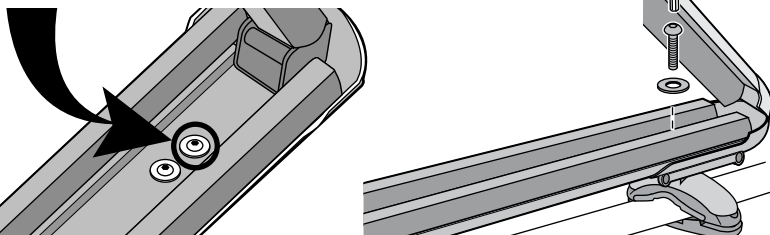

19 LIFT HINGED SIDE OF CARRIER

Reinstall base screw into mounting bracket.

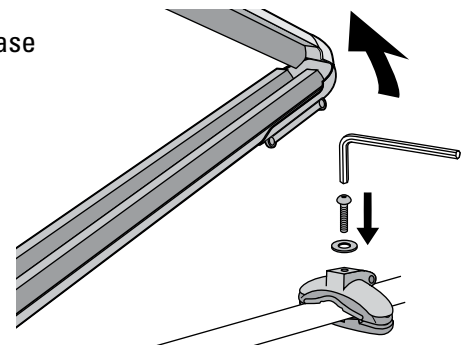

20 REMOVE LIFT BOLT

- Loosen with hex wrench.
- You may need to reposition the mounts to accommodate Ski Lift.

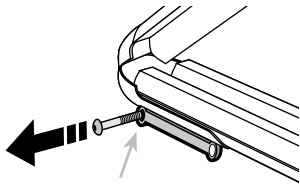

FatCat 6

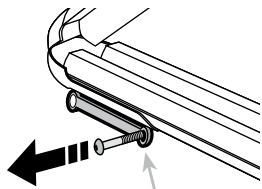

FatCat 4

21 ROTATE LIFT DOWN TOWARD MOUNTING BRACKET

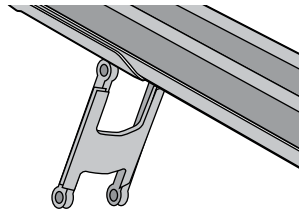

22 ATTACH LIFT TO MOUNTING BRACKET

- Use lift bolt (Step 20).
- Tighten lift bolt completely.
- Re-tighten the front base screw.

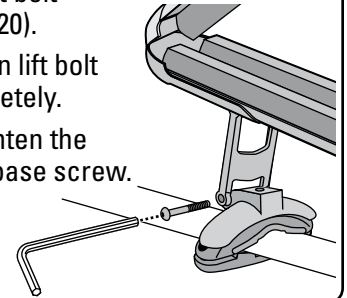

23 Optional Storage for Hex Wrench: (inside carrier)

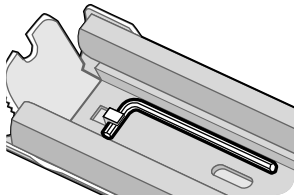

24 CLOSE CARRIERS WITH FIRM PRESSURE

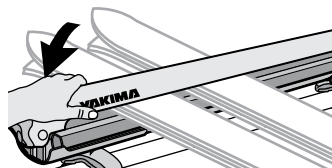

25 VERIFY THE CLOSURE!

- Verify closure of carrier by pulling upward on skis.

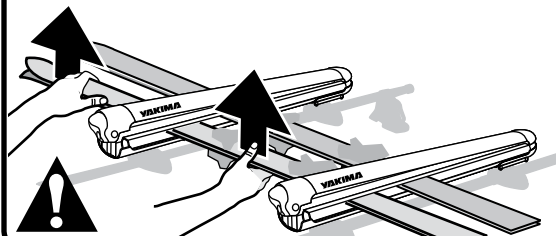

26 INSTALL SKS LOCKS ACCORDING TO LOCK INSTRUCTIONS

(purchased separately).

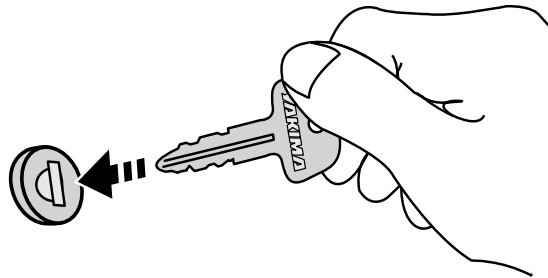

REAR HATCH

ALWAYS USE CAUTION WHEN OPENING YOUR HATCH.

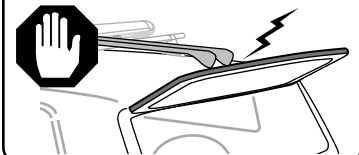

IF YOU REMOVE YOUR CARRIER, FOLLOW INSTRUCTIONS TO REINSTALL.
Follow safety checks in accessory instructions before every installation.

WARNING: BE SURE ALL HARDWARE IS SECURED ACCORDING TO INSTRUCTIONS. ATTACHMENT HARDWARE CAN LOOSEN OVER TIME. CHECK BEFORE EACH USE, AND TIGHTEN IF NECESSARY.

MAINTENANCE: Use non-water soluble lubricant on screws. Use a soft cloth with water and mild detergent to clean plastic parts.

REMOVE RACKS AND CARRIERS BEFORE ENTERING AN AUTOMATIC CAR WASH.

To extend the life of your product, clean and remove the carrier at the end of the season

**TECHNICAL ASSISTANCE
OR REPLACEMENT PARTS**
Contact your dealer or call
(888)925-4621

Monday through Friday,
7:00 AM to 5:00 PM, PST

This product is covered by YAKIMA's
"Love It Till You Leave It" Limited Lifetime Warranty
To obtain a copy of this warranty, go online to www.yakima.com
or email us at yakwarranty@yakima.com
or call (888) 925-4621

KEEP THESE INSTRUCTIONS!



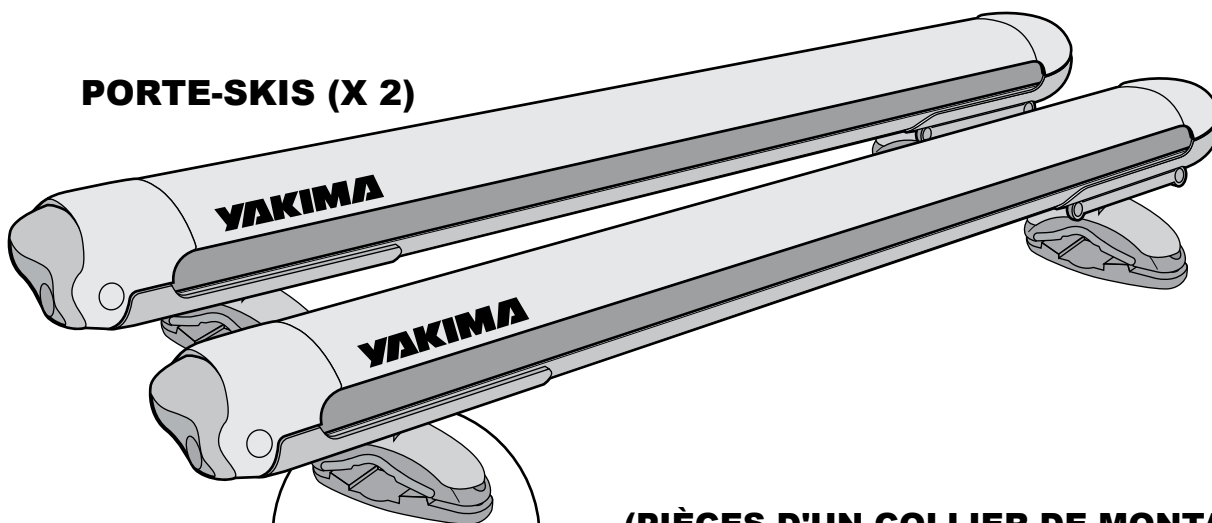

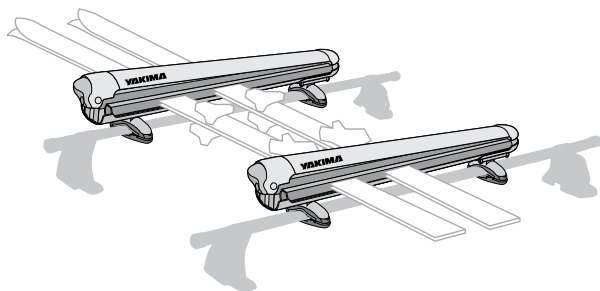

PORTE-SKIS (X 2)



Collier de montage universel (x 4)

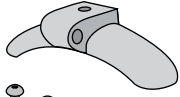

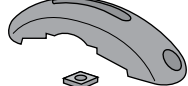
(PIÈCES D'UN COLLIER DE MONTAGE:)

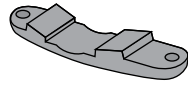
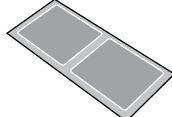
- Clé hexagonale (x 1) 
- Vis d'assemblage (x 4) 
- Rondelle (x 4) 
- Dessus coulissant (x 4) 
- Vis de serrage (x 8) installée 
- Vis de serrage longue (x 8) pour certaines grosses barres d'origine 
- Mâchoire supérieure (x 4) 
- Écrou carré (x 4) 
- Coussinet (x 4) 
- Mâchoire inférieure (x 4) 
- Garniture en vinyle (x 4) pour barres d'origine 



AVERTISSEMENT IMPORTANT:

IL EST IMPÉRATIF QUE LES PORTE-BAGAGES ET LES ACCESSOIRES YAKIMA SOIENT CORRECTEMENT ET SOLIDEMENT FIXÉS AU VÉHICULE. UN MONTAGE MAL RÉALISÉ POURRAIT PROVOQUER UN ACCIDENT D'AUTOMOBILE, QUI POURRAIT ENTRAÎNER DES BLESSURES GRAVES OU MÊME LA MORT, À VOUS OU À D'AUTRES PERSONNES. VOUS ÊTES RESPONSABLE DE L'INSTALLATION DU PORTE-BAGAGES ET DES ACCESSOIRES SUR VOTRE VÉHICULE, D'EN VÉRIFIER LA SOLIDITÉ AVANT DE PRENDRE LA ROUTE ET DE LES INSPECTER RÉGULIÈREMENT POUR EN CONTRÔLER L'ÉTAT, L'AJUSTEMENT ET L'USURE. VOUS DEVEZ DONC LIRE ATTENTIVEMENT TOUTES LES INSTRUCTIONS ET TOUS LES AVERTISSEMENTS ACCOMPAGNANT VOTRE PRODUIT YAKIMA AVANT DE L'INSTALLER ET DE L'UTILISER. SI VOUS NE COMPRENEZ PAS TOUTES LES INSTRUCTIONS ET TOUS LES AVERTISSEMENTS, OU SI VOUS N'AVEZ PAS DE COMPÉTENCES EN MÉCANIQUE ET NE COMPRENEZ PAS PARFAITEMENT LA MÉTHODE DE MONTAGE, VOUS DEVRIEZ FAIRE INSTALLER LE PRODUIT PAR UN PROFESSIONNEL, COMME UN MÉCANICIEN OU UN CARROSSIER COMPÉTENT.

DISTANCE ENTRE LES BARRES TRANSVERSALES

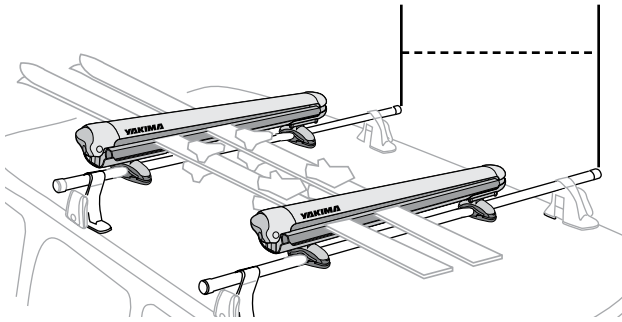

VÉHICULE MUNI DE PIEDS Q YAKIMA : NE PAS DÉPLACER LES PIEDS!



POUR LES SKIS ET LES PLANCHES DE MOINS DE 170 cm :
la distance entre les barres transversales doit être de 30 à 61 cm (12 à 24 po).

POUR LES SKIS ET LES PLANCHES DE PLUS DE 170 cm :
la distance entre les barres transversales doit être de 30 à 92 cm (12 à 36 po).

1 ENLEVER LA VIS D'ASSEMBLAGE

Employer la clé hexagonale.

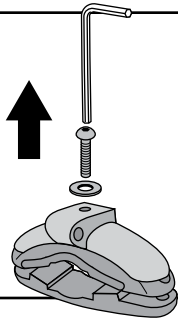

2 ENLEVER UNE DES VIS DE SERRAGE

- Employer la clé hexagonale.
- Desserrer l'autre vis, mais la laisser en place.

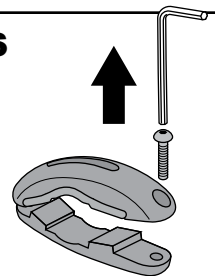

3 BARRES D'ORIGINE : EMPLOYER LES BONNES VIS DE SERRAGE.

- Pour certaines barres d'origine, il faudra peut-être les vis de serrage longues.
- Les vis doivent dépasser sous la mâchoire.

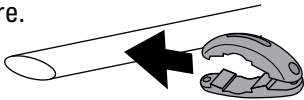

SI LES VIS SONT TROP COURTES, IL FAUT EMPLOYER LES VIS LONGUES FOURNIES

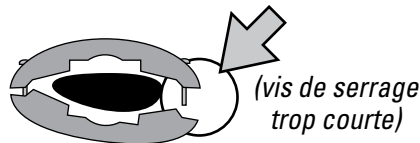

Dans certains cas, les mâchoires ne seront pas parallèles.

OK



4 TRAVAILLER SUR UNE SURFACE PLATE (pas sur le toit de la voiture)



Ouvrir le porte-skis.

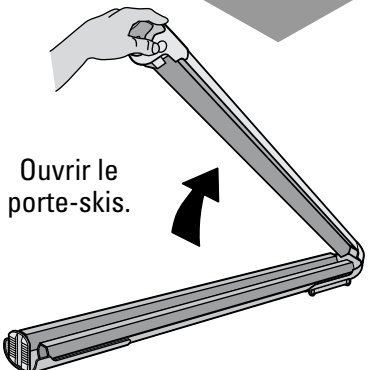

5 ASSEMBLAGE

- Enfiler la vis d'assemblage à travers le trou dans le porte-skis.
- Enfiler le dessus coulissant sur la vis.

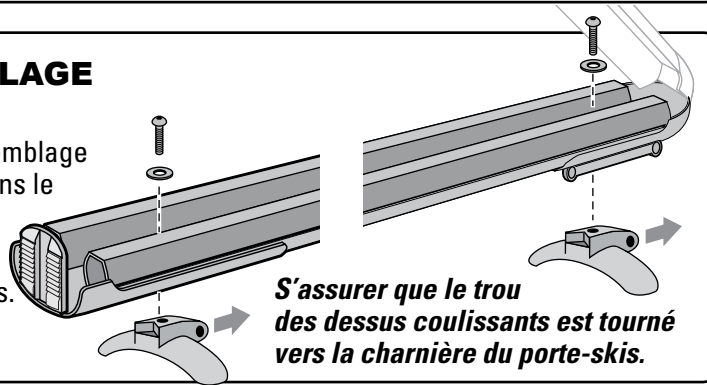

6 FIXER LA MÂCHOIRE SUPÉRIEURE AU DESSUS COULISSANT

- Aligner la vis d'assemblage avec l'écrou carré (à l'intérieur de la mâchoire supérieure).
- Engager la vis dans l'écrou avec la clé hexagonale.
- Ne pas serrer pour le moment.

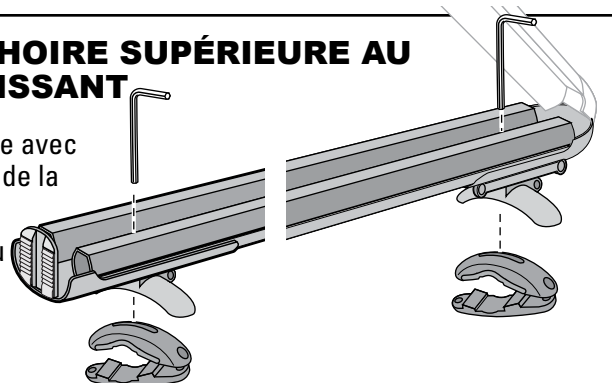

7 TOUJOURS SUR UNE SURFACE PLATE:

Déplacer les mâchoires coulissantes pour avoir accès aux trous de vis.

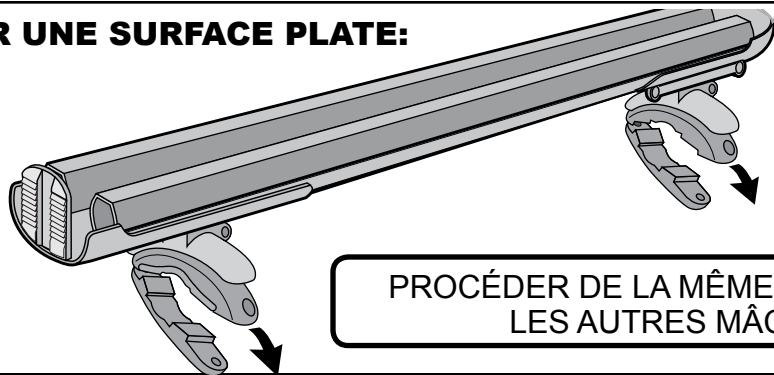

PROCÉDER DE LA MÊME MANIÈRE POUR LES AUTRES MÂCHOIRES

8 FERMER LE PORTE-SKIS EN APPUYANT FERMEMENT

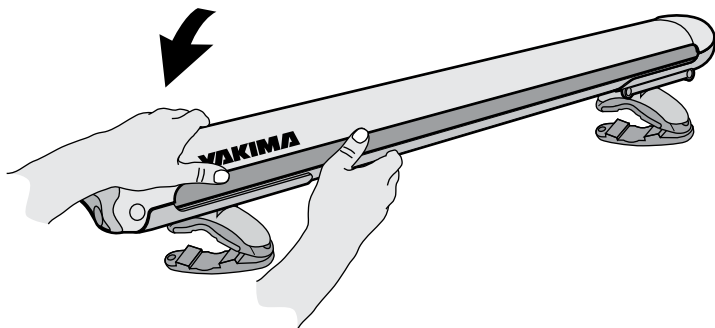

9 ENFILER LA DEUXIÈME VIS DE SERRAGE DANS LA MÂCHOIRE SUPÉRIEURE SEULEMENT

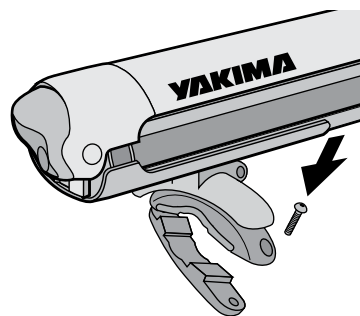

10 ENFILER LES PORTE-SKIS SUR LES BARRES TRANSVERSALES

BARRES RONDES

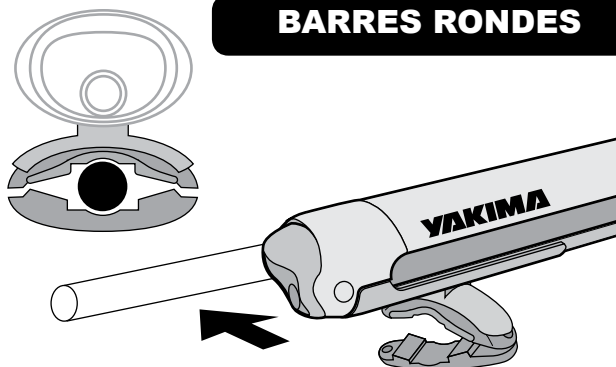

BARRES CARRÉES

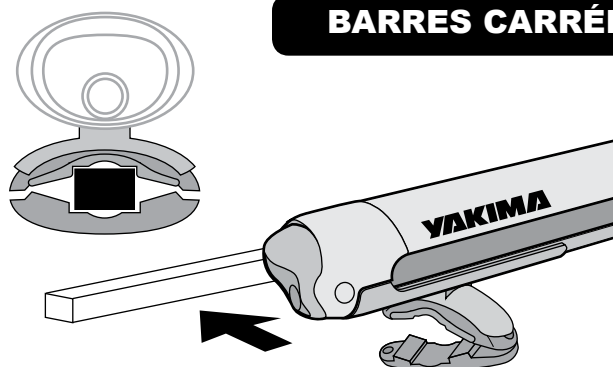

BARRES D'ORIGINE

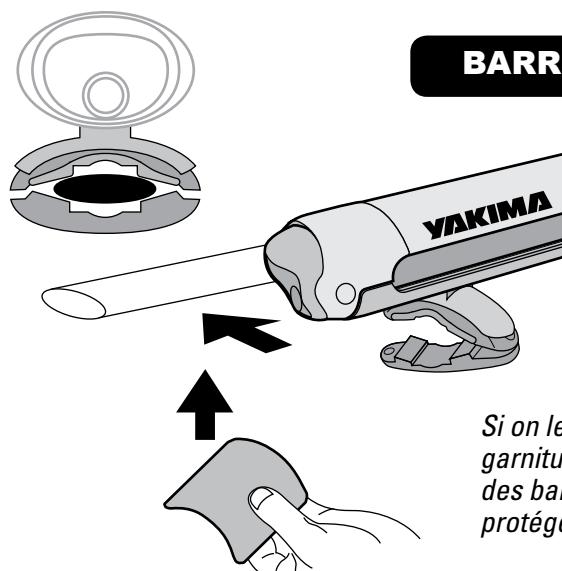

Si on le veut, on peut coller les garnitures en vinyle sur le dessous des barres d'origine pour en protéger le fini.

11 SERRER LES MÂCHOIRES

- Faire coulisser le porte-skis pour avoir accès à la vis de serrage non encore engagée.
- Serrer les deux vis à l'aide de la clé hexagonale.

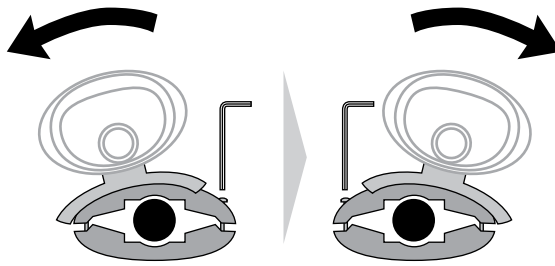

12 OUVRIR LE PORTE-SKIS

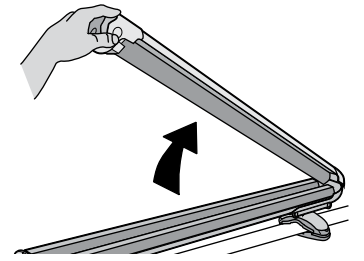

13 SERRER LES PORTE-SKIS SUR LES COLLIERS DE MONTAGE UNIVERSELS

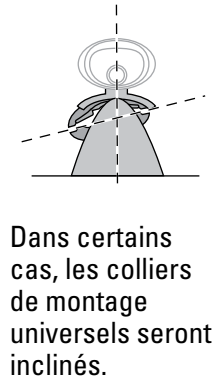
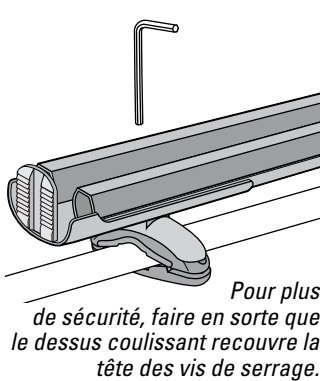

14 CHARGER LES SKIS OU LES PLANCHES.

- Fermer d'abord les fixations !
- Placer les spatules des skis vers l'arrière du véhicule.

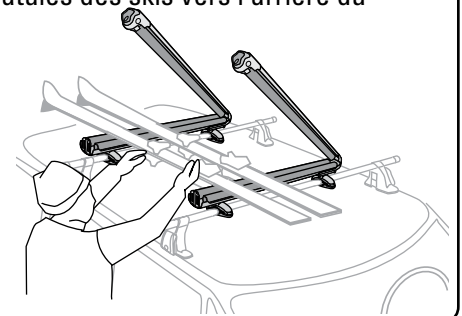

15 VÉRIFIER QUE LES FIXATIONS NE TOUCHENT PAS

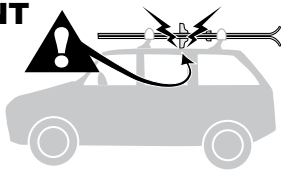

Si les fixations ne touchent pas,
PASSER À L'OPÉRATION 23

Si les fixations touchent au toit du véhicule,
ou si les barres d'origine sont trop cintrées
pour que le porte-skis s'y adapte,

PASSER À L'OPÉRATION
SUIVANTE

16 UTILISATION DES ENTRETOISES SKILIFT : OUVRIR LE PORTE-SKIS

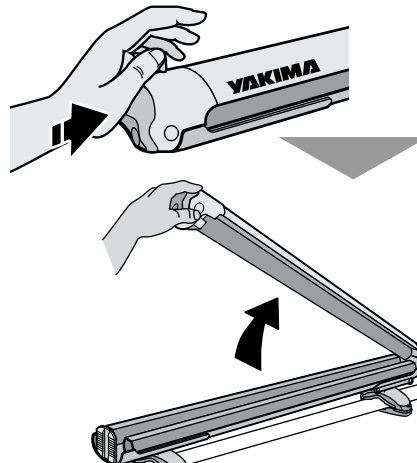

17 DESSERRER LA VIS D'ASSEMBLAGE AVANT

NE PAS enlever la vis!

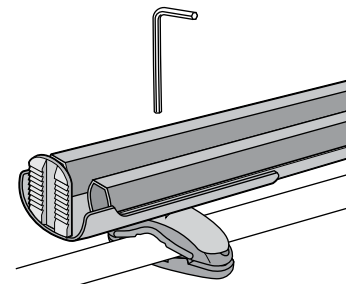

18 ENLEVER LA VIS D'ASSEMBLAGE AU BOUT ARTICULÉ DES PORTE-SKIS

Enlever la vis la plus près de la charnière.

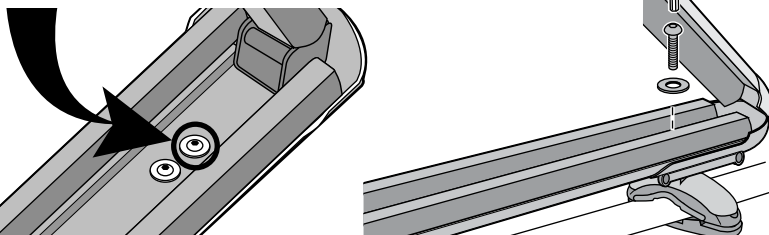

19 SOULEVER LE BOUT ARTICULÉ DU PORTE-SKIS

Remettre en place la vis d'assemblage.

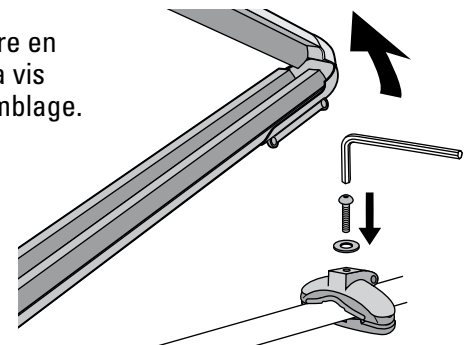

20 ENLEVER LA VIS DE L'ENTRETOISE

- La desserrer avec la clé hexagonale.
- Il faudra peut-être repositionner les colliers.

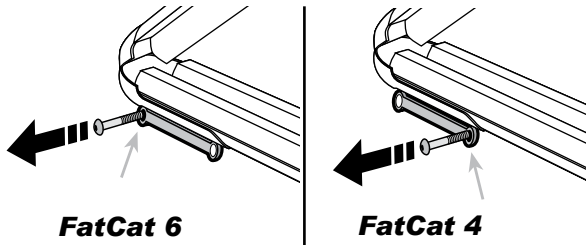

21 DESCENDRE L'ENTRETOISE VERS LE COLLIER

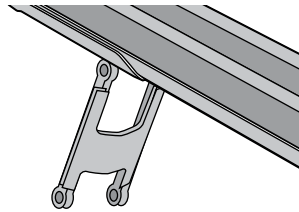

22 FIXER L'ENTRETOISE AU COLLIER

- Employer la vis enlevée à l'opération 20.
- Serrer la vis complètement.
- Resserrer la vis d'assemblage avant

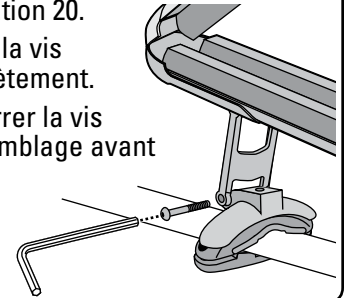

23 On peut si l'on veut ranger la clé hexagonale dans le porte-skis.

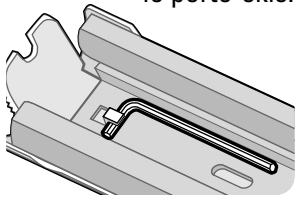

24 FERMER LES PORTE-SKIS EN APPLIQUANT UNE PRESSION FERME

Un seul clic pour fermer.

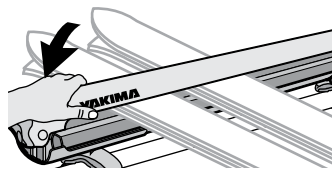

25 VÉRIFIER LA FERMETURE !

- Vérifier la fermeture du porte-skis en tirant les skis vers le haut.

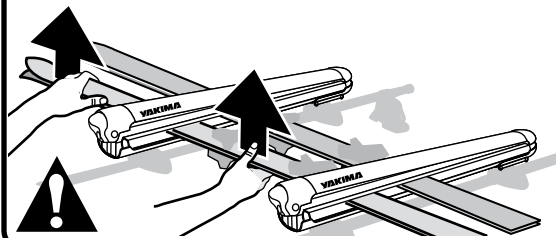

26 POSER LES SERRURES SKS EN SUIVANT LES INSTRUCTIONS QUI LES ACCOMPAGNENT

(les serrures s'achètent à part)

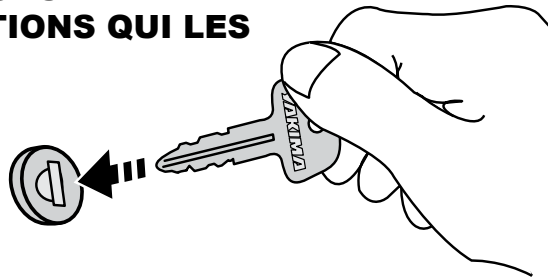

HAYON

TOUJOURS OUVRIR LE HAYON AVEC PRUDENCE.

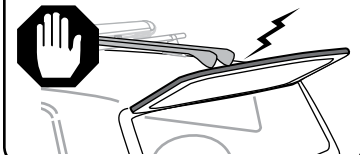

SI L'ON ENLÈVE LE PORTE-SKIS, SUIVRE LES INSTRUCTIONS POUR LE REMETTRE EN PLACE.
Respecter les consignes de sécurité figurant dans les instructions avant chaque montage.

ATTENTION : S'ASSURER QUE LE MONTAGE EST SOLIDE ET CONFORME AUX INSTRUCTIONS. LES DISPOSITIFS DE FIXATION PEUVENT SE DESSERRER À LA LONGUE. LES INSPECTER AVANT CHAQUE UTILISATION ET LES RESSERRER AU BESOIN.

ENTRETIEN : lubrifier les boulons avec un lubrifiant non soluble à l'eau.
Nettoyer les pièces en plastique avec un chiffon, de l'eau et un savon doux.

ENLEVER LES PORTE-SKIS ET LE PORTE-BAGAGES AVANT DE PASSER DANS UN LAVE-AUTO AUTOMATIQUE.

Pour que le produit dure plus longtemps, nettoyer et enlever le porte-skis à la fin de la saison.

RENSEIGNEMENTS TECHNIQUES OU PIÈCES DE RECHANGE, prière de contacter votre dépositaire ou appeler au (888) 925-4621, du lundi au vendredi entre 7h et 17h, heure du Pacifique.

Ce produit est couvert par la garantie limitée « Tant que durera notre histoire d'amour » YAKIMA. Pour se procurer une copie de cette garantie, aller en ligne à www.yakima.com ou nous envoyer un courriel à yakwarranty@yakima.com ou appeler au (888) 925-4621.

CONSERVER CES INSTRUCTIONS!



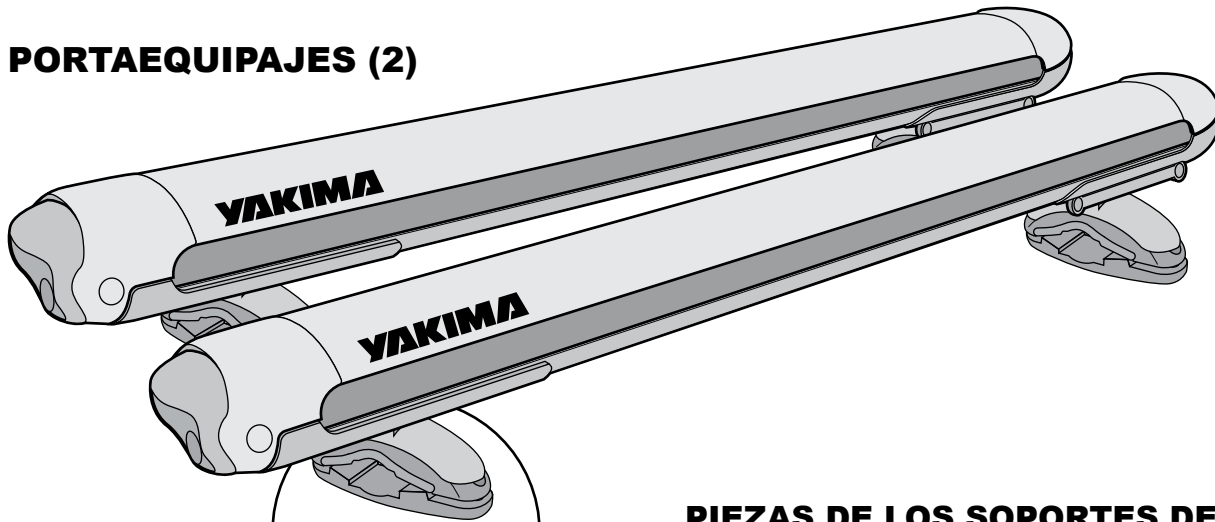

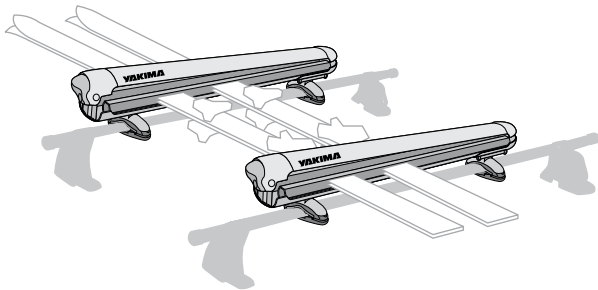

PORTAEQUIPAJES (2)



Soportes de montaje universales (4)

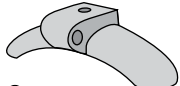

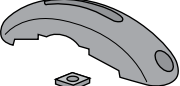
PIEZAS DE LOS SOPORTES DE MONTAJE:

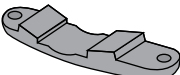
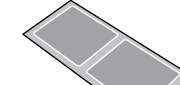
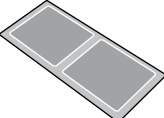
- Llave hexagonal (1) 
- Tornillos para base (4) 
- Arandelas (4) 
- Topes deslizantes (4) 
- Tornillos de mordaza (8) instalados 
- Tornillos de mordaza largos (8) para barras de fábrica más grande 
- Mordazas superiores (4) 
- Tuercas cuadradas (4) 
- Almohadillas (4) 
- Mordazas inferiores (4) 
- Almohadillas de vinilo (2) para las barras de fábrica 



ADVERTENCIA IMPORTANTE

ES ESENCIAL QUE TODOS LOS PORTAEQUIPAJES Y ACCESORIOS DE YAKIMA ESTÉN INSTALADOS APROPIADAMENTE A SU VEHÍCULO. UNA INSTALACIÓN INADECUADA PODRÍA CAUSAR UN ACCIDENTE AUTOMOVILÍSTICO Y PRODUCIR LESIONES GRAVES O MORTALES A USTED U OTRAS PERSONAS. USTED ES RESPONSABLE DE SUJETAR BIEN LOS PORTAEQUIPAJES Y ACCESORIOS A SU VEHÍCULO, COMPROBAR LA INSTALACIÓN ANTES DEL USO Y EXAMINAR PERIÓDICAMENTE EL AJUSTE, GRADO DE DESGASTE O DAÑO DE LOS PRODUCTOS. POR LO TANTO, DEBERÁ LEER Y COMPRENDER TODAS LAS INSTRUCCIONES Y PRECAUCIONES QUE VIENEN CON EL PRODUCTO DE YAKIMA ANTES DE INSTALARLO O USARLO. SI NO ENTIENDE TODAS LAS INSTRUCCIONES Y PRECAUCIONES O NO TIENE NINGUNA EXPERIENCIA MECÁNICA NI ESTÁ BIEN FAMILIARIZADO CON LOS PROCEDIMIENTOS DE INSTALACIÓN, DEBERÁ HACER INSTALAR EL PRODUCTO CON UN INSTALADOR PROFESIONAL, COMO UN TALLER ACREDITADO.

DISTANCIA REQUERIDA ENTRE LAS BARRAS TRANSVERSALES

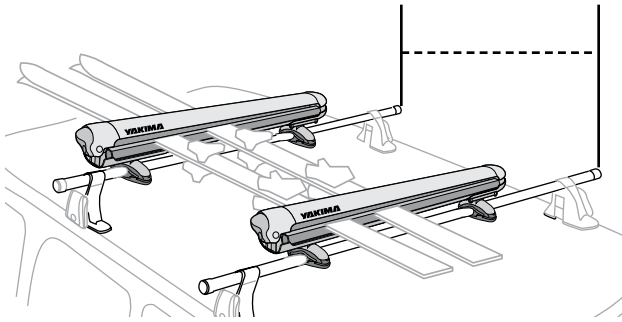

TORRES Q YAKIMA: ¡NO REPOSICIONE SUS TORRES!



ESQUÍ Y TABLAS CON MENOS DE 170 cm:
La distancia entre las barras deberá ser entre 30 y 60 cm

ESQUÍ Y TABLAS CON MÁS DE 170 cm:
La distancia entre las barras deberá ser entre 30 y 90 cm

1 RETIRE EL TORNILLO PARA BASE

Use la llave hexagonal.

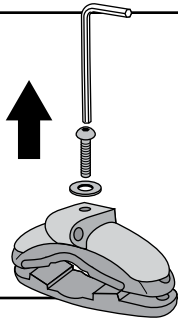

2 RETIRE UN TORNILLO DE MORDAZA

- Use la llave hexagonal.
- Afloje el tornillo restante pero déjelo en su lugar.

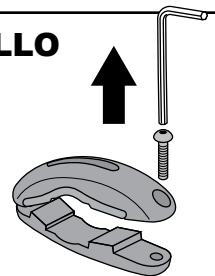

3 BARRAS DE FÁBRICA: REVISE QUE EL LARGO DE LOS TORNILLOS SEA EL APROPIADO

- Algunas barras de fábrica podrían necesitar los tornillos de mordaza largos.
- Los tornillos deben salir por debajo de la mordaza.

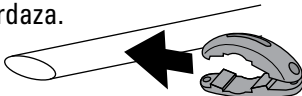

SI LOS TORNILLOS SON DEMASIADO PEQUEÑOS, USE LOS TORNILLOS MÁS LARGOS PROVISTOS.

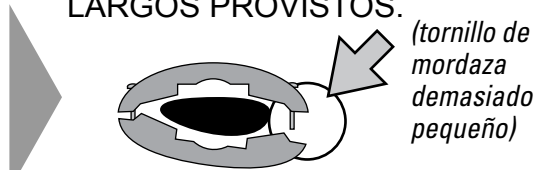

En algunos casos, las mordazas podrían quedar disparejas

Correctos



4

TRABAJE EN UNA SUPERFICIE PLANA (no sobre el techo del vehículo)



Abra el portaequipajes.

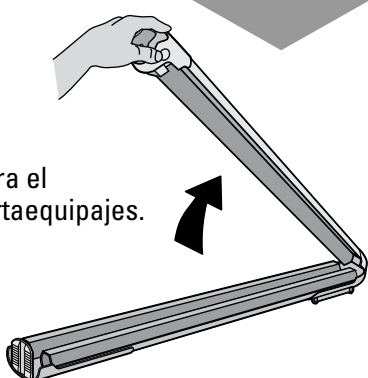

5 ENSAMBLE

- Inserte el tornillo para base por el agujero en el portaequipajes.
- Coloque el tope deslizante en el tornillo.

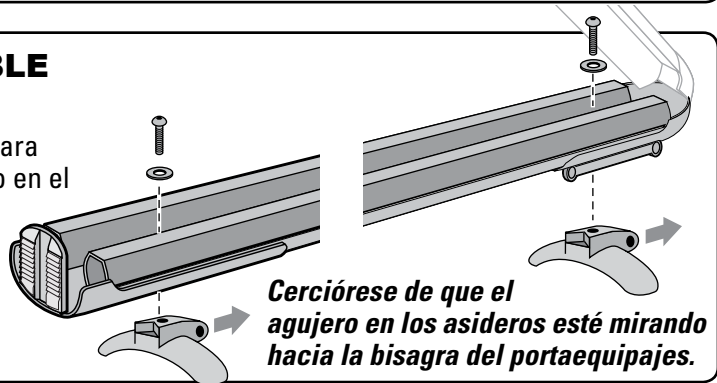

Cerciórese de que el agujero en los asideros esté mirando hacia la bisagra del portaequipajes.

6 UNA LA MORDAZA SUPERIOR AL TOPE DESLIZANTE

- Alinee el tornillo para base con la tuerca cuadrada (dentro de la mordaza superior).
- Use la llave hexagonal para unir el tornillo y la tuerca.
- No ajuste todavía.

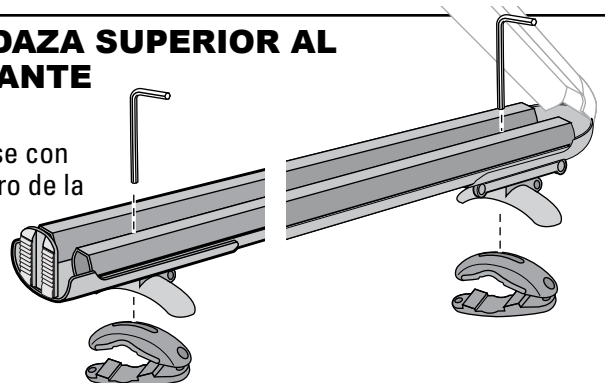

7 CONTINÚE TRABAJANDO EN UNA SUPERFICIE PLANA:

Mueva las mordazas para dejar expuestos los agujeros de los tornillos.

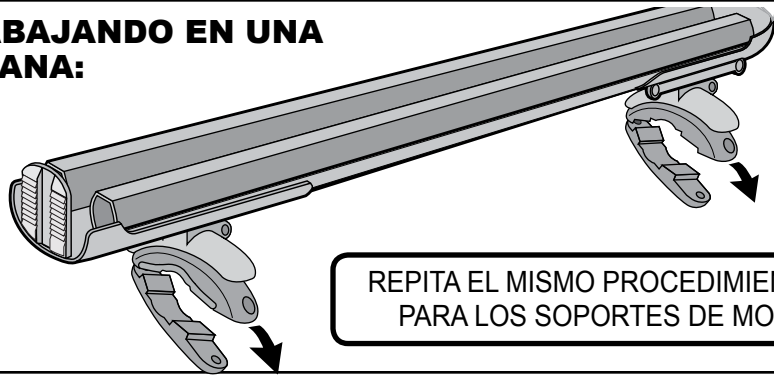

REPITA EL MISMO PROCEDIMIENTO DE ENSAMBLAJE PARA LOS SOPORTES DE MONTAJE RESTANTES

8 CIERRE EL PORTAEQUIPAJES PRESIONANDO CON FIRMEZA

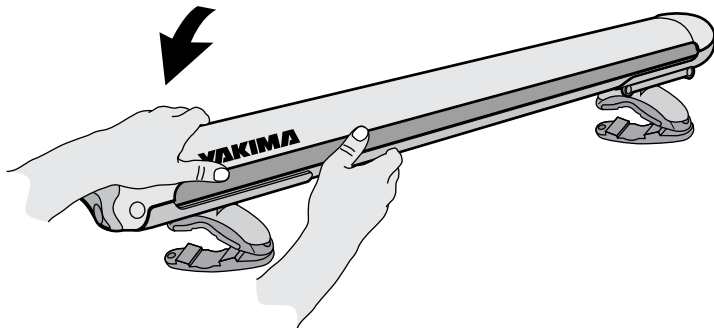

9 INSERTE EL SEGUNDO TORNILLO DE MORDAZA POR LA MORDAZA SUPERIOR ÚNICAMENTE

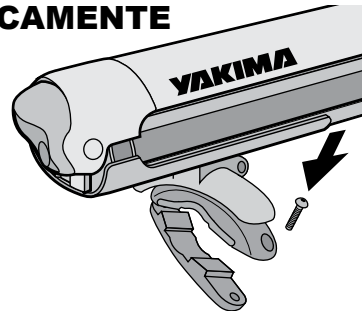

10 DESLICE EL MONTAJE DEL PORTAEQUIPAJES ALREDEDOR DE LA BARRA TRANSVERSAL

BARRAS REDONDAS

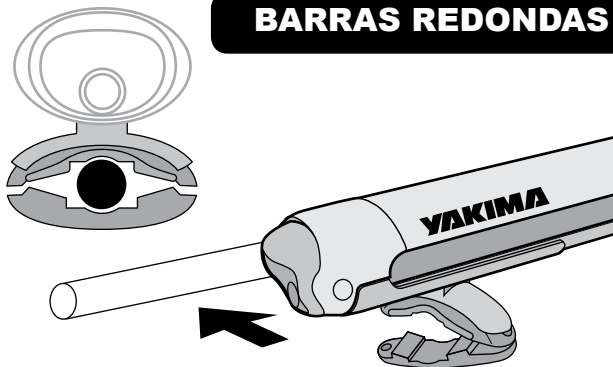

BARRAS CUADRADAS

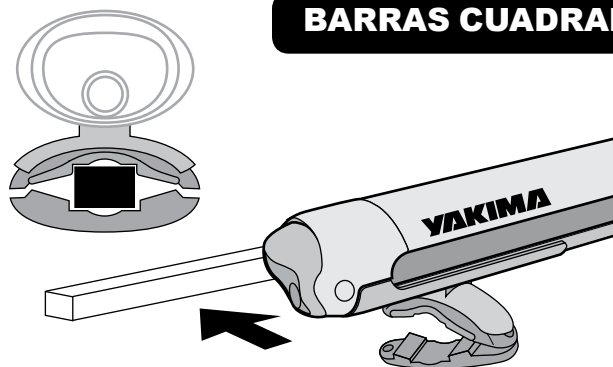

BARRAS DE FÁBRICA

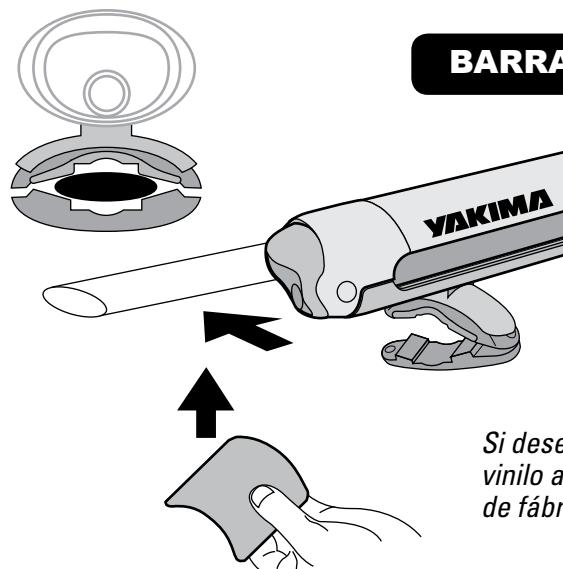

Si desea, coloque almohadillas de vinilo a la parte inferior de las barras de fábrica para proteger su acabado.

11 ASEGURE EL MONTAJE

- Mueva el portaequipajes para dejar expuestos los tornillos de mordaza no ajustados.
- Use la llave hexagonal para ajustar ambos tornillos de mordaza.

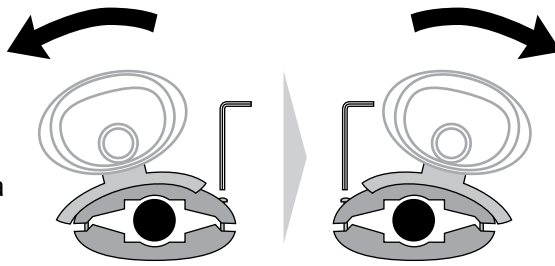

12 ABRA EL PORTAEQUIPAJES

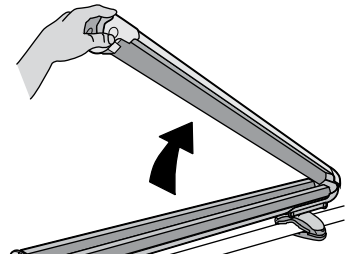

13 AJUSTE EL PORTAEQUIPAJES A LOS SOPORTES DE MONTAJE

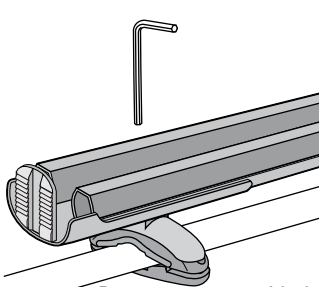

Para mayor seguridad, cerciórese de que el tope deslizante cubra las cabezas de los tornillos de mordaza.

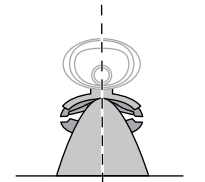

Cerciórese de que el portaequipaje esté alineado verticalmente y que ambos montajes estén en el mismo ángulo.

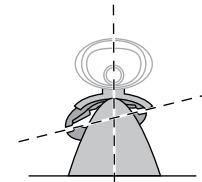

En algunos casos, el montaje se apoyará en un ángulo.

14 CARGUE LOS ESQUÍ O LAS TABLAS DE SNOWBOARD

- ¡Baje primero las fijaciones!
- Mantenga las puntas hacia la parte de atrás del vehículo.

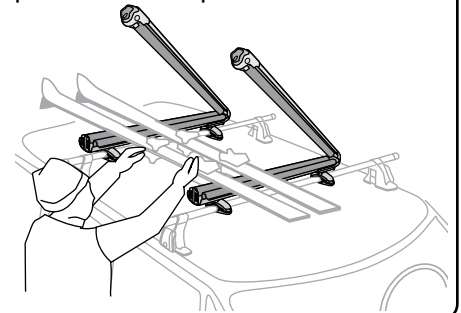

15 VERIFIQUE SI HAY ESPACIO PARA LAS FIJACIONES

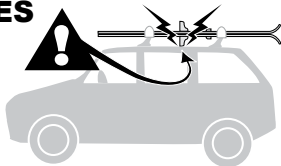

Si tiene suficiente espacio,

CONTINÚE EN EL PASO 23

Si necesita más espacio o si las barras de fábrica están arqueadas y no pueden alinearse con el portaequipajes, CONTINÚE EN EL SIGUIENTE PASO

16 AJUSTE DEL ELEVADOR DE ESQUÍ: ABRA EL PORTAEQUIPAJES

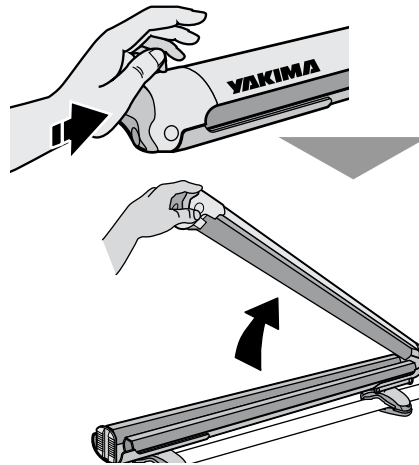

17 AFLOJE EL TORNILLO PARA BASE DELANTERO

¡NO saque el tornillo!

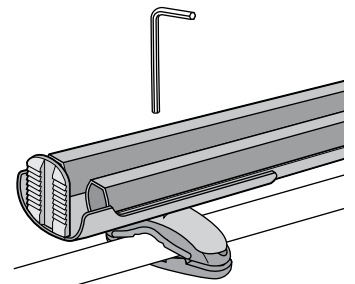

18 RETIRE EL TORNILLO PARA BASE EN EL LADO CON BISAGRA DEL PORTAEQUIPAJES

Retire el tornillo más cercano al lado con bisagra.

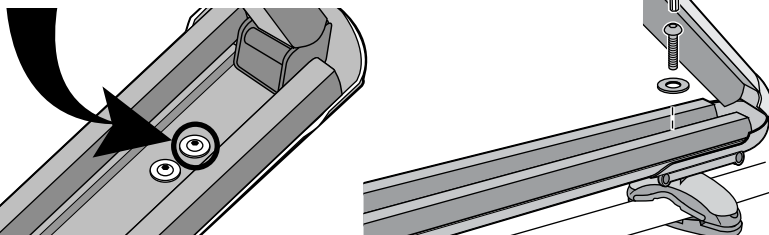

19 LEVANTE EL LADO CON BISAGRA DEL PORTAEQUIPAJES

Vuelva a colocar el tornillo para base en el soporte de montaje.

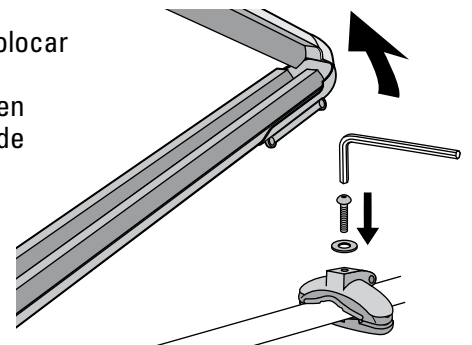

20 RETIRE EL PERNO DEL ELEVADOR

- Desajuste con la llave hexagonal.
- Necesitará volver a colocar los soportes para acomodar el elevador de esquí.

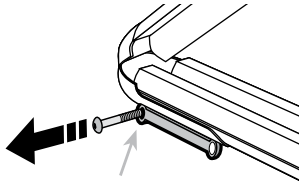

FatCat 6

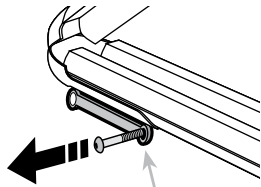

FatCat 4

21 ROTE EL ELEVADOR HACIA ABAJO CON DIRECCIÓN AL SOPORTE DE MONTAJE

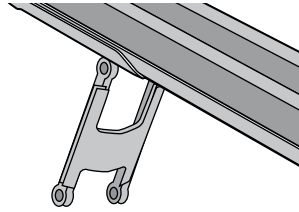

22 SUJETE EL ELEVADOR AL SOPORTE DE MONTAJE

- Use el perno del elevador (Paso 20).
- Ajuste completamente el perno del elevador.
- Ajuste el tornillo para base delantero.



23 LUGAR OPCIONAL PARA GUARDAR LA LLAVE HEXAGONAL:

(dentro del portaequipajes)

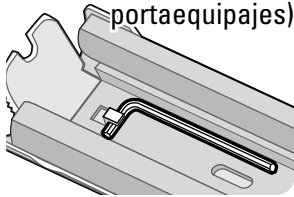

24 CIERRE EL PORTAEQUIPAJES PRESIONANDO CON FIRMEZA

Un simple clic para cerrar.

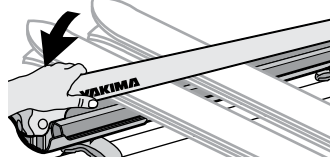

25 ¡VERIQUE QUE ESTÉ BIEN CERRADO!

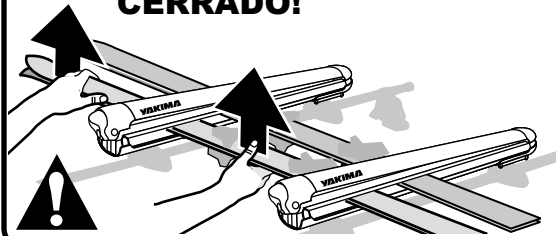

- Tire hacia arriba los esquí para verificar el cerrado del portaequipajes.

26 INSTALE EL SISTEMA DE CERRADURAS CON MISMA LLAVE (SKS) SIGUIENDO LAS INSTRUCCIONES

(se vende por separado)

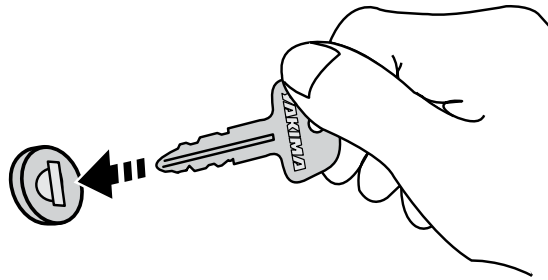

PUERTAS TRASERAS

SIEMPRE TENGA CUIDADO CUANDO ABRA LA PUERTA TRASERA DE SU VEHÍCULO

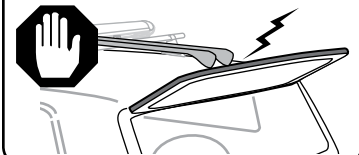

SI RETIRA EL PORTAEQUIPAJES, SIGA LAS INSTRUCCIONES DE REINSTALACIÓN. Realice las revisiones de seguridad indicadas en las instrucciones de los accesorios, antes de cada instalación.

ADVERTENCIA: CERCÍORSE DE QUE TODO EL HERRAJE ESTÉ ASEGURADO SEGÚN LAS INSTRUCCIONES. CON EL TIEMPO, EL HERRAJE PUEDE AFLOJARSE. REVÍSELO ANTES DE CADA USO Y AJÚSTELO SI ES NECESARIO.

MANTENIMIENTO: Use lubricantes no solubles en agua para los tornillos. Use un paño suave con solución jabonosa para limpiar las piezas de plástico.

RETIRE TODOS LOS PORTAEQUIPAJES ANTES DE ENTRAR A UN ESTABLECIMIENTO PARA LAVADO AUTOMÁTICO DE AUTOMÓVILES.

Para extender la vida del producto, limpie y retire el portaequipajes al final de la temporada.

ASISTENCIA TÉCNICA O PIEZAS DE REPUESTO

Comuníquese con su distribuidor o llame al (888)925-4621, de lunes a viernes, de 7:00 a 17:00 horas, hora estándar del Pacífico.

Este producto está cubierto por la garantía limitada a vida "mientras dure el romance" de Yakima. Para obtener una copia de esta garantía, visítenos en www.yakima.com, envíenos un correo electrónico a yakwarranty@yakima.com o llámenos al (888) 925-4621.

¡CONSERVE ESTAS INSTRUCCIONES!