



TAKE IT EASY.

Hitch Fitting Tips

ENSURING THE PERFECT FIT ON A HITCH RECEIVER

THINGS YOU WILL NEED



FIRST

Determine Hitch Class and Size

Our hitch racks are designed and tested to work in Class I, II, III and IV receivers; we DO NOT fit Class V receivers.

To figure out which class your receiver falls into check the sticker on the side of the receiver. If there is no sticker present and the hitch came pre-installed, check the vehicle owner's manual under "Towing". Otherwise you can check with the dealership or manufacturer.

You will also need to determine what size hitch receiver you have. It will either be 2" wide or 1.25" wide. Measure the opening of the receiver.

NEXT

Use the Chart on next page to Match Products

Use the chart on the next page to determine what products are compatible with your hitch Class receiver.

LAST

Follow Fit Measurements

Because hitch receivers can be installed on the vehicle in many different ways it is important to check the provided fit measurements for compatibility. Find the products that fit your Class receiver and locate the A,B,C,D,E measurements that associate with the product.

Hitch Class	Size	Tongue weight Capacity	Tow weight Capacity
Class I	1 1/4"	Up to 200lbs	Up to 2000lbs
Class II	Usually 1 1/4"	Up to 350lbs	Up to 3500lbs
Class III	Usually 2"	Up to 800lbs	Up to 8000lbs
Class IV	2" or 2 1/2"	Up to 1000lbs	Up to 10000lbs

FIT MEASUREMENT A

An obstacle inside or behind the hitch can be present.

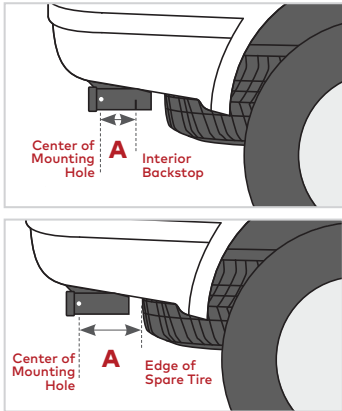

FIT MEASUREMENT B

Make sure the bumper will not interfere with the Yakima hitch rack.

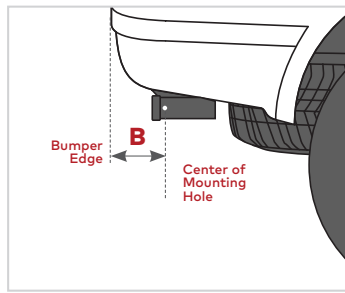

FIT MEASUREMENT C,D

A spare-tire may interfere with the install of a rack.

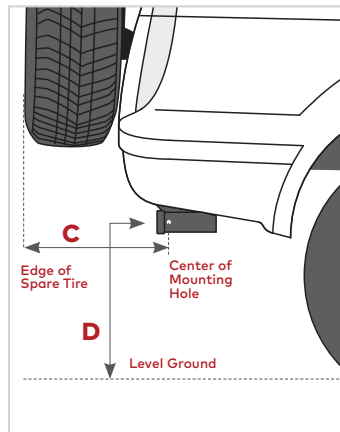

FIT MEASUREMENT E

Distance from edge of receiver to center of mounting hole.

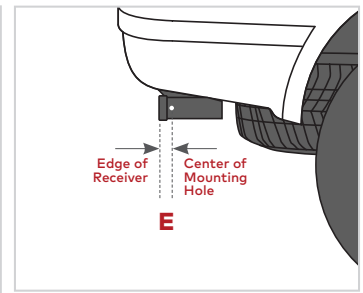

HITCH RACK	FIT MEASUREMENT					RV APPROVED	CLASS COMPATIBILITY			
	A	B	C	D	E		Class I	Class II	Class III	Class IV
OnRamp™ 2"	3" Min.	5 1/8" Max.	5 1/8" Max.	10 ★	1.5" Min.	✓ (40lbs./bike)			✓	✓
OnRamp™ 1.25"	2" Min.	6 1/4" Max.	5 1/8" Max.	10 ★	1.5" Min.		◆	✓		
HangOver™ 6	3" Min.	8" Max.	13" Max.	12" Min.	1.5" Min.				✓	✓
HangOver™ 4	3" Min.	8" Max.	13" Max.	10" Min.	1.5" Min.				✓	✓
BackSwing™	2 7/8" Min.	8 1/4" Max.	6 1/2" Max.	10 ★	1.5" Min.				✓	✓
Dr.Tray™ 1.25"	3 3/4" Min.	6 1/4" Max.	9" Max.	10 ★	2.375" Min.				✓	✓
Dr.Tray™ 2"	2 7/8" Min.	9" Max.	9 3/4" Max.	10 ★	1.5" Min.				✓	✓
HoldUp™ 1.25"	2" Min.	9 1/2" Max.	10 1/2" Max.	10 ★	1.5" Min.			✓		
HoldUp™ 2"	2 7/8" Min.	9" Max.	9 3/4" Max.	10 ★	1.5" Min.				✓	✓
HoldUp™ 1.25"	2" Min.	9 1/2" Max.	10 1/2" Max.	10 ★	1.5" Min.			✓		
HoldUp 2"	2 7/8" Min.	9" Max.	9 3/4" Max.	10 ★	1.5" Min.				✓	✓
HoldUp EVO 1.25"	3" Min.	5" Max.	8 1/2" Max.	10 ★	2.375" Min.			✓		
HoldUp EVO 2"	3" Min.	5" Max.	8 1/2" Max.	10 ★	1.5" Min.				✓	✓
SingleSpeed™	1 5/8" Min.	7 3/4" Max	12" Max.	10 ★	2.75" Min.		◆	✓	✓	✓
FullSwing™	3" Min.	8 3/4" Max.	6 3/4" Max.	10 ★	1.5" Min.				✓	✓
SwingDaddy™	3" Min.	6 1/2" Max.	6 3/4" Max.	10 ★	1.5" Min.				✓	✓
FourTimer™	2 3/4" Min.	13 3/8" Max.	14 1/2" Max.	10 ★	1.5" Min.				✓	✓
TwoTimer™	1 7/8" Min.	12 1/2" Max.	12 1/2" Max.	10 ★	2" Min.		◆	✓	✓	✓
FullTilt™ 4/5	1 3/8" Min.	9 1/2" Max.	9 3/4" Max.	10 ★	2.5" Min.		◆	✓	✓	✓
LongHaul™	3 1/8" Min.	4 3/8" Max.	4 1/2" Max.	10 ★	1.5" Min.	✓			✓	✓
RoadTrip™	2 7/8" Min.	4 3/8" Max.	10 1/4" Max.	10 ★	1.5" Min.				✓	✓
RidgeBack™ 2/4/5	1 3/8" / 2 3/4" Min.	9.25" / 8" Max.	10" Max.	10 ★	1.5" Min.		◆		✓	✓
LiteRider™ 2/3	2 3/4" Min.	9" Max.	9" Max.	10 ★	2.75" Min.		◆	✓	✓	✓
DoubleDown™	2" Min.	9 1/8" Max.	9" Max.	10 ★	2" Min.		◆	✓	✓	✓
StageTwo™ 1.25"	2 3/4" Min.	6 1/4" Max.	8 1/2" Max.	10 ★	1.5" Min.				✓	✓
StageTwo™ 2"	3" Min.	5 3/8" Max.	8 1/2" Max.	10 ★	1.5" Min.	✓ (60lbs./bike)			✓	✓
HangTight™ 6	3" Min.	8" Max.	13" Max.	12" Min.	1.5" Min.				✓	✓
HangTight™ 4	3" Min.	8" Max.	13" Max.	10" Min.	1.5" Min.				✓	✓

★ Measurement D is a recommended minimum on this product. Using Yakima hitch mounted bike racks on vehicles with a pinhole to ground distance less than the minimum recommended increases the risk of the bikes or rack striking the ground while in use.

◆ Due to variations in Class I hitch receivers, some Class I receivers may not be able to accept this product. Please refer to Fit measurement "A" to see if this product will work on your class I.

Attention: Receiver hitches vary in capacity. Please insure you check your vehicles owners manual for tongue weight capacity prior to installing and using a hitch mounted carrier. Your vehicle's capacity must align with the Class requirements as stated in this table.