

YAKIMA Sprocket Rocket US

Type of Rack	Load	Min. - Max. Crossbar Spread*	Limits
 Round Bar & Square Bar	1 or 2 bikes	16" - 46" 41cm - 117cm	16" (41cm) spread = 30 lbs. (14kg)/bike
	3 or more bikes	18" - 46" 46cm - 117cm	35 lbs. (16kg)/bike

***CROSSBAR SPREAD**

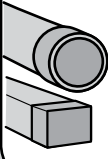
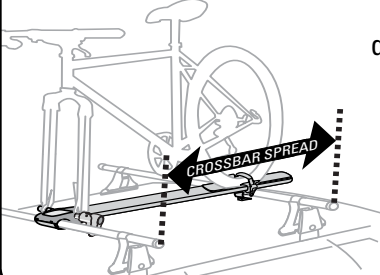

Your *crossbar spread* is the distance between the crossbars.

DO NOT EXCEED RACK WEIGHT LIMITS!



DESIGNED FOR FORKS WITH SAFETY TABS.

OFF-ROAD DRIVING IS NOT RECOMMENDED.

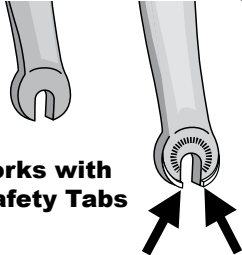

Forks with Safety Tabs

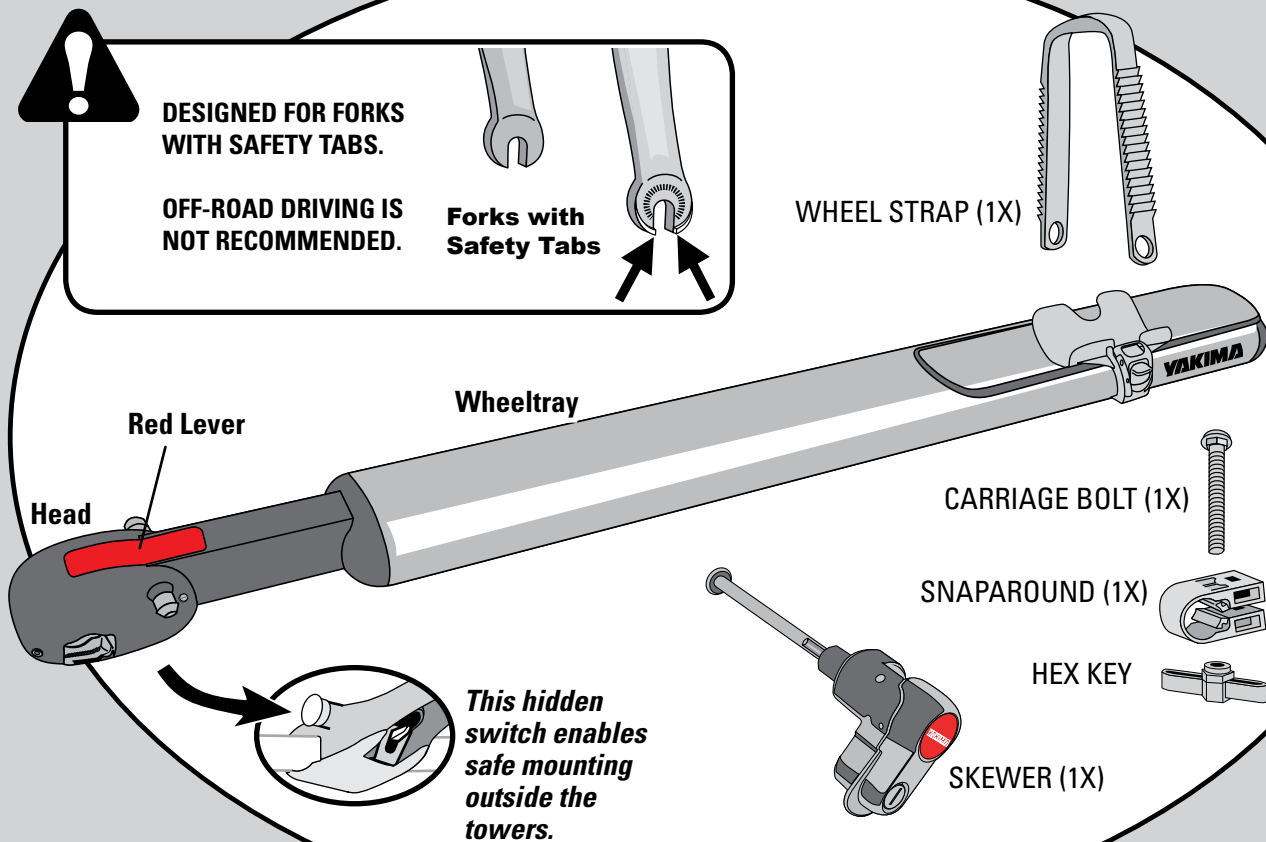

WHEEL STRAP (1X)

CARRIAGE BOLT (1X)

SNAPAROUND (1X)

HEX KEY

SKEWER (1X)

Red Lever

Head

Wheeltray

YAKIMA

This hidden switch enables safe mounting outside the towers.



IMPORTANT WARNING

IT IS CRITICAL THAT ALL YAKIMA RACKS AND ACCESSORIES BE PROPERLY AND SECURELY ATTACHED TO YOUR VEHICLE. IMPROPER ATTACHMENT COULD RESULT IN AN AUTOMOBILE ACCIDENT, AND COULD CAUSE SERIOUS BODILY INJURY OR DEATH TO YOU OR TO OTHERS. YOU ARE RESPONSIBLE FOR SECURING THE RACKS AND ACCESSORIES TO YOUR CAR, CHECKING THE ATTACHMENTS PRIOR TO USE, AND PERIODICALLY INSPECTING THE PRODUCTS FOR ADJUSTMENT, WEAR, AND DAMAGE. THEREFORE, YOU MUST READ AND UNDERSTAND ALL OF THE INSTRUCTIONS AND CAUTIONS SUPPLIED WITH YOUR YAKIMA PRODUCT PRIOR TO INSTALLATION OR USE. IF YOU DO NOT UNDERSTAND ALL OF THE INSTRUCTIONS AND CAUTIONS, OR IF YOU HAVE NO MECHANICAL EXPERIENCE AND ARE NOT THOROUGHLY FAMILIAR WITH THE INSTALLATION PROCEDURES, YOU SHOULD HAVE THE PRODUCT INSTALLED BY A PROFESSIONAL INSTALLER.

Part #1033352 Rev.F

1 DECIDE WHERE TO POSITION SPROCKET ROCKET.

BETWEEN TOWERS

SprocketRocket can slide along the crossbar for **easy repositioning**, even when locked and loaded.

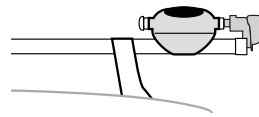
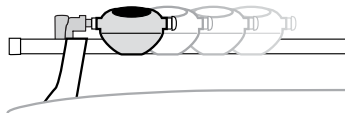

OUTSIDE TOWERS

SprocketRocket is in a **fixed location** for optimum security when mounted outside the towers.

2 ATTACH SNAPAROUND TO REAR CROSSBAR.

ROUND BARS

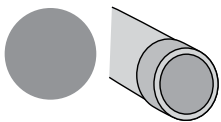

Attach SnapAround to rear crossbar.

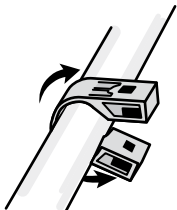

OR

SQUARE BARS

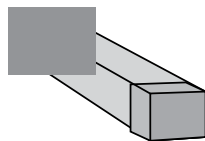

Loosen tabs by bending them back and forth.

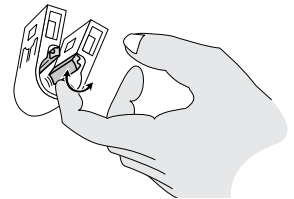

Remove tabs with scissors or pliers.

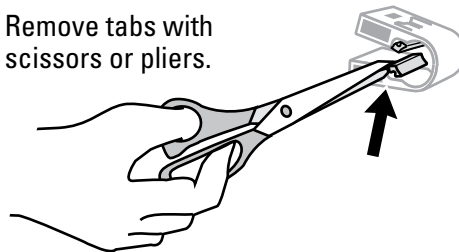

Attach SnapAround to rear crossbar.

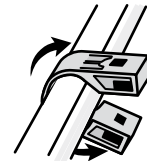

3 SECURE SPROCKET ROCKET TO CROSSBAR.

Press and lift red lever.

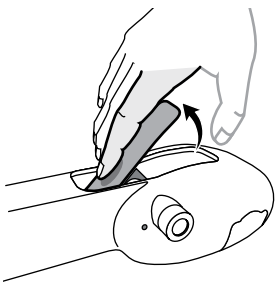

Jaw should drop open and silver hook should drop down.

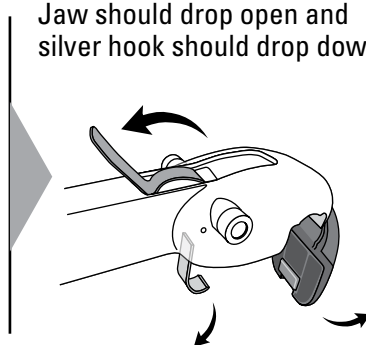

4 Set opened jaws onto crossbar. Slide head back until bar slips into mouth.

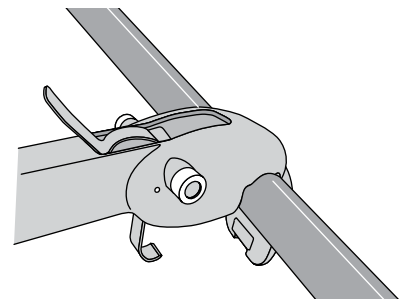

5 SECURE END OF WHEELTRAY TO CROSSBAR.

Slide wheeltray bolt into end of wheeltray.

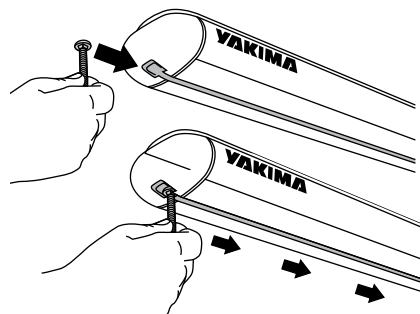

6 Align bolt to SnapAround. Push bolt through hole.

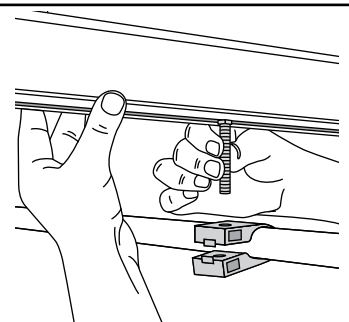

7 Close jaw, then press silver hook to close against jaw.

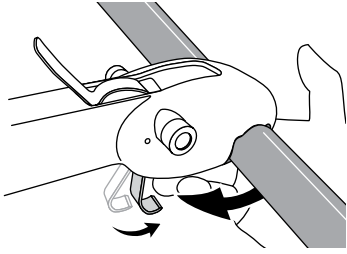

8 Close red lever.

COVER SHOULD CLOSE WITH FIRM RESISTANCE.

If not, repeat previous step, being sure to press the silver hook closed against jaw.

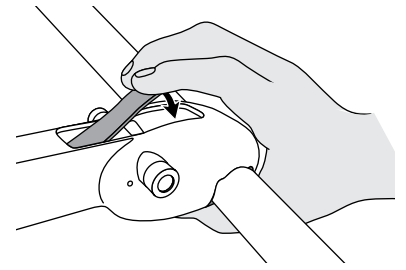

9 Attach Hex key and Tighten.

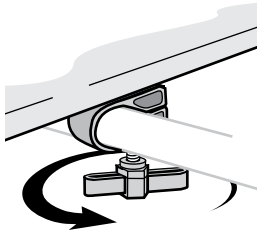

10 SEPARATE SKEWER FROM QUICK RELEASE LEVER.

Lift cover.

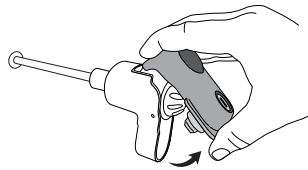

Loosen red knob until skewer slips out.

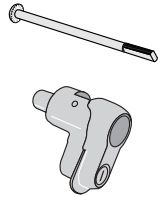
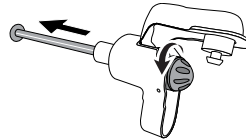

11 DETERMINE SWITCH POSITION AND INSERT SKEWER.
Switch is underneath SprocketRocket's head.

IF YOUR SPROCKETROCKET IS:

BETWEEN TOWERS

Skewer may be inserted from either side.
Consider access to red knob.

While holding the switch in the **DOWN** POSITION, insert the skewer.

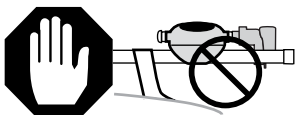
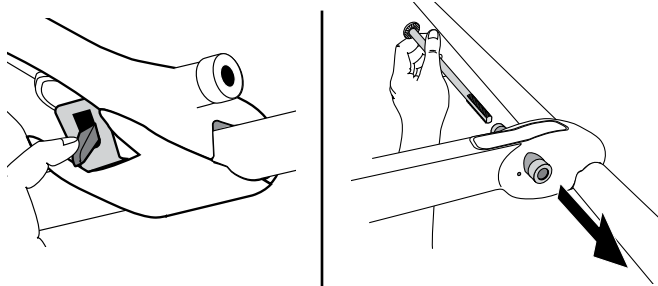

DO NOT INSTALL the SprocketRocket **OUTSIDE** the tower if the switch is in the **DOWN** position.

IF YOUR SPROCKETROCKET IS:

OUTSIDE TOWER

Skewer may be inserted from either side.
Consider access to red knob.

While holding the switch in the **UP** POSITION, insert the skewer.

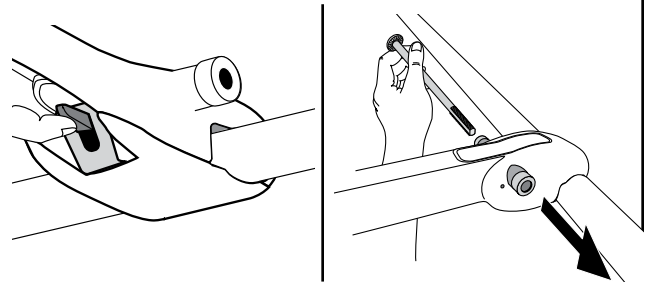

ALWAYS INSTALL THE SPROCKETROCKET OUTSIDE THE TOWER WITH THE SWITCH IN THE UP POSITION.



The red cover cannot be opened unless the skewer is unlocked and removed from the SprocketRocket's head.

12 ATTACH QUICK RELEASE LEVER.

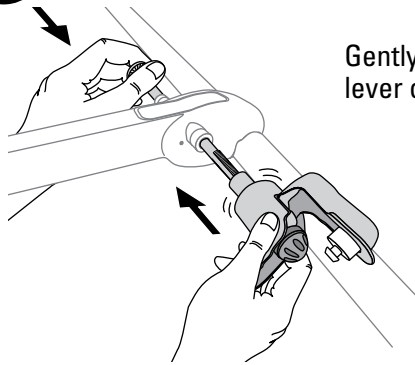

Gently push and wiggle lever onto skewer.

13

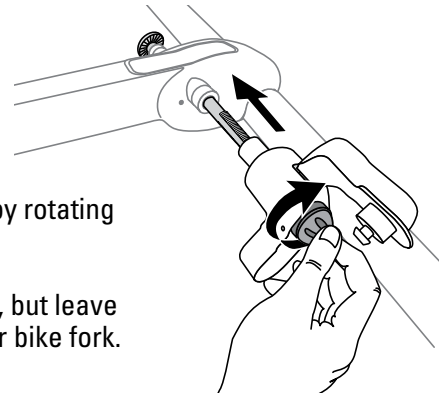

Engage skewer by rotating red knob.

Tighten red knob, but leave enough space for bike fork.

14 REMOVE FRONT WHEEL AND LOAD BIKE.

Set bicycle forks vertically onto skewer.

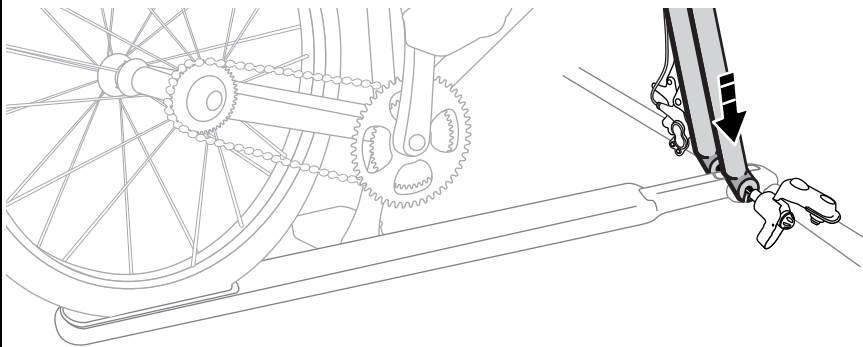

Prevent damage to your forks!

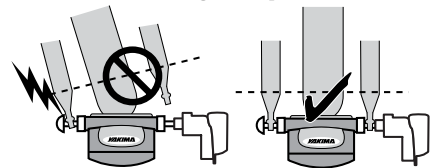

Use extra caution when installing, or removing bikes with **CARBON FIBER FORKS**. Fork tips can crack, or bend if bike is not loaded vertically.

15 CLOSE COVER.



Adjust red knob.
COVER SHOULD CLOSE WITH FIRM RESISTANCE.

- If not, tighten red knob and close cover again.
- If too much resistance, loosen red knob and try closing cover again.

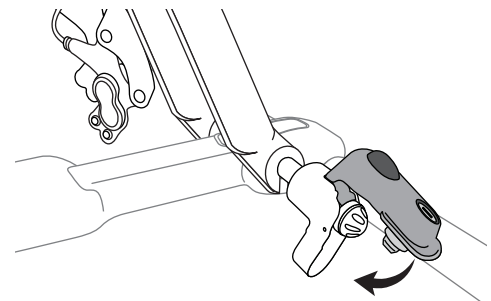

16 CHECK TO MAKE SURE BIKE FORK IS SECURE.

Tug on bike fork.

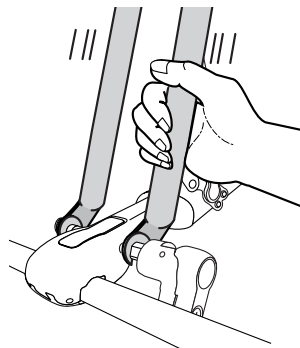

If forks move out of the skewer:

- Open cover, loosen red knob until forks slip onto skewer. Tighten red knob, close cover.
- Cover should close with **firm resistance** against forks.

17 LOCK QUICK RELEASE LEVER.

If you have purchased a lock, follow lock core instructions to install the lock.

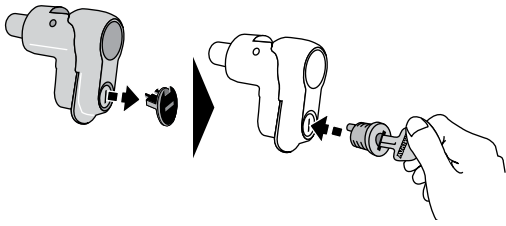

18 ATTACH WHEELSTRAP.

- Insert one end of strap into slot on far side of Wheeltray.
- Leave other end free.

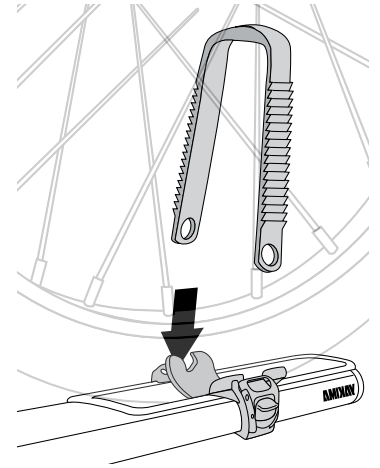

19 SECURE REAR WHEEL.

Pull strap through wheel spokes.

Do not let strap push against valve stem.

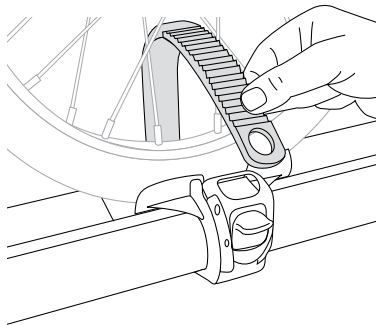

20 Insert strap end behind buckle.

TIGHTEN strap by repeatedly lifting buckle.

DO NOT OVERTIGHTEN STRAP!

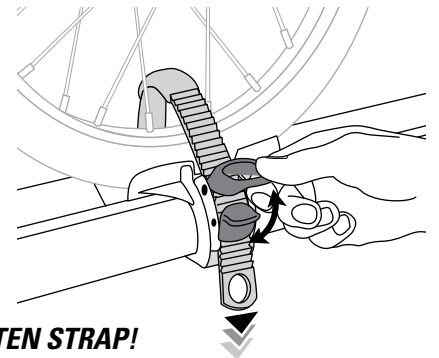

21 CHECK TIRE FOR TIGHT FIT.

- If not tight, loosen strap.
- Adjust position of strap and strap base until strap rests against rim.
- **TIGHTEN** strap again.

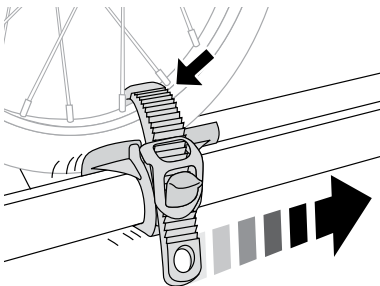

Keep strap centered on small wheels.

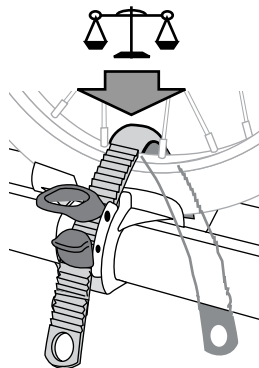

22 TO RELEASE STRAP:

Lift tab, lift up on strap.

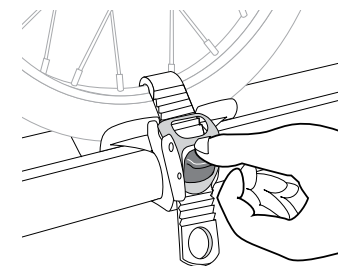

23 TO REPOSITION WHEN LOCKED AND/OR LOADED:

- Lift red lever, loosen hex key.
- Reposition SprocketRocket.
- Tighten hex key, close red lever.

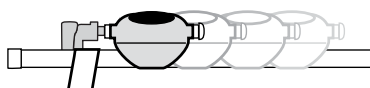

CAUTION

The red lever is spring-loaded and can pinch your fingers when opening. Use both hands as pictured to avoid a potential pinch.

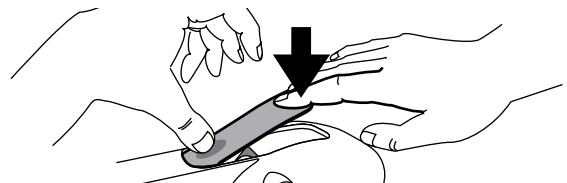

BEFORE DRIVING AWAY

CHECK REAR WHEEL.

Tighten the strap if needed.

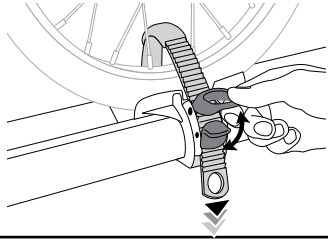

CHECK THAT BIKE FORK IS SECURE.

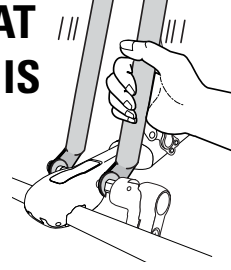

CHECK HEX KEY.

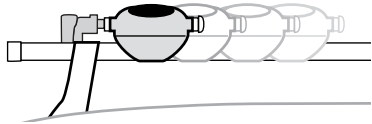
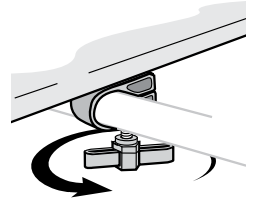

If mounted between towers and has been repositioned along the crossbar:

- ✓ close red lever
- ✓ tighten hex key

THE DRIVE:

- Do not transport bicycles with attached baby seats, panniers, wheel covers, full bike covers or motors.
- Do not carry tandem or recumbent bicycles.
- Off-road driving is not recommended and could result in damage to your vehicle or your bike.

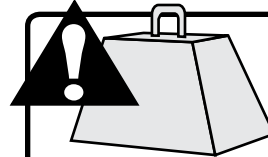

LOAD LIMIT

35 LBS. (16KG) PER BIKE

16" (41CM) CROSSBAR SPREADS =
30 LBS. (14KG) PER BIKE

IF YOU REMOVE CARRIER, FOLLOW INSTRUCTIONS TO REINSTALL.

**FOLLOW SAFETY
CHECKS AFTER EVERY
INSTALLATION.**

REAR HATCH ALWAYS USE CAUTION WHEN OPENING YOUR HATCH.

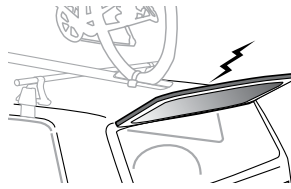

MAINTENANCE

Use non-water soluble lubricant on screws. Use a soft cloth with water and mild detergent to clean plastic parts.

**REMOVE BEFORE
ENTERING AN AUTOMATIC
CAR WASH.**



WARNING: BE SURE ALL HARDWARE IS SECURED ACCORDING TO INSTRUCTIONS. ATTACHMENT HARDWARE CAN LOOSEN OVER TIME. CHECK BEFORE EACH USE, AND TIGHTEN IF NECESSARY.

TECHNICAL ASSISTANCE OR REPLACEMENT PARTS

**CONTACT YOUR DEALER OR CALL
(888) 925-4621
MONDAY THROUGH FRIDAY,
7:00 AM TO 5:00 PM, PST**



This product is covered by YAKIMA's
"Love It Till You Leave It" Limited Lifetime Warranty
To obtain a copy of this warranty,
go online to www.yakima.com
or email us at yakwarranty@yakima.com
or call (888) 925-4621

KEEP THESE INSTRUCTIONS!

YAKIMA Sprocket Rocket

FR

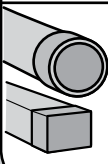
Type de porte-bagage	Charge	Distance mini - maxi entre barres transversales*	Limits
 Barres rondes ou carrées	1 ou 2 vélos	16" - 46" 41cm - 117cm	distance de 41cm (16") 14kg (30 lbs.)/vélo
	3 vélos ou plus	18" - 46" 46cm - 117cm	16 kg (35 lbs.)/vélo

NE PAS DÉPASSER LA LIMITE DE CHARGE DU PORTE-BAGAGE !

*DISTANCE ENTRE LES BARRES TRANSVERSALES

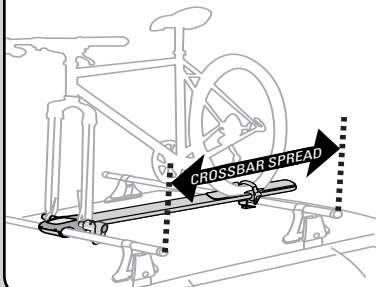

La distance entre les barres transversales c'est... la distance entre les barres transversales !



CONÇU POUR LES FOURCHES MUNIES D'ERGOTS DE SÉCURITÉ. LA CONDUITE HORS-ROUTE N'EST PAS RECOMMANDÉE.

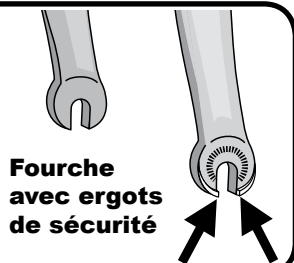

Fourche avec ergots de sécurité

SANGLE DE ROUE (X1)

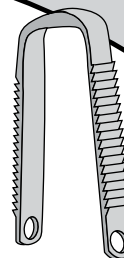

Profilé

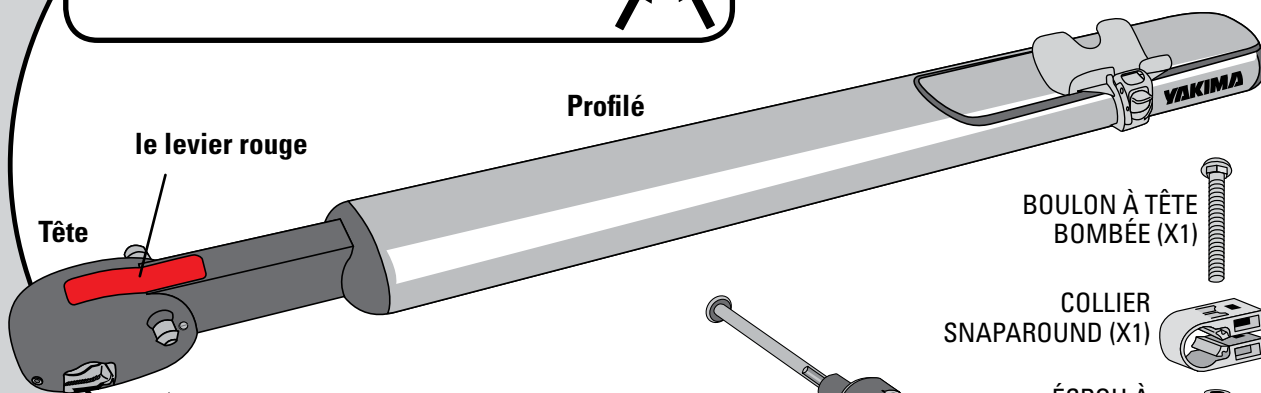

le levier rouge

Tête

BOULON À TÊTE BOMBÉE (X1)



COLLIER SNAPAROUND (X1)



ÉCROU À AILETTES (X1)

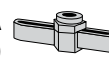

Ce levier caché permet de monter le porte-vélo solidement à l'extérieur des pieds.

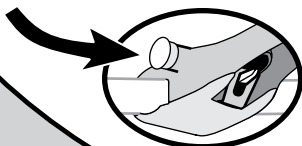

AXE À SERRAGE RAPIDE VERROUILLABLE (X 1)

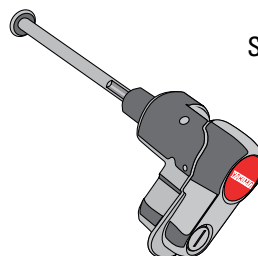

AVERTISSEMENT IMPORTANT

IL EST IMPÉRATIF QUE LES PORTE-BAGAGES ET LES ACCESSOIRES YAKIMA SOIENT CORRECTEMENT ET SOLIDEMENT FIXÉS AU VÉHICULE. UN MONTAGE MAL RÉALISÉ POURRAIT PROVOQUER UN ACCIDENT D'AUTOMOBILE, QUI POURRAIT ENTRAÎNER DES BLESSURES GRAVES OU MÊME LA MORT, À VOUS OU À D'AUTRES PERSONNES. VOUS ÊTES RESPONSABLE DE L'INSTALLATION DU PORTE-BAGAGES ET DES ACCESSOIRES SUR VOTRE VÉHICULE, D'EN VÉRIFIER LA SOLIDITÉ AVANT DE PRENDRE LA ROUTE ET DE LES INSPECTER RÉGULIÈREMENT POUR EN CONTRÔLER L'ÉTAT, L'AJUSTEMENT ET L'USURE. VOUS DEVEZ DONC LIRE ATTENTIVEMENT TOUTES LES INSTRUCTIONS ET TOUS LES AVERTISSEMENTS ACCOMPAGNANT VOTRE PRODUIT YAKIMA AVANT DE L'INSTALLER ET DE L'UTILISER. SI VOUS NE COMPRENEZ PAS TOUTES LES INSTRUCTIONS ET TOUS LES AVERTISSEMENTS, OU SI VOUS N'AVEZ PAS DE COMPÉTENCES EN MÉCANIQUE ET NE COMPRENEZ PAS PARFAITEMENT LA MÉTHODE DE MONTAGE, VOUS DEVRIEZ FAIRE INSTALLER LE PRODUIT PAR UN PROFESSIONNEL, COMME UN MÉCANICIEN OU UN CARROSSIER COMPÉTENT.

1 DÉCIDER OÙ L'ON VEUT PLACER LE PORTE-VÉLO.

ENTRE LES PIEDS

On peut facilement repositionner le porte-vélo SprocketRocket le long des barres en le faisant coulisser, même s'il est verrouillé et chargé.

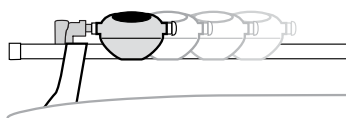

À L'EXTÉRIEUR DES PIEDS

On peut monter le porte-vélo SprocketRocket en position fixe, pour un maximum de sécurité à l'extérieur des pieds.

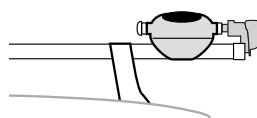

2 POSER LE COLLIER SNAPAROUND SUR LA BARRE TRANSVERSALE ARRIÈRE.

BARRES RONDES

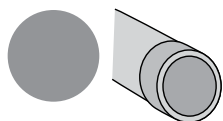

Enfiler le collier SnapAround sur la barre arrière.

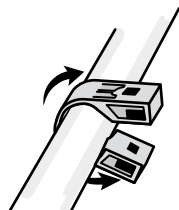

OU

BARRES CARRÉES

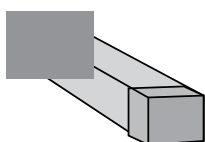

Assouplir les cales en les pliant plusieurs fois.

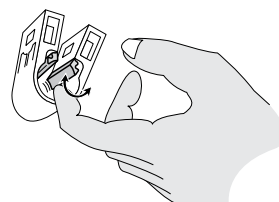

Enlever les cales avec des ciseaux ou des pinces.

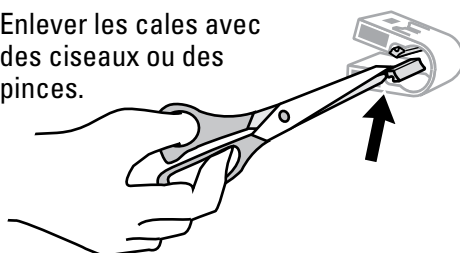

Enfiler le collier SnapAround sur la barre arrière.

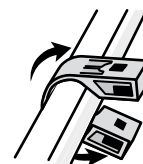

3 FIXER LE PORTE-VÉLO SUR LA BARRE TRANSVERSALE.

Appuyer et relever le levier rouge.

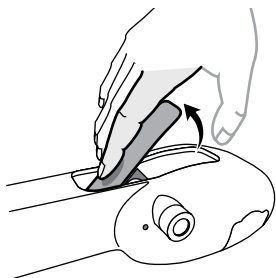

La mâchoire devrait s'ouvrir vers le bas et le crochet argenté devrait descendre.

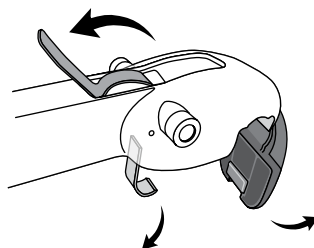

4

Déposer la mâchoire ouverte sur la barre. Glisser la tête vers l'arrière de manière que la barre s'engage dans son logement.

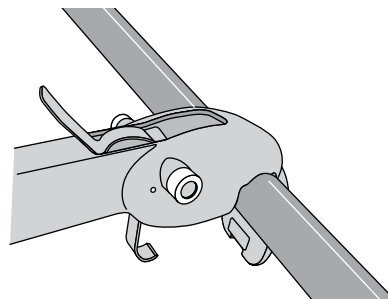

5 FIXER LE BOUT DU PROFILÉ À LA BARRE TRANSVERSALE.

Enfiler le boulon dans l'arrière du profilé.

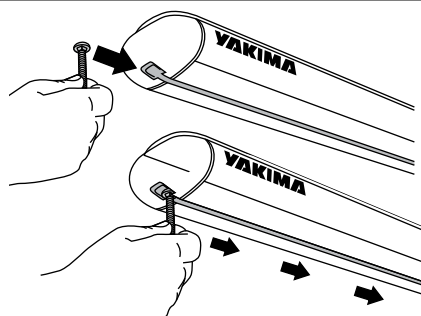

6

Aligner le boulon avec le trou du collier et l'engager.

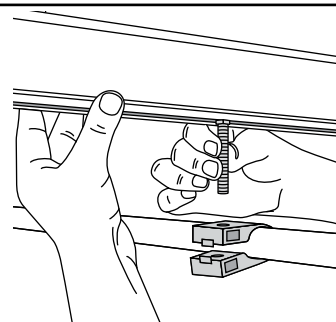

7

Refermer la mâchoire, puis rabattre le crochet argenté contre la mâchoire.

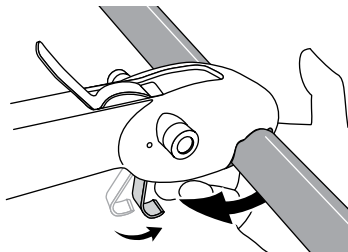
**8**

Rabattre le levier rouge.

IL DEVRAIT SE FERMER AVEC UNE BONNE RÉSISTANCE.

Si ce n'est pas le cas, reprendre l'opération précédente, en veillant à appuyer sur le crochet argenté contre la mâchoire.

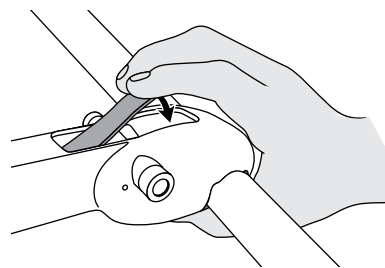
**9**

Poser l'écrou à ailettes et le serrer.

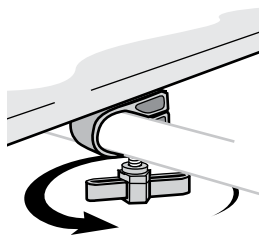
**10**

SÉPARER L'AXE DU LEVIER DE SERRAGE RAPIDE.

Relever le couvercle.

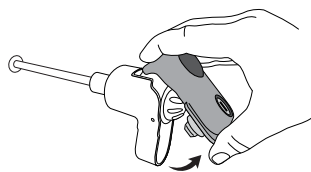

Desserrer le bouton rouge jusqu'à ce que l'axe sorte.

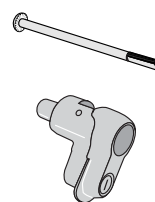
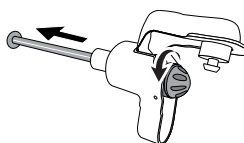
**11**

DÉTERMINER LA POSITION DU COMMUTATEUR ET ENFILER L'AXE.

Le commutateur se trouve sous la tête du porte-vélo.

Si l'on monte le porte-vélo SprocketRocket :

ENTRE LES PIEDS

On peut enfiler l'axe d'un côté ou de l'autre (tenir compte de l'accès au bouton rouge).

En tenant le levier **EN BAS**, enfiler l'axe.

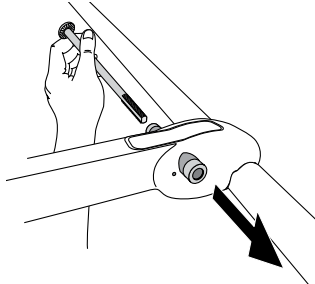
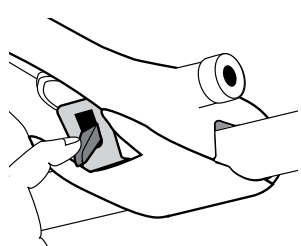

Si l'on monte le porte-vélo SprocketRocket :

À L'EXTÉRIEUR DES PIEDS

On peut enfiler l'axe d'un côté ou de l'autre (tenir compte de l'accès au bouton rouge).

En tenant le levier **EN HAUT**, enfiler l'axe.

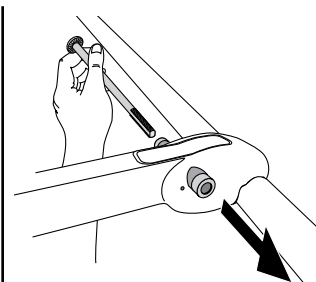
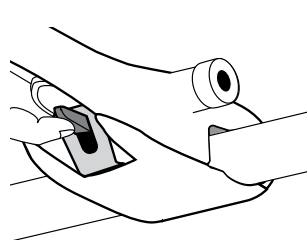

SI L'ON INSTALLE LE PORTE-VÉLO À L'EXTÉRIEUR DES PIEDS, LE LEVIER DOIT TOUJOURS ÊTRE EN HAUT.

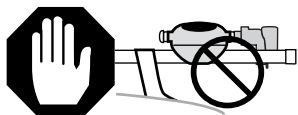

NE PAS INSTALLER le porte-vélo À L'EXTÉRIEUR des pieds si le levier est EN BAS.



Le levier rouge ne peut pas être relevé, à moins de déverrouiller l'axe et de le sortir de la tête du porte-vélo.

12 POSER LE LEVIER DE SERRAGE RAPIDE.

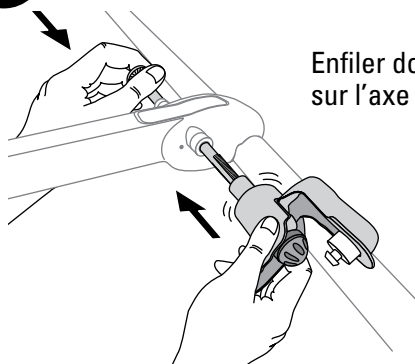

Enfiler doucement le boîtier sur l'axe en tournant.

13

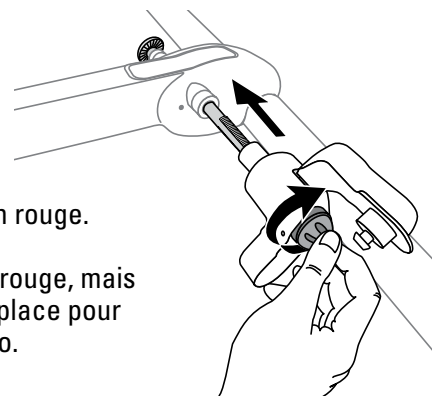

Tourner le bouton rouge.

Serrer le bouton rouge, mais laisser assez de place pour la fourche du vélo.

14 ENLEVER LA ROUE AVANT ET CHARGER LE VÉLO.

Déposer la fourche du vélo verticalement sur l'axe.

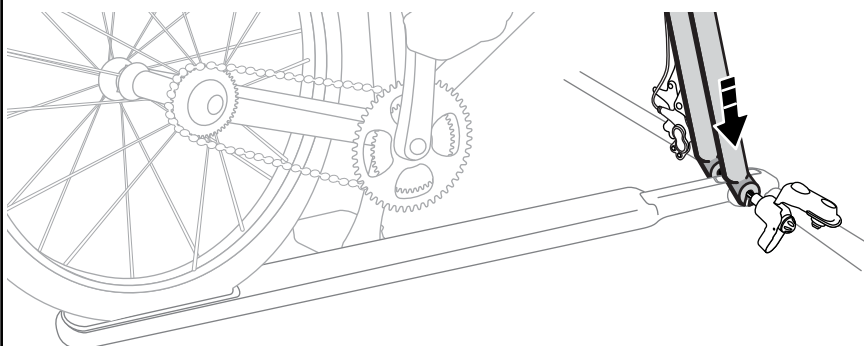

Attention de ne pas endommager la fourche!

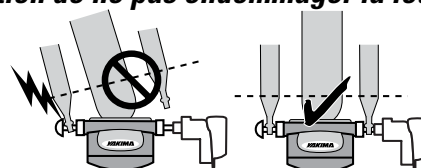

Faire particulièrement attention quand on charge ou décharge des vélos À FOURCHE EN FIBRE DE CARBONE. Les pattes de la fourche pourraient casser ou plier si le vélo n'est pas chargé verticalement.

15 RABATTRE LE LEVIER DE SERRAGE RAPIDE.

**RÉGLER LE BOUTON ROUGE...
LE LEVIER DOIT SE FERMER
AVEC UNE BONNE
RÉSISTANCE.**



- Si le levier se rabat trop facilement, serrer le bouton rouge et recommencer.
- Si le levier est trop dur, desserrer le bouton rouge et recommencer.

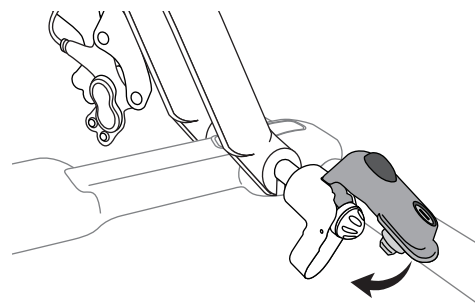

16 VÉRIFIER LA SOLIDITÉ DU MONTAGE DE LA FOURCHE.

Tirer sur un des bras de fourche.

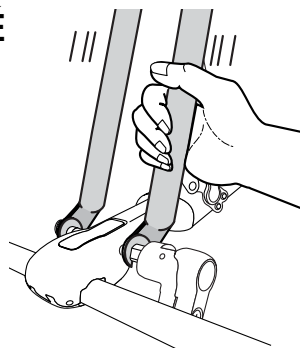

Si la fourche se libère de l'axe à serrage rapide :

- Ouvrir le levier, desserrer le bouton rouge jusqu'à ce que la fourche s'engage sur l'axe. Serrer le bouton rouge légèrement et refermer le levier.
- Le levier doit se fermer **avec une bonne résistance** contre la fourche.

17 VERROUILLER L'AXE.

Si l'on a acheté une serrure, suivre les instructions qui l'accompagnent pour l'installer.

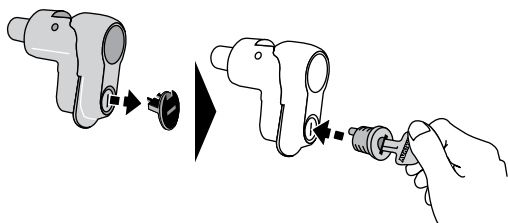

18 INSTALLER LA SANGLE DE ROUE.

- Enfiler un bout de la sangle dans la fente du côté du profilé opposé à soi.
- Laisser l'autre bout libre.

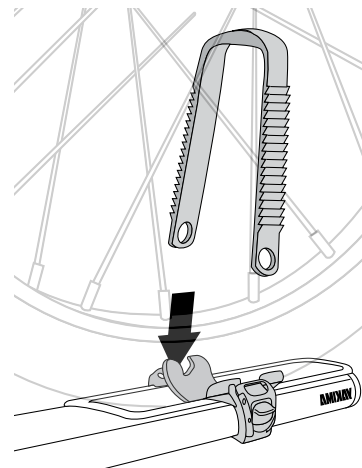

19 IMMOBILISER LA ROUE ARRIÈRE.

Passer la sangle entre les rayons.

Ne pas appuyer la sangle contre la tige de la valve.

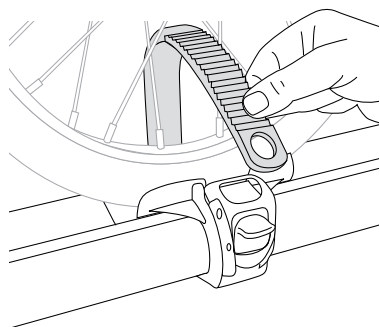

20 Glisser le bout de la sangle derrière le levier.

SERRER la sangle en relevant le levier plusieurs fois.

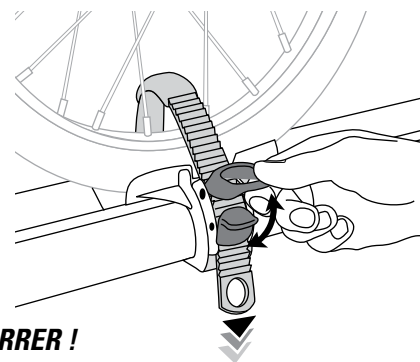

NE PAS TROP SERRER !

21 VÉRIFIER QUE LA ROUE EST BIEN RETENUE.

- Si la roue a du jeu, desserrer la sangle.
- Faire coulisser la sangle le long du profilé jusqu'à ce qu'elle porte contre la jante.
- **SERRER de nouveau.**

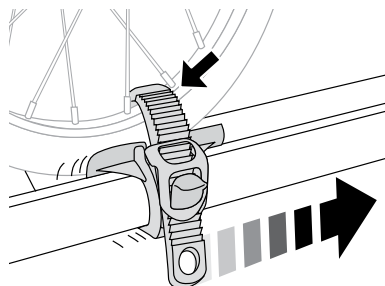

Si la roue est petite, garder la sangle centrée.

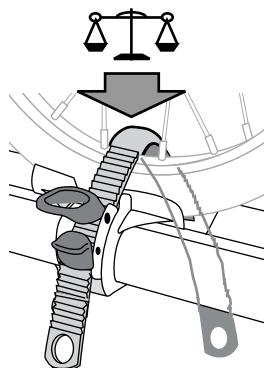

22 POUR LIBÉRER LA SANGLE ARRIÈRE :

Appuyer sur le bouton de la boucle et sortir la sangle.

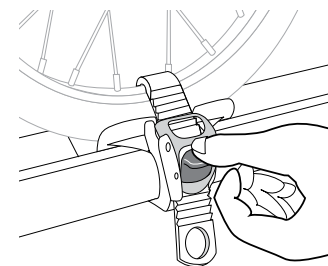

23 POUR DÉPLACER LE PORTE-VÉLO UNE FOIS VERROUILLÉ OU CHARGÉ :

- Relever le levier rouge, desserrer l'écrou à ailettes.
- Déplacer le porte-vélo.
- Serrer l'écrou à ailettes et le couvercle rouge.

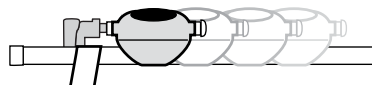

ATTENTION

Le levier rouge est monté sur ressort et pourrait pincer les doigts au moment de l'ouverture. Employer les deux mains, tel qu'illustré, pour éviter ce risque.

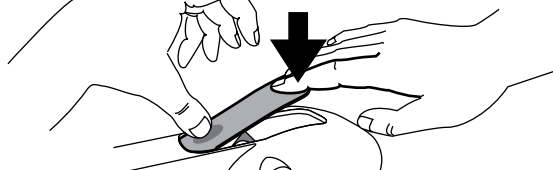

AVANT DE PRENDRE LA ROUTE

VÉRIFIER LA ROUE ARRIÈRE

Serrer la sangle au besoin.

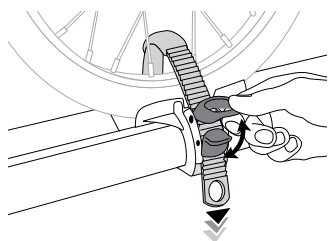

VÉRIFIER LA SOLIDITÉ DU MONTAGE DE LA FOURCHE.

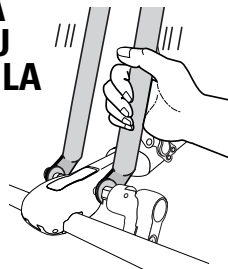

VÉRIFIER L'ÉCROU À AILETTES.

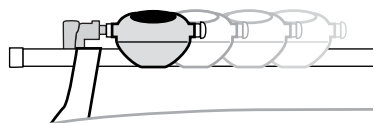
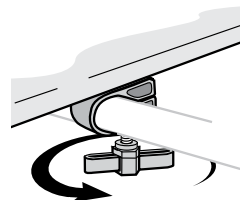

Si le porte-vélo est monté entre les pieds du porte-bagages et a été déplacé le long des barres :

- ✓ *rabattre le levier rouge*
- ✓ *serrer l'écrou à ailettes*

EN COURS D'UTILISATION

- Ne pas transporter de bicyclettes munies d'un siège de bébé, de sacoches, de housses de roues, de housses de vélo complètes ou de moteur.
- Ne pas employer pour le transport de tandems ou de vélos surbaissés.
- La conduite hors route n'est pas recommandée : cela pourrait endommager le véhicule ou le vélo.



LIMIT DE CHARGEMENT

16 kg (35 lbs.)/vélo

distance de 41cm (16") = 14kg (30 lbs.)/vélo

SI L'ON ENLÈVE LE PORTE-VÉLO, SUIVRE LES INSTRUCTIONS POUR LE REMETTRE EN PLACE.
Effectuer les vérifications de sécurité après toute réinstallation.

HAYON TOUJOURS OUVRIR LE HAYON AVEC PRUDENCE.

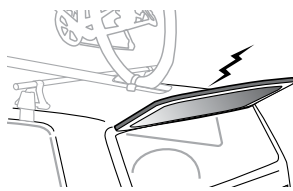

ENTRETIEN: Lubrifier les boulons avec un lubrifiant non soluble à l'eau. Nettoyer les pièces en plastique avec un chiffon, de l'eau et un savon doux.

ENLEVER LE PORTE-VÉLO AVANT DE PASSER DANS UN LAVE-AUTO AUTOMATIQUE.



AVERTISSEMENT: S'ASSURER QUE LE MONTAGE EST SOLIDE ET CONFORME AUX INSTRUCTIONS. LES DISPOSITIFS DE FIXATION PEUVENT SE DESSERRER À LA LONGUE. LES INSPECTER AVANT CHAQUE UTILISATION ET LES RESSERRER AU BESOIN.

RENSEIGNEMENTS TECHNIQUES COMPLÉMENTAIRES OU DE PIÈCES DE RECHANGE



Prière de contacter votre dépositaire ou appelez-nous au (888) 925-4621 du lundi au vendredi, entre 7 heures et 17 heures, heure du Pacifique.



Ce produit est couvert par YAKIMA Garantie à vie limitée «Tant que durera notre histoire d'amour» Pour obtenir une copie de cette garantie, aller en ligne à www.yakima.com, ou nous envoie un e-mail à yakwarranty@yakima.com ou l'appel (888) 925-4621

CONSERVER CES INSTRUCTIONS!

YAKIMA Sprocket Rocket ES

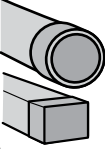
Tipo de portabicicleta	 Carga	Separación entre travesaños mín. - máx.*	 Límites
 Barra redonda y barra cuadrada	1 o 2 bicicletas	16" - 46" 41cm - 117cm	Separación de 16" (41cm) = 14kg (30 lbs.)/bicicleta
	3 o más bicicletas	18" - 46" 46cm - 117cm	16 kg (35 lbs.)/bicicleta

¡NO EXCEDA LOS LÍMITES DE CARGA DEL PORTABICICLETA!

***SEPARACIÓN ENTRE TRAVESAÑOS**

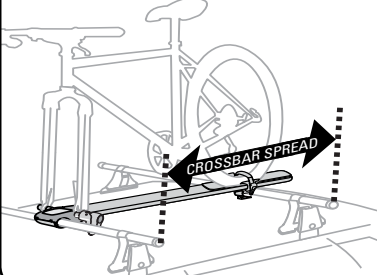

La separación entre travesaños es la distancia entre las barras transversales.



DISEÑADO PARA HORQUILLAS CON OREJETAS DE SEGURIDAD. NO SE RECOMIENDA CONDUCIR FUERA DE LA RUTA.

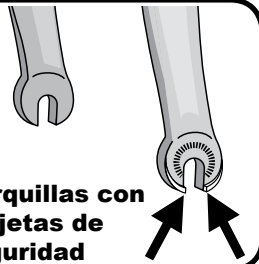

Horquillas con orejetas de seguridad

CORREA PARA RUEDA (1X)

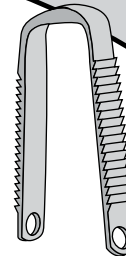

Riel para rueda

TORNILLO CABEZA DE HONGO (1X)

SNAPAROUND (1X)

TUERCA HEXAGONAL (1X)

BROQUETA DE BLOQUEO (1X)

palanca roja
Cabeza

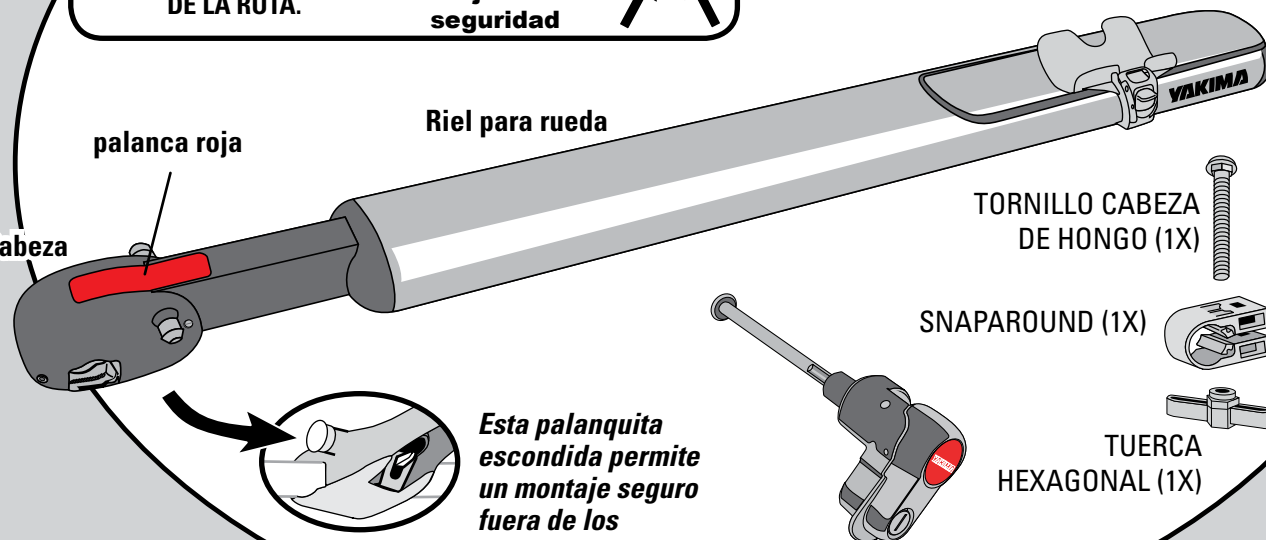

Esta palanquita escondida permite un montaje seguro fuera de los soportes.



AVISO IMPORTANTE:

ES FUNDAMENTAL QUE TODAS LAS PARRILLAS Y ACCESORIOS YAKIMA ESTÉN BIEN COLOCADOS Y ASEGURADOS AL VEHÍCULO. UNA INSTALACIÓN DEFICIENTE PODRÍA RESULTAR EN ACCIDENTE AUTOMOVILÍSTICO Y PROVOCAR HERIDAS GRAVES O MUERTE A USTED O A TERCEROS. USTED ES RESPONSABLE DE ASEGURAR LAS PARRILLAS Y ACCESORIOS AL VEHÍCULO, VERIFICANDO UNIONES Y AMARRES ANTES DE USAR E INSPECCIONANDO EL AJUSTE DE LOS PRODUCTOS, SU DESGASTE Y POSIBLES DAÑOS. POR ELLO DEBE LEER Y COMPRENDER TODAS LAS INSTRUCCIONES Y ADVERTENCIAS QUE VIENEN CON LOS PRODUCTOS YAKIMA ANTES DE INSTALARLOS O USARLOS. SI NO ENTIENDE TODAS LAS INSTRUCCIONES Y ADVERTENCIAS, O NO TIENE EXPERIENCIA EN MECÁNICA O NO ESTÁ FAMILIARIZADO CON LOS PROCEDIMIENTOS DE INSTALACIÓN, HAGA INSTALAR EL PRODUCTO POR UN PROFESIONAL EN UN GARAGE CONOCIDO O EN UN TALLER DE CARROCERÍA.

1 DECIDA DÓNDE COLOCARÁ EL SPROCKETROCKET.

ENTRE SOPORTES

El SprocketRocket puede deslizarse por el travesaño para reubicarlo fácilmente aún si está trancado y cargado.

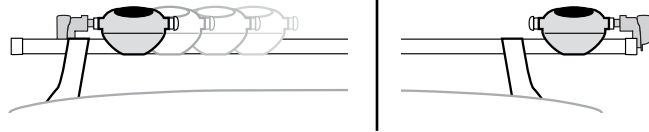

HACIA AFUERA DE LOS SOPORTES

El SprocketRocket está en posición fija para seguridad óptima cuando se instala hacia afuera de los soportes.

2 COLOQUE EL BROCHE SNAPAROUND EN EL TRAVESAÑO TRASERO.

TRAVESAÑOS REDONDOS

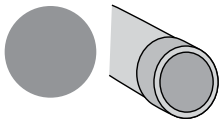

Coloque el SnapAround en el travesaño trasero.

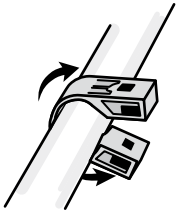

TRAVESAÑOS CUADRADOS

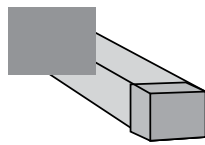

Aflove las orejuelas doblándolas repetidamente.

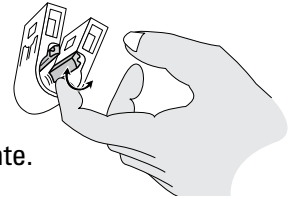

Quite las orejuelas con tijeras o pinzas.

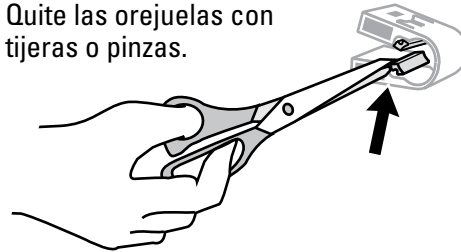

Coloque el SnapAround en el travesaño trasero.

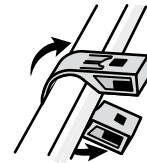

3 FIJE EL SPROCKETROCKET AL TRAVESAÑO.

Oprima y levante la palanca roja.

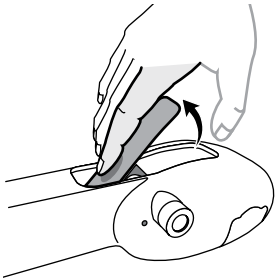

La mandíbula se abrirá y el gancho plateado bajará.

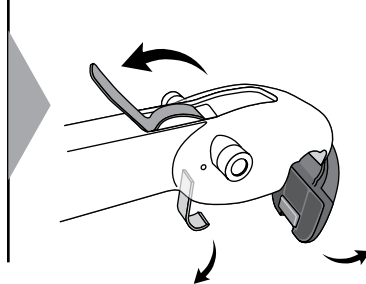

4 Coloque las mandíbulas abiertas sobre el travesaño. Deslice la cabeza hacia atrás hasta que el travesaño entre en la abertura.

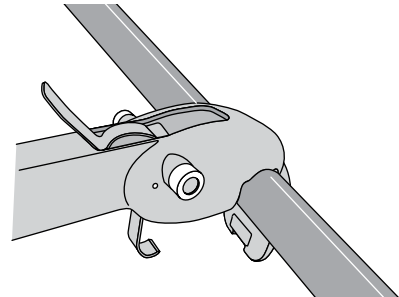

5 FIJE EL EXTREMO DEL RIEL AL TRAVESAÑO.

Inserte el tornillo en el extremo del riel para rueda.

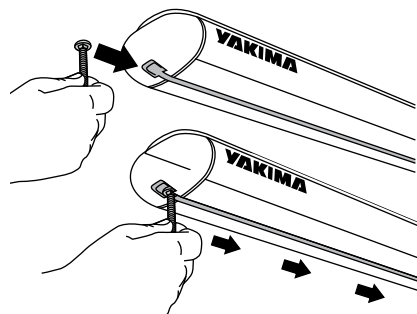

6

Haga corresponder el tornillo con el SnapAround. Insértelo en el agujero.

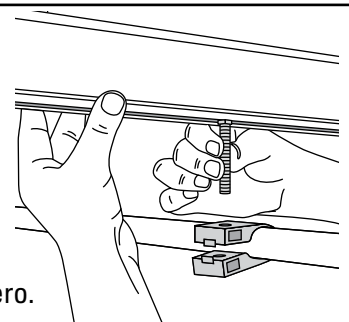

7 Cierre la mandíbula, luego oprima el gancho plateado para que cierre contra la mandíbula.

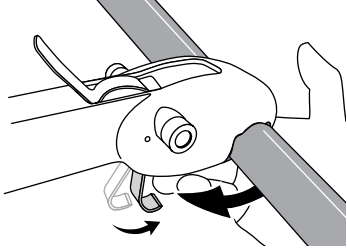

8 Cierre la palanca roja.

LA CUBIERTA DEBE CERRAR CON FIRME RESISTENCIA.

De no ser así, repita el paso anterior, cerciorándose de apretar el gancho plateado contra la mandíbula.

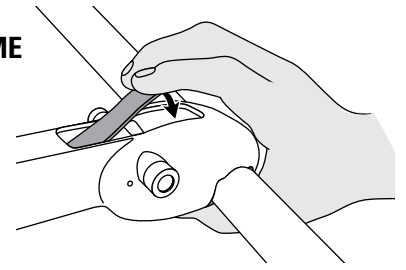

9 Coloque la tuerca hexagonal y ajuste.

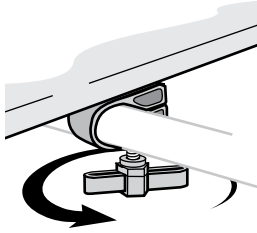

10 SEPARE LA BROQUETA DE LA PALANCA DE SUELTA RÁPIDA.

Levante la cubierta.

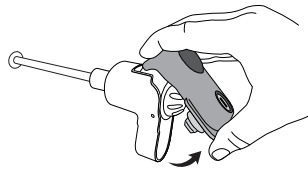

Afloje la perilla roja hasta que la broqueta salga.

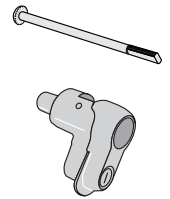
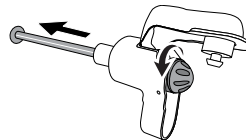

11 DETERMINE LA UBICACIÓN DE LA PALANQUITA E INSERTE LA BROQUETA.
La palanquita está debajo de la cabeza del SprocketRocket.

Si instaló:

ENTRE SOPORTES

La broqueta puede insertarse desde cualquier lado. Tenga en cuenta el acceso a la perilla roja.

Sosteniendo la palanquita HACIA ABAJO, inserte la broqueta.

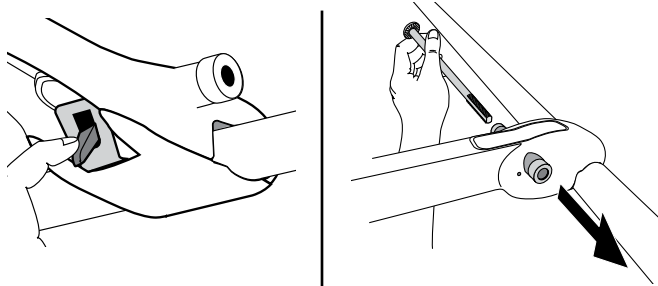

Si instaló:

HACIA AFUERA DE LOS SOPORTES

La broqueta puede insertarse desde cualquier lado. Tenga en cuenta el acceso a la perilla roja.

Sosteniendo la palanquita HACIA ARRIBA, inserte la broqueta.

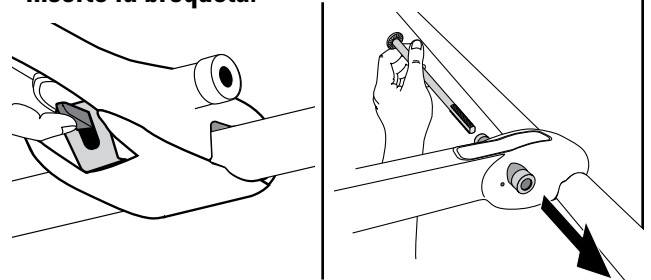

SIEMPRE INSTALE EL SPROCKETROCKET HACIA AFUERA DEL SOPORTE CON LA PALANQUITA HACIA ARRIBA.

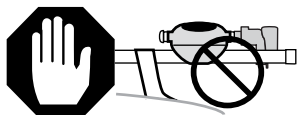

NO INSTALE el SprocketRocket HACIA AFUERA del soporte Si la palanquita está hacia abajo.



La cubierta roja no puede abrirse a menos que la broqueta esté suelta y fuera de la cabeza del SprocketRocket.

12 COLOQUE LA PALANCA DE SUELTA RÁPIDA.

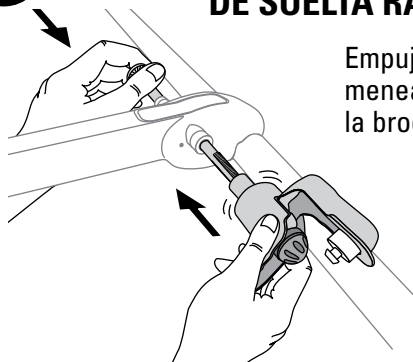

Empuje suavemente meneando la palanca en la broqueta.

13

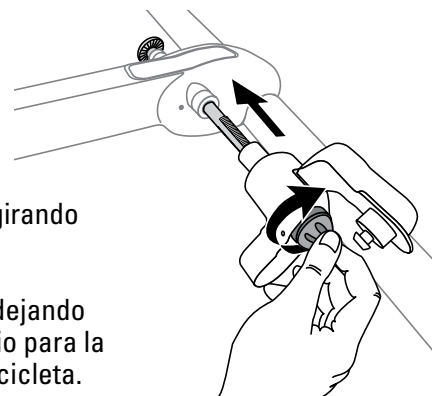

Fije la broqueta girando la perilla roja.

Ajuste la perilla dejando suficiente espacio para la horquilla de la bicicleta.

14 quite la rueda delantera y cargue la bicicleta.

Coloque las horquillas verticalmente sobre la broqueta.

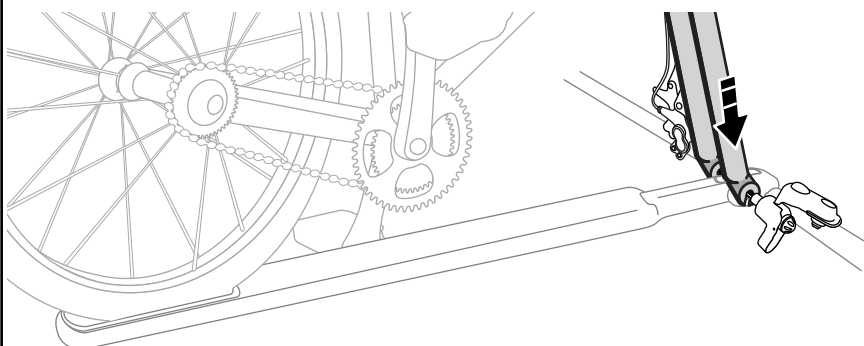

¡Evite dañar las horquillas!

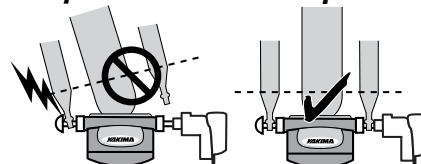

Ponga un cuidado especial al instalar o retirar las bicicletas que tienen HORQUILLAS DE FIBRA DE CARBONO. Los extremos de la horquilla se pueden agrietar o doblar si la bicicleta no se carga verticalmente.

15 CIERRE LA CUBIERTA.

AJUSTE LA PERILLA... LA CUBIERTA DEBE CERRAR CON FIRME RESISTENCIA.



- De no ser así, ajuste la perilla y cierre la cubierta de nuevo.
- Si hay demasiada resistencia, afloje la perilla y trate nuevamente.

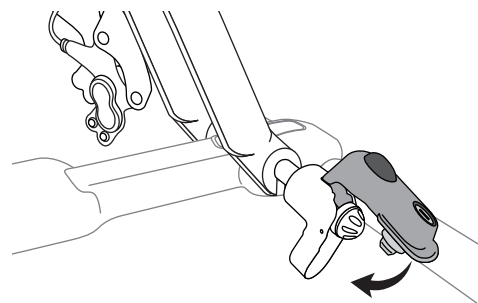

16 VERIFIQUE QUE LA HORQUILLA ESTÁ BIEN ASEGURADA.

Sacuda la horquilla.

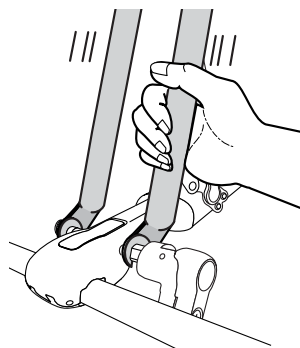

Si la horquilla se sale de la broqueta:

- Abra la cubierta, afloje la perilla roja hasta que la horquilla encaje en la broqueta. Ajuste la perilla y cierre la cubierta.
- La cubierta debe cerrar con firme resistencia contra la horquilla.

17 TRANQUE EL SPROCKETROCKET.

Si compró un cerrojo, siga las instrucciones para instalarlo.

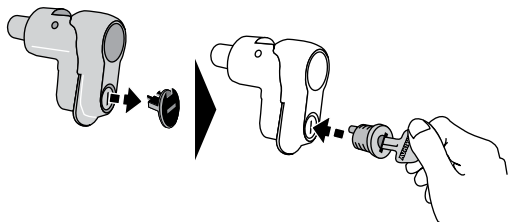

18 COLOQUE LA CORREA PARA RUEDA.

- Inserte un extremo de la correa en la ranura del lado alejado del riel.
- Deje libre el otro extremo.

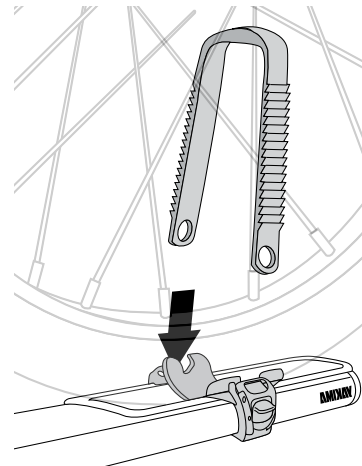

19 ASEGURE LA RUEDA TRASERA.

Pase la correa por entre los rayos de la rueda.

Evite que la correa oprima la válvula.

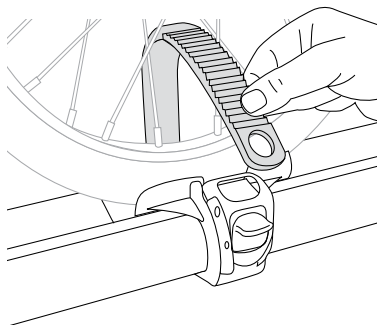

20 Inserte el extremo de la correa detrás de la hebilla.

AJUSTE la correa levantando repetidamente la hebilla.

¡NO AJUSTE DE MÁS LA CORREA!

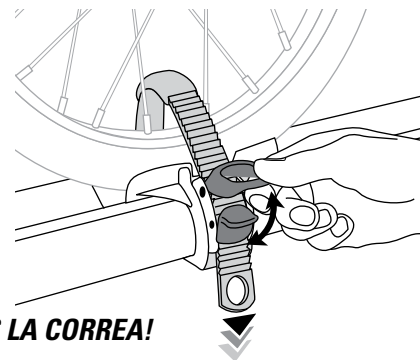

21 VERIFIQUE QUE EL NEUMÁTICO ESTA FIRME.

- Si no está firme, afloje la correa.
- Ajuste la posición de la correa y de su base hasta que la correa se apoye en la llanta.
- **AJUSTE nuevamente la correa.**

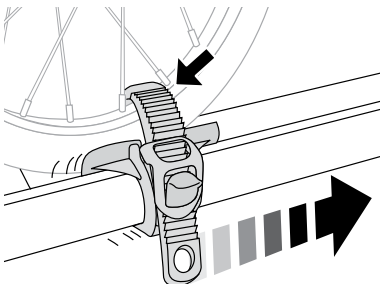

Mantega el centrado para ruedas pequeñas.

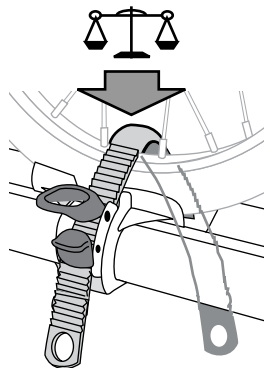

22 PARA SOLTAR LA CORREA:

Levante la orejuela, levante la correa.

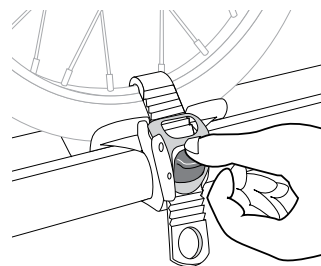

23 PARA REUBICAR EL PORTABICICLETAS CUANDO ESTE TRANCADO O CARGADO:

- Levante la palanca roja, afloje la tuerca hexagonal.
- Reubique el portabicicletas.
- Ajuste la tuerca hexagonal, cierre la palanca roja.

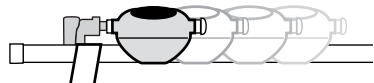

PRECAUCIÓN

La palanca roja tiene un mecanismo de resorte que puede presionar sus dedos cuando se desengancha. Se recomienda utilizar ambas manos, como se muestra en la ilustración, para evitar algún daño.

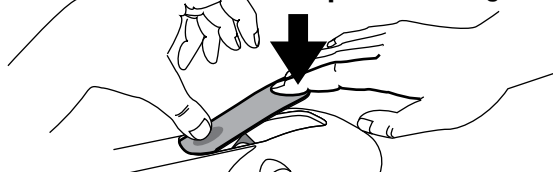

ANTES DE PARTIR

VERIFIQUE LA RUEDA TRASERA.

Ajuste la correa si es necesario.

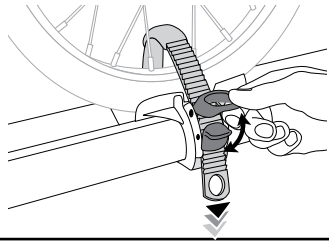

VERIFIQUE QUE LA HORQUILLA ESTÁ ASEGURADA.



VERIFIQUE LA TUERCA HEXAGONAL.

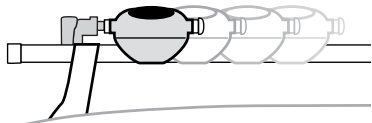
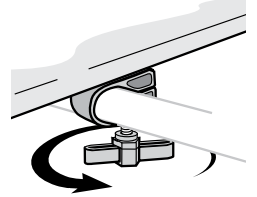

Si ha instalado el portabicicletas entre soportes y quiere reubicarlo en el travesaño:

- ✓ cierre la palanca roja
- ✓ ajuste la tuerca hexagonal

AL VIAJAR

- No transporte bicicletas con asientos para bebés, cestas, guardabarros, cubrebicicletas o motores.
- No lleve bicicletas en tándem o reclindas.
- No se recomienda conducir fuera de la ruta pues podría dañarse el vehículo o la bicicleta.

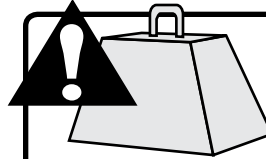

LÍMIT DE CARGA

Separación de 16" (41cm) = 14kg (30 lbs.)/bicicleta

16 kg (35 lbs.)/bicicleta

SI QUITA EL PORTABICICLETAS, SIGA LAS INSTRUCCIONES PARA VOLVER A INSTALARLO.

Haga las verificaciones de seguridad después de cada instalación.

PORTEZUELA TRASERA PROCEDA SIEMPRE CON CAUTELA AL ABRIR LA PORTEZUELA.

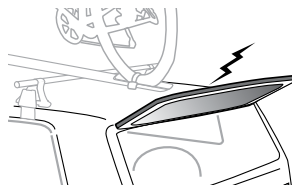

MANTENIMIENTO: Use lubricante no soluble en agua en los tornillos. Use un paño blando con agua y detergente suave para limpiar las partes de plástico.

QUITE EL ACCESORIO ANTES DE ENTRAR EN UN LAVADERO AUTOMÁTICO DE VEHÍCULOS.



ADVERTENCIA: CERCÍOARSE DE QUE TODO EL EQUIPO QUEDÓ ASEGURADO SEGÚN LAS INSTRUCCIONES. LAS UNIONES Y PIEZAS DE MONTAJE PUEDEN AFLOJARSE CON EL TIEMPO. VERIFIQUE ANTES DE CADA USO Y AJUSTE SI ES NECESARIO.

ASISTENCIA TÉCNICA O REPUESTOS

Comuníquese con su distribuidor o llame al (888)925-4621 de lunes a viernes, de 7:00 AM a 5:00 PM hora del Pacífico.



Este producto es cubierto por YAKIMA Garantía limitada a vida "Mientras dure el romance" Para obtener una copia de la garantía limitada, va en línea a www.yakima.com o nos manda correo electrónico en yakwarranty@yakima.com o llamada (888) 925-4621

¡ CONSERVE ESTAS INSTRUCCIONES !