



LockNLoad™ Platform Raised Rail Kit

RAISED RAIL ATTACHMENT SYSTEM FOR LOCKNLOAD PLATFORM

MAXIMUM PRODUCT LOAD RATING: 75 kg 

IMPORTANT:

- **LOAD = WEIGHT OF PLATFORM or BARS + MOUNTING SYSTEM + ACCESSORIES + CARGO**
- **PLEASE REFER TO VEHICLE MANUFACTURER SPECIFICATIONS FOR MAX ROOF LOAD CAPACITY OF VEHICLE. THE LOWEST LOAD RATING APPLIES.**
- **OFFROAD RATING: SCAN QR CODE FOR LOCKNLOAD LOAD RATING GUIDE. REDUCTIONS MAY APPLY.**



FIRST TIME INSTALLATION

- Please read instructions carefully before installation.
- Check the contents of kit. Contact your YAKIMA dealer if any parts appear missing or damaged.
- Clean your roof thoroughly prior to fitting the LockNLoad Platform Raised Rail Kit.
- Place these instructions in the vehicle's glove box after installation is complete.

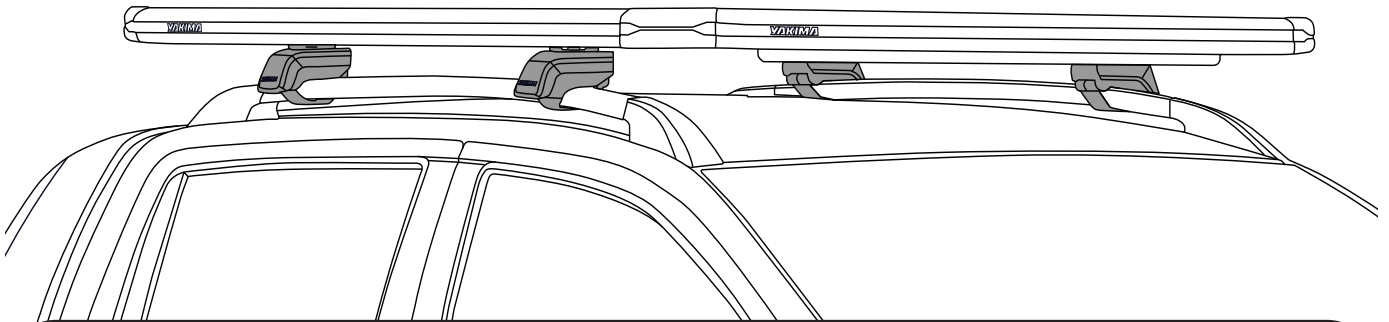

KIT CONTENTS

ITEM	COMPONENT	QTY
1.	Raised Rail Leg Assembly	x4
2.	Yakima Key Set	x1
3.	4 mm Ball End Allen Key	x1



TOOLS REQUIRED:

- 4 mm Ball End Allen Key or Torque Wrench
- 10 mm Socket Wrench or Spanner



PLATFORM SOLD SEPARATELY

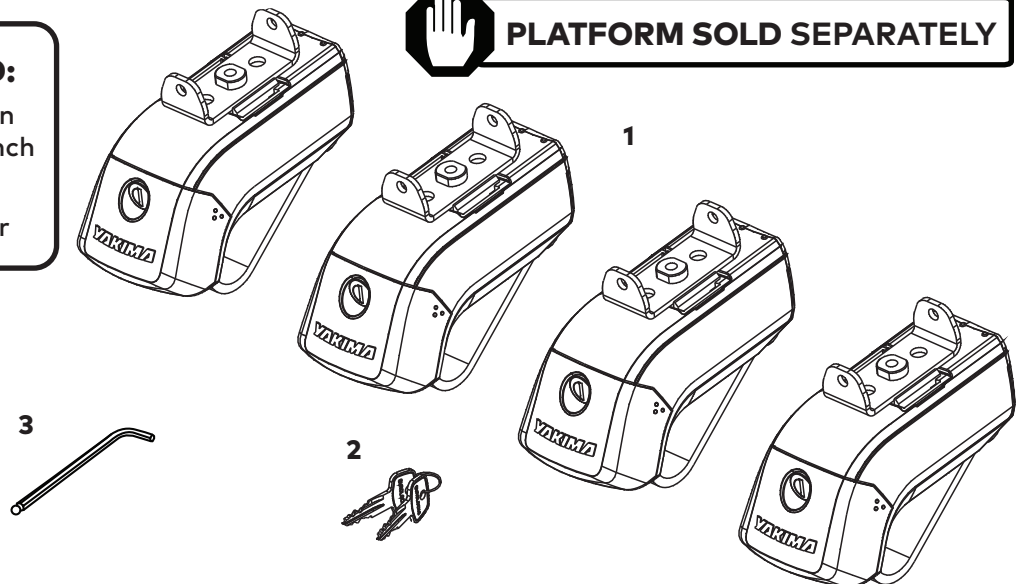

8000389

INSTALLATION

1 REMOVE LEG COVERS.

Using the keys remove all leg covers.

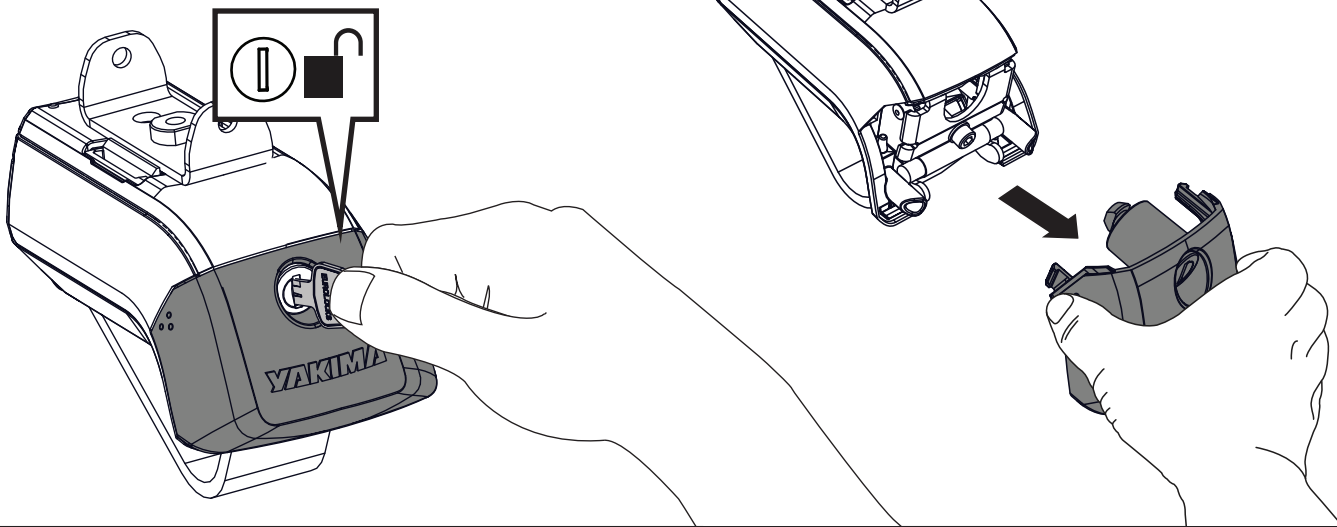

2 BACK OUT BOLTS AND RELEASE STRAPS.

Using the supplied allen key or a cordless drill, loosen the pictured bolt on all legs until the straps can be lifted out of the cradle.

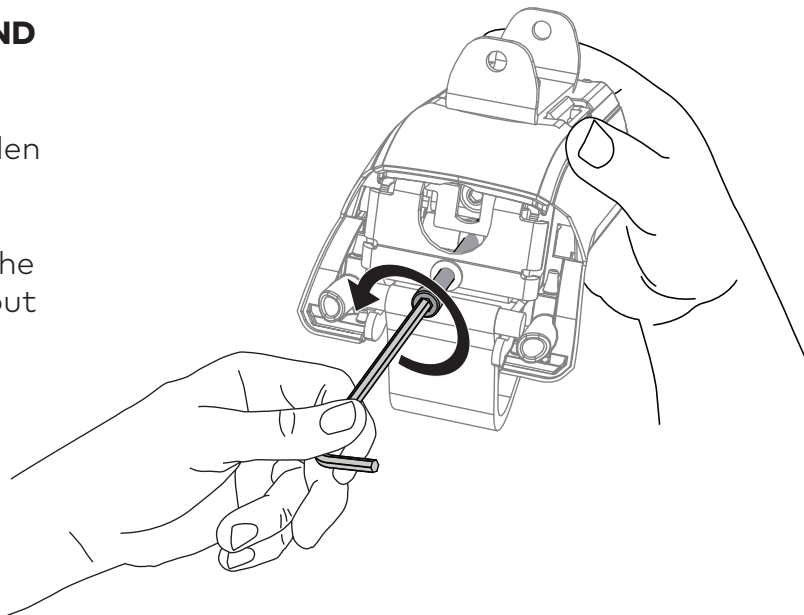

Unhook straps by lifting out of cradle and pulling downwards.

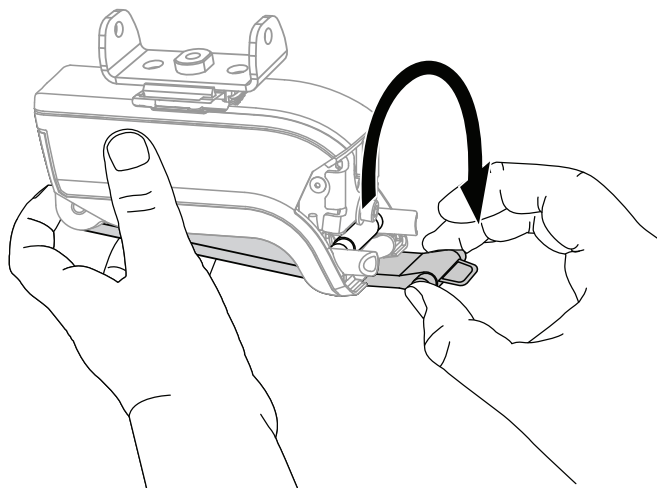

3

PIVOT MOUNT INSTALL.

From the platform kit (sold separately) insert bushes in the desired location on either side of the pivot mount.

Place a pivot mount on top of each leg assembly, lining up the bushes on pivot mount with the holes on pivot bracket.

Secure with the M6 socket head cap screw and M6 washer (outboard of vehicle) and M6 spacer and M6 nyloc nut (inboard of vehicle) from this kit **in the order as shown.**

Tighten all M6 socket head cap screws to 4 Nm with included 5 mm allen key and nuts with a 10 mm spanner or suitable torque wrench.

NOTE - The pivot mount assembly will still have movement after securing which is intended.

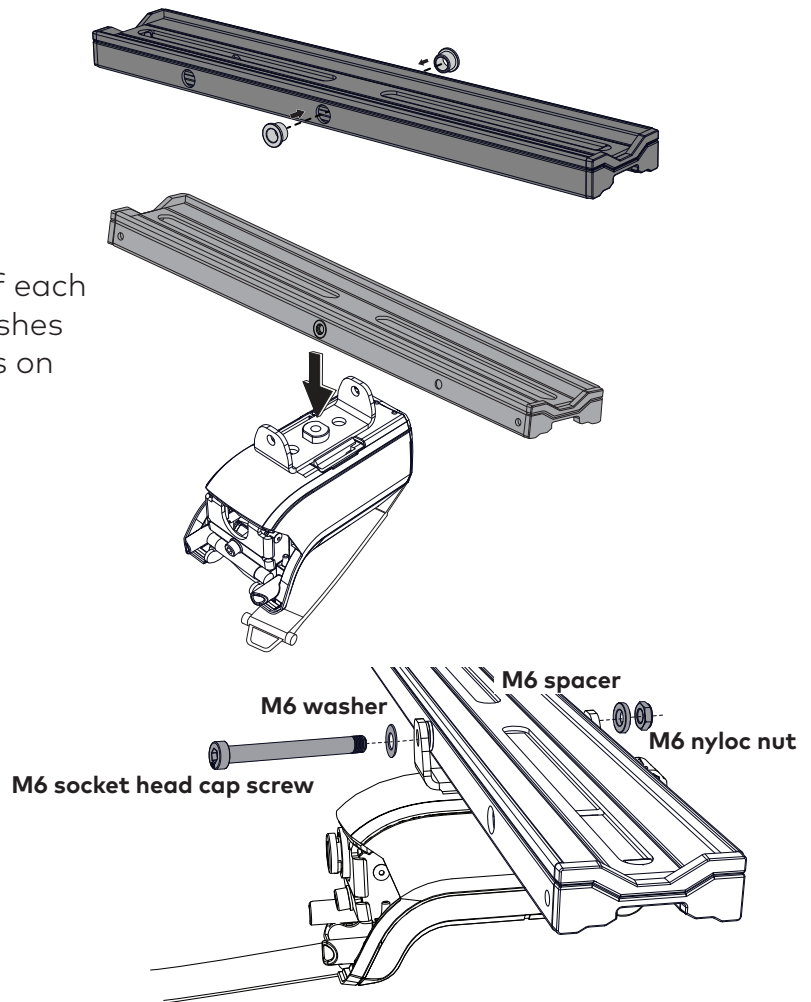

4

ATTACH LEG AND PIVOT MOUNT ASSEMBLIES TO RAIL.

Place leg and pivot mount assemblies on top of rail, ensuring that the hole on the underside of the assembly is positioned directly on top of the rail.

Check that strap can pass underneath the rail and re-engage with the cradle. If not, back off bolt shown in step 2 further.

Re-engage straps and tighten bolts until the assemblies are stable on the rail. Do not tighten completely.

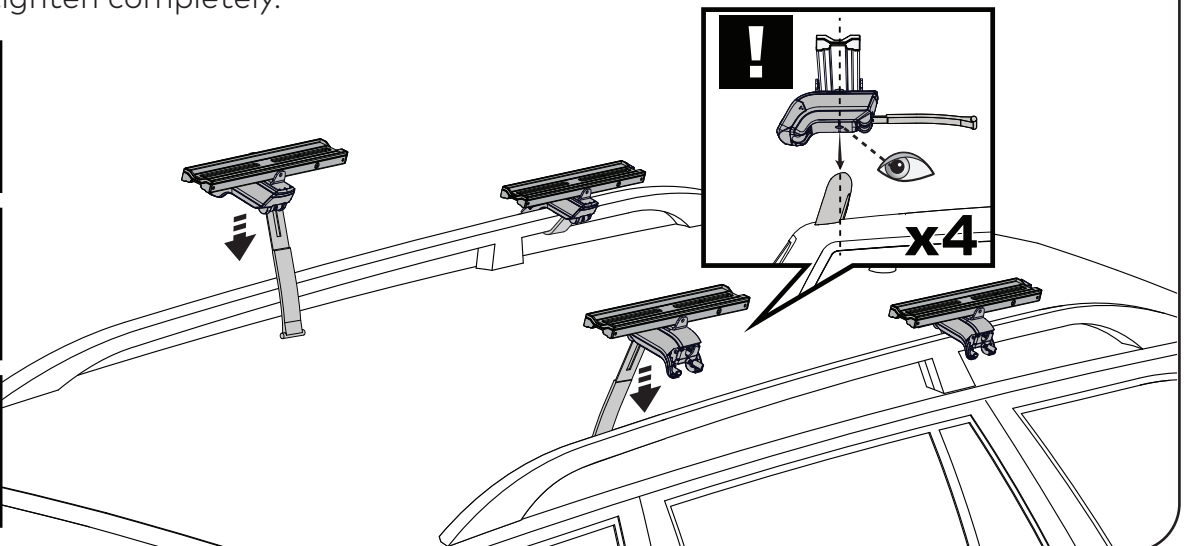
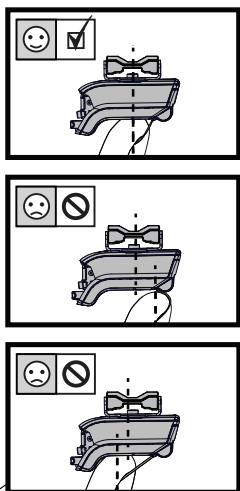

5**POSITION LEG AND PIVOT MOUNT ASSEMBLIES ALONG RAIL.**

The minimum recommended distance between leg and pivot mount assemblies along the rail is 700 mm.

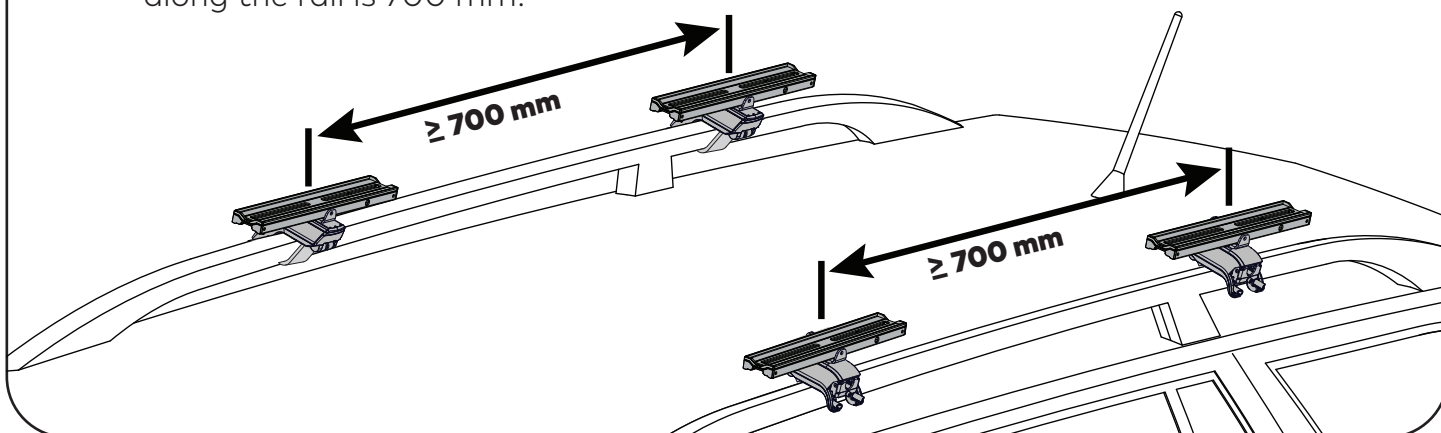
**6****PLATFORM MOUNTING INSTRUCTIONS.**

If platform was purchased unassembled, follow the LockNLoad platform assembly instructions (footer number 28-13-337) to piece platform together.

If platform was purchased pre-assembled, follow the LockNLoad pre-assembled platform assembly instructions (footer number 6100005105) from the 'Platform Mounting Instructions' page.

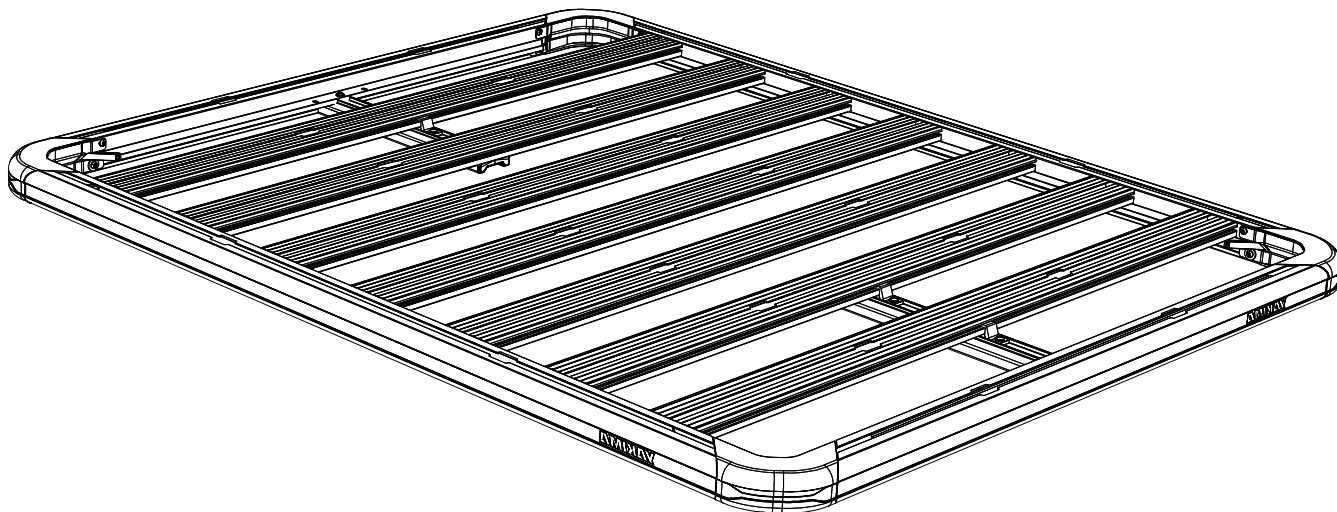

7**TIGHTEN STRAPS.**

Using the supplied allen key, tighten bolts on all legs to 6 Nm

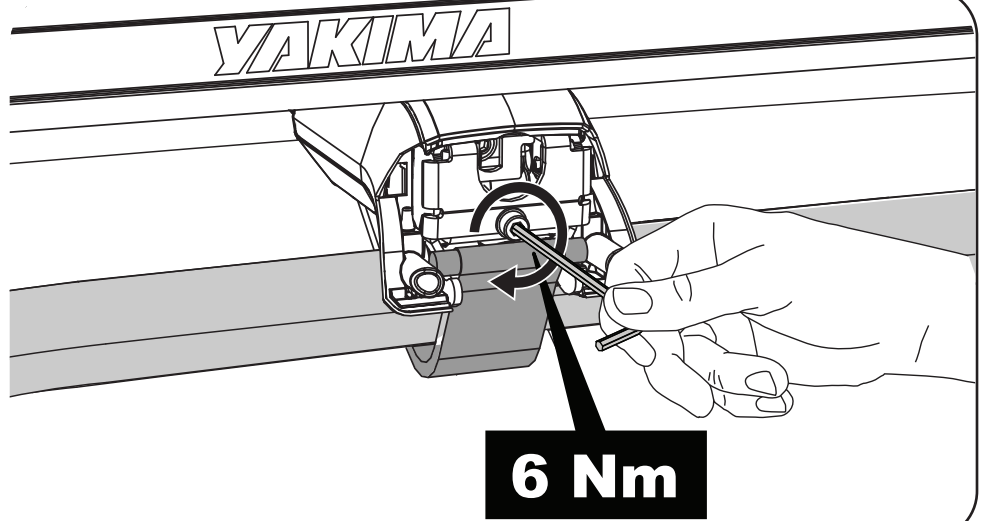
**8****FIT LEG COVERS.**

Using the keys and covers, fit and lock all leg covers.

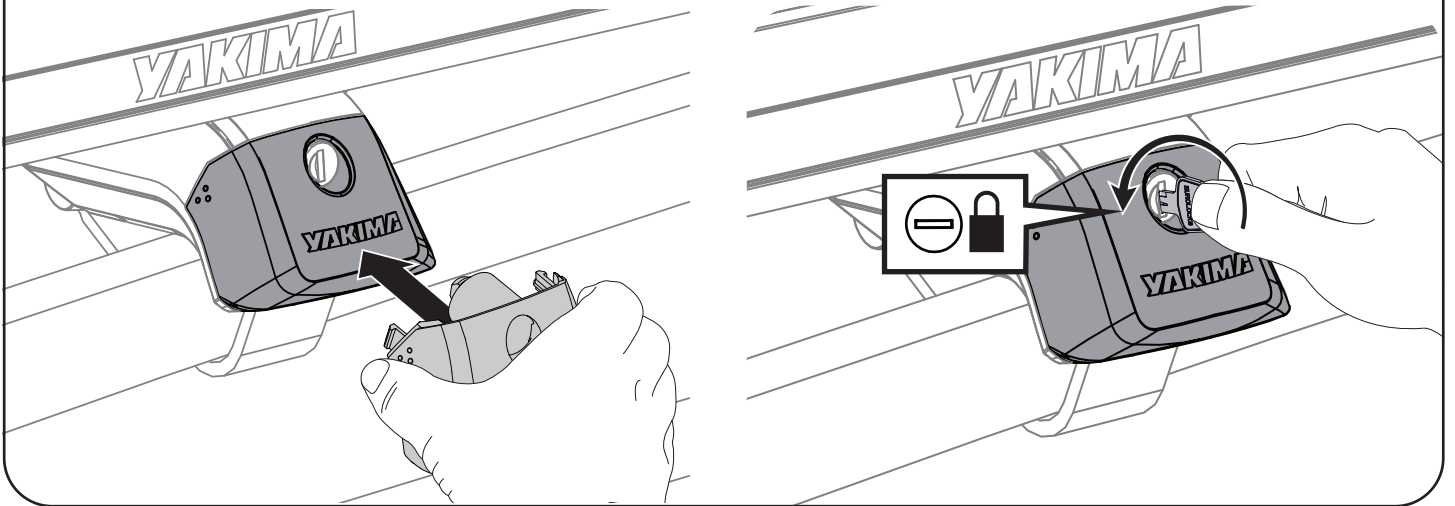
**9****PLATFORM MOUNTING COMPLETE.**

Check that platform has been secured correctly as per the mounting instructions.

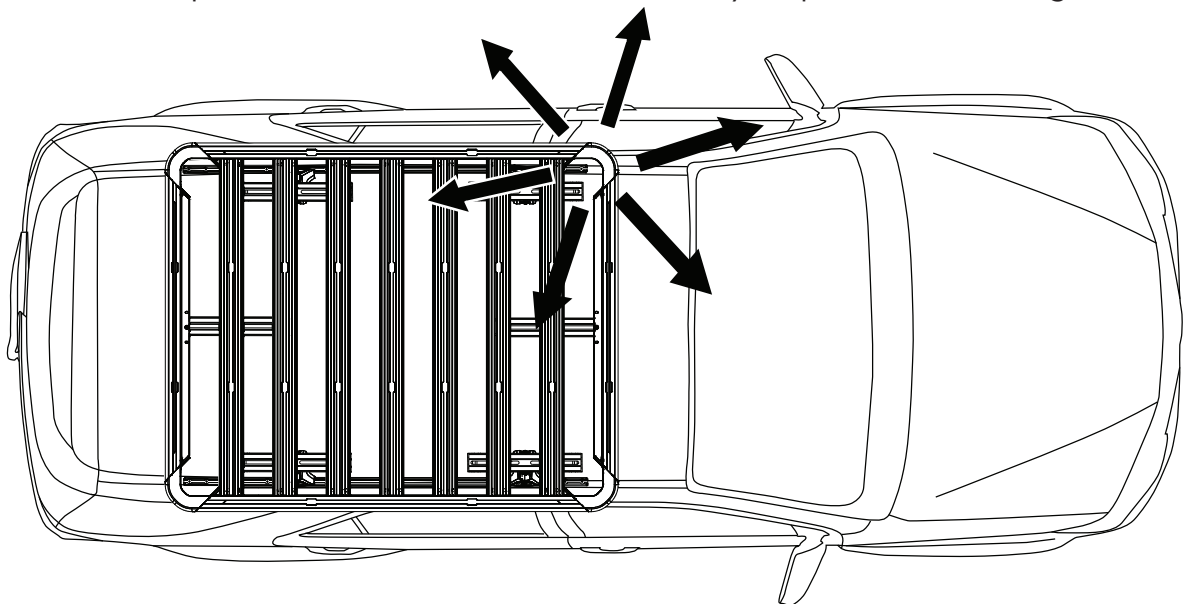

NOTE - 7 slat platform shown - indicative sizes A and B.



www.yakima.com.au
www.yakima.co.nz
www.yakima.com
www.yakima.eu

YAKIMA AUSTRALIA PTY LTD

17 Hinkler Court
Brendale, QLD 4500
Australia
1800 143 548
yakima.com.au/contact-us

YAKIMA PRODUCTS, INC.

4101 Kruse Way
Lake Oswego, OR
97035-2541
USA
888 925 4621
yakima.com/support