

MAXIMUM PRODUCT LOAD RATING: 150 kg



IMPORTANT:

- **LOAD = WEIGHT OF PLATFORM or BARS + MOUNTING SYSTEM + ACCESSORIES + CARGO**
- **PLEASE REFER TO VEHICLE MANUFACTURER SPECIFICATIONS FOR MAX ROOF LOAD CAPACITY OF VEHICLE. THE LOWEST LOAD RATING APPLIES.**
- **OFFROAD RATING: SCAN QR CODE FOR LOCKNLOAD LOAD RATING GUIDE. REDUCTIONS MAY APPLY.**



FIRST TIME INSTALLATION

- Please read instructions carefully before installation.
- Check the contents of kit. Contact your YAKIMA dealer if any parts appear missing or damaged.
- Clean your roof thoroughly prior to fitting the LockNLoad Heavy Duty Roof Rack System.
- Place these instructions in the vehicle's glove box after installation is complete.



TOOLS REQUIRED:

- 13 mm Socket Wrench
- 13 mm Spanner
- 10 mm Open Ended Spanner
- #2 Phillips Head Screwdriver
- Torque Wrench (Optional)
- Rubber Mallet (Optional)
- Tape Measure
- Scissors
- Spirit Level

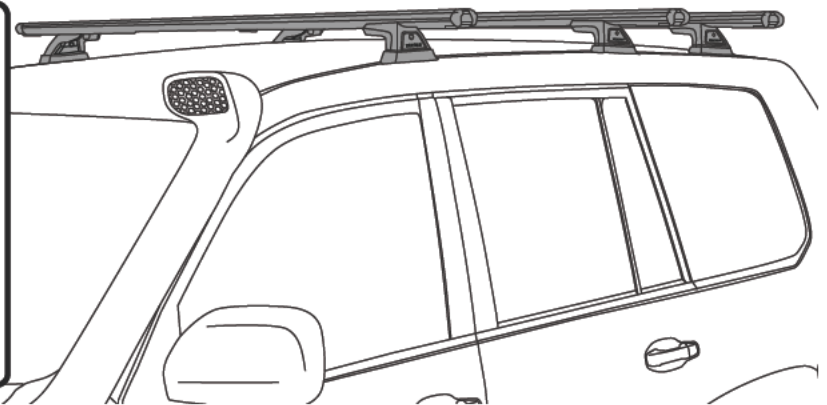

KIT CONTENTS

ITEM	COMPONENT	QTY	ITEM	COMPONENT	QTY
1.	M6 Washer	x6	6.	Front Left Pad (2804021)	x1
2.	M6 Set Screw 30 mm	x6	7.	Middle Left Pad (2804022)	x1
3.	M8 Washer	x12	8.	Rear Left Pad (2804023)	x1
4.	M8 Hex Bolt 40 mm	x12	9.	Front Right Pad (2804024)	x1
5.	Foam Adhesive	x12	10.	Middle Right Pad (2804025)	x1
			11.	Rear Right Pad (2804026)	x1



LEG AND BAR COMPONENTS SOLD SEPARATELY

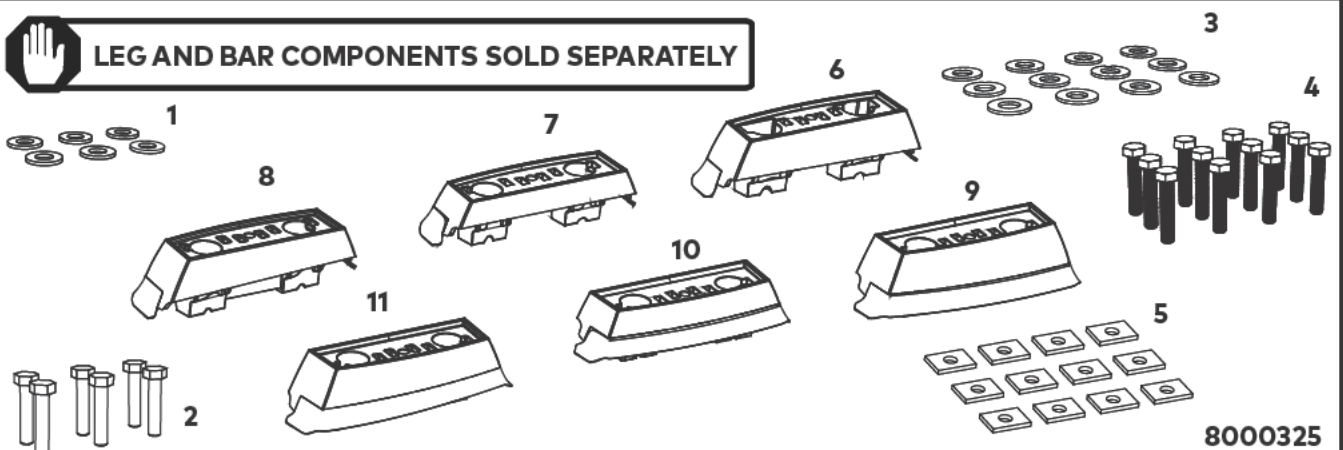

8000325

INSTALLATION

1 REMOVE FIXED POINT HARDWARE

Remove fixed-point covers.

Remove bolts, washers and brackets from the vehicle's fixed points.

Store items away in a safe place.

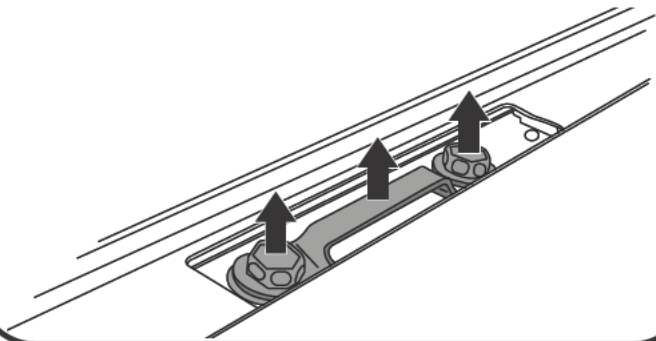

2 AFFIX FOAM ADHESIVE

Apply Foam Adhesive over holes on underside of Pads.

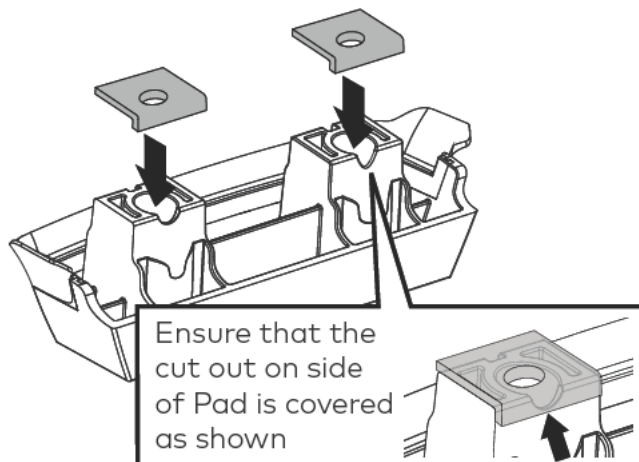

3 PAD POSITIONING

Place Pads over vehicle's fixed points as shown.

It is important to put the Pads in the correct position on the vehicle.

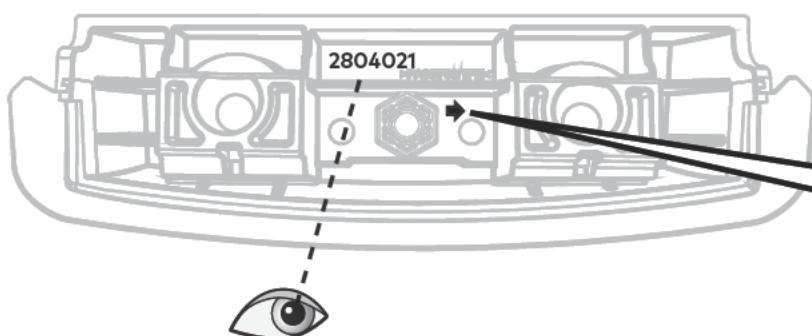

Ensure that the arrows on underside of Pads are facing the front of vehicle



- | | | |
|--------------------|--------------------|--------------------|
| 1 = 2804021 | 2 = 2804022 | 3 = 2804023 |
| 4 = 2804024 | 5 = 2804025 | 6 = 2804026 |

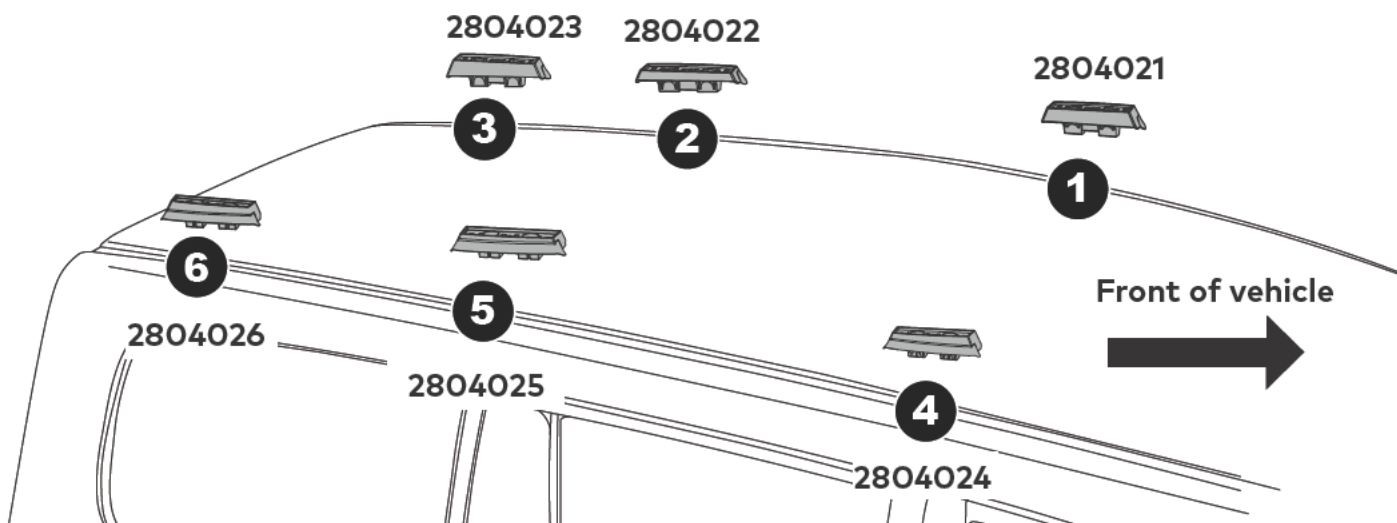

4 SECURE PADS TO FIXED POINTS

Assemble 1 x M8 Washer onto each M8 Hex Bolt 40 mm as shown. Insert into Pads.

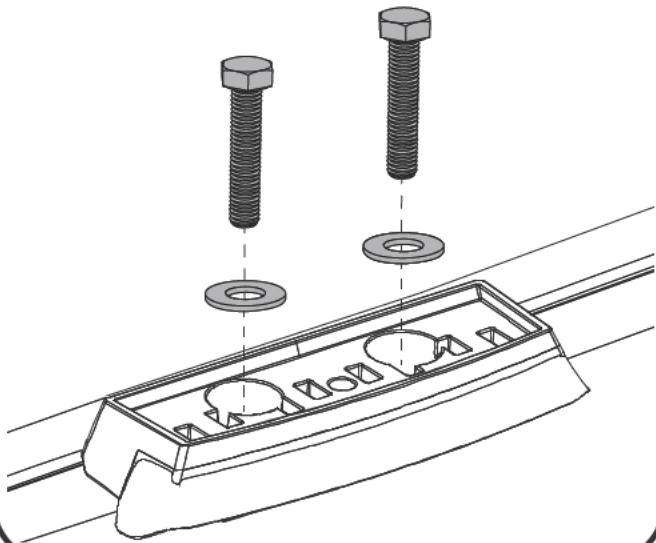

5

Tighten all M8 Hex Bolts to 7 Nm using 13 mm Socket Wrench. Check all Bolts are completely tightened down and secure as required.

Do not over tighten.

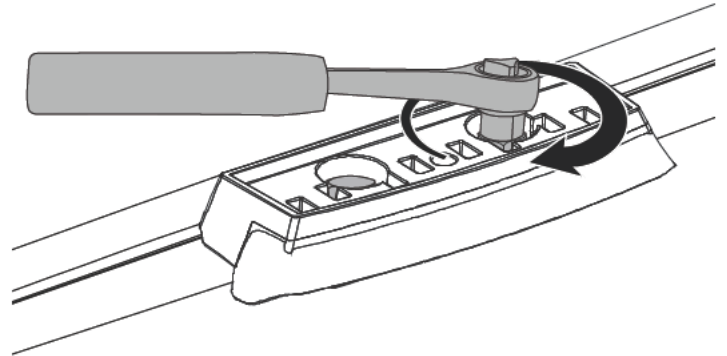

IF INSTALLING LOCKNLOAD ROOF RACKS, CONTINUE ON TO STEP 6

IF INSTALLING A LOCKNLOAD PLATFORM, SWITCH TO YOUR PLATFORM INSTRUCTIONS

6 REMOVE END CAPS FROM BARS

From the LockNLoad Bar Kit (sold separately), remove Plastite Screw from each Bar end using a #2 Phillips Head Screwdriver and pull out End Caps from Bars.

Keep all parts aside for later installation.

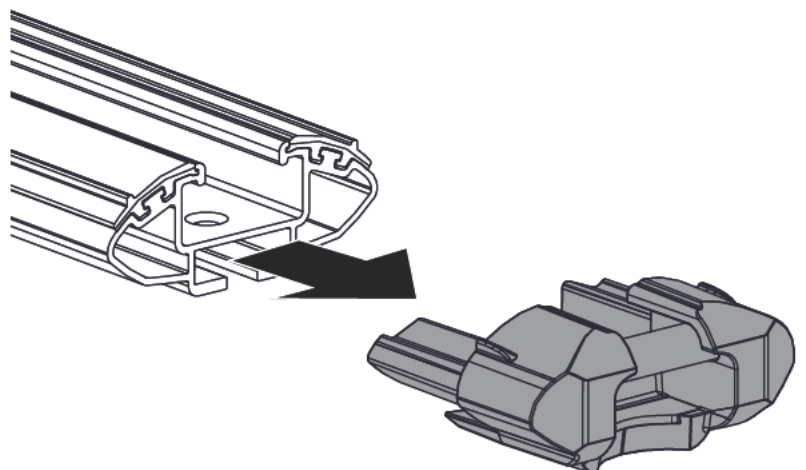
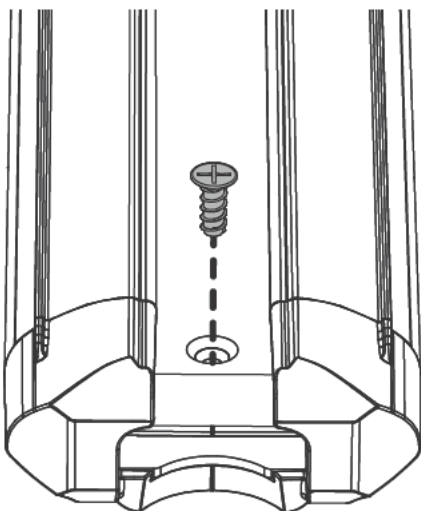

7 REMOVE LEG COVERS

Using the keys supplied in the LockNLoad Leg Kit (sold separately), remove all Leg Covers.

8 INSERT LEGS

Slide the pre-assembled Leg assemblies into the underside channel of LockNLoad Bars.

If Leg assemblies will not slide in, loosen Screws to increase gap.

9 BAR SLOT COVERS

From the LockNLoad Bar Kit, cut Bar Slot Covers as per the table and press into underside channel of each Bar end as shown.

BAR SLOT COVER CUT MEASUREMENTS		
Front Bar	Middle Bar	Rear Bar
240 mm x2	229 mm x2	214 mm x2

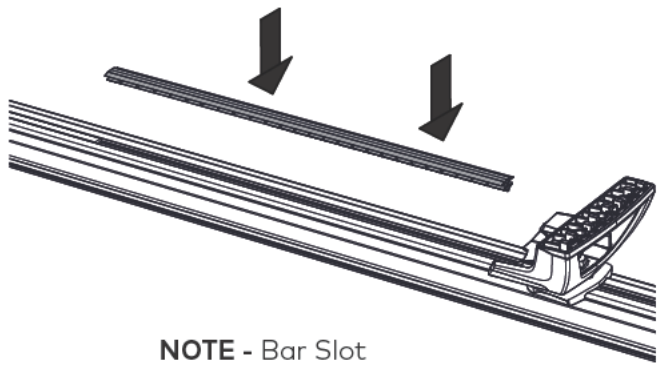

NOTE - Bar Slot Covers to be inserted with flat side visible

10 CHECK LEG TO LEG MEASUREMENTS

With a Tape measure check leg to leg measurements are correct as per the table. Ensure measurements are taken from the centre of the Legs as shown.

LEG TO LEG MEASUREMENTS		
Front Bar	Middle Bar	Rear Bar
1058 mm	1033 mm	1007 mm

11**BAR SLOT COVERS (OUTSIDE LEG)**

Measure the Bar channel outside of the Legs and subtract 20 mm from this measurement. Using the remaining pieces of Slot Cover from Step 9, cut to this length and insert into the underside channel of each Bar end as shown.

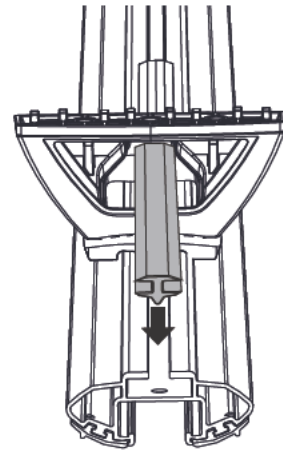
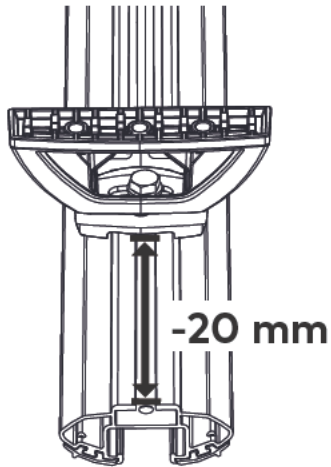
**12****SECURE END CAPS TO BARS**

Insert the End Caps as shown. A Rubber Mallet can be used to assist installation.

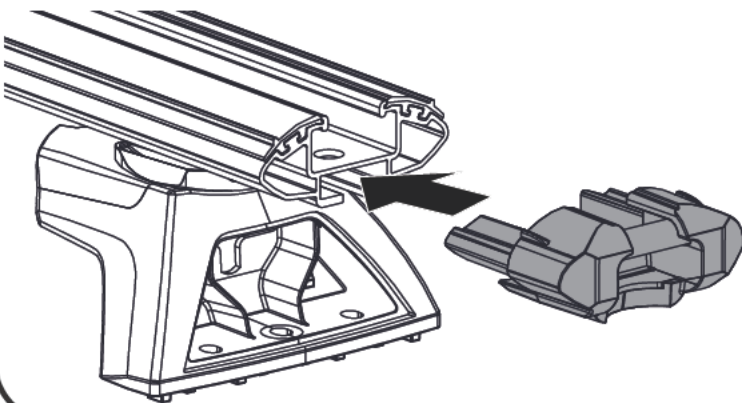
**13**

Secure using Plastite Screw (from LockNLoad Bar kit). Tighten using a #2 Phillips Head Screwdriver.

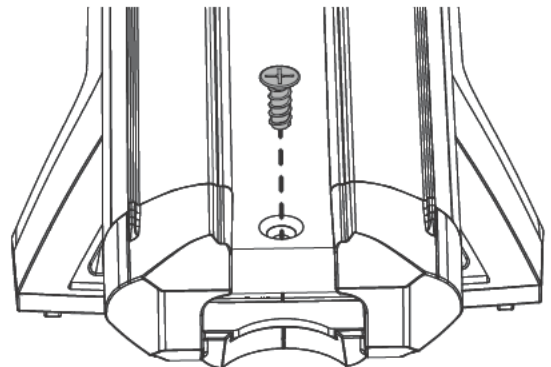
**14****BAR FITMENT**

Carefully place Bar assembly over Pads.

Take care not to damage vehicle.

Once positioned, locate the raised notches on base of Legs into the recesses on Pads. Repeat for all Bars.

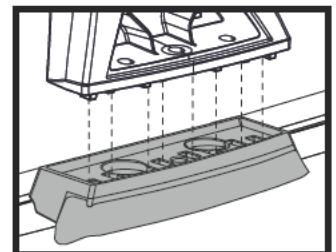
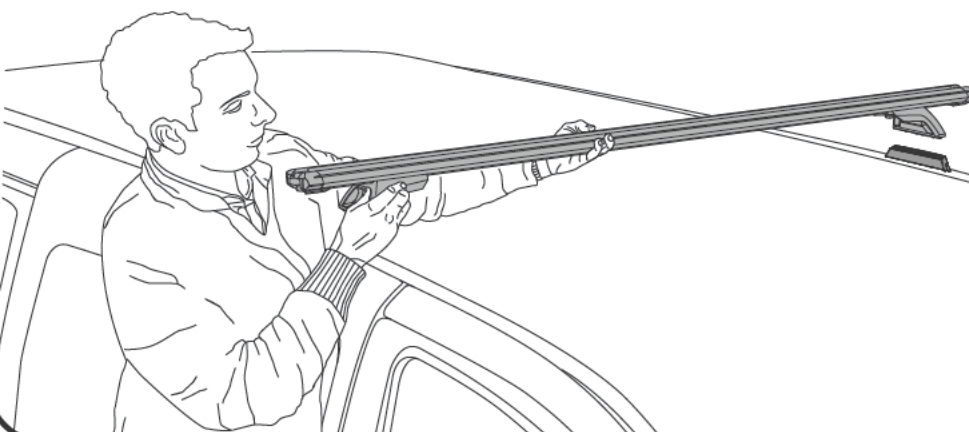

15**SECURE BARS TO PADS**

From the LockNLoad Mounting kit, assemble 1 x M6 Washer onto each M6 set screw 30 mm as shown. Insert through the centre hole on Leg into Pad.

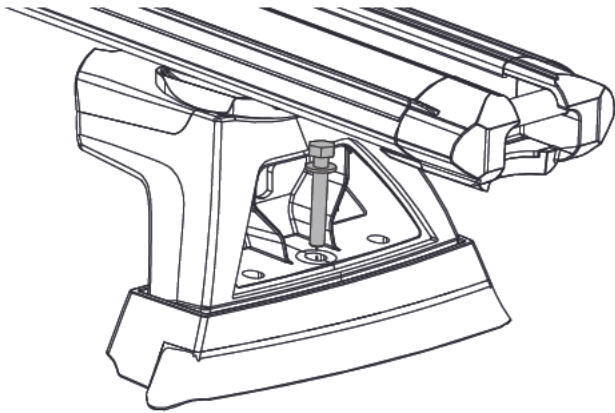
**16**

Tighten all M6 set screws to 7 Nm using 10 mm Open Ended Spanner.

Do not over tighten.

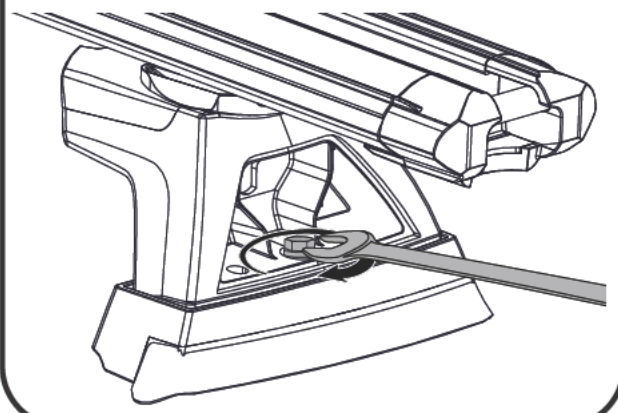
**17****LEVEL BARS**

With vehicle on a level surface, adjust all Bar angles to be level using a Spirit Level.

The Bar angle can be adjusted to reduce any wind noise. In most cases this is achieved by getting the Bar in-line with air flow parallel to the ground.

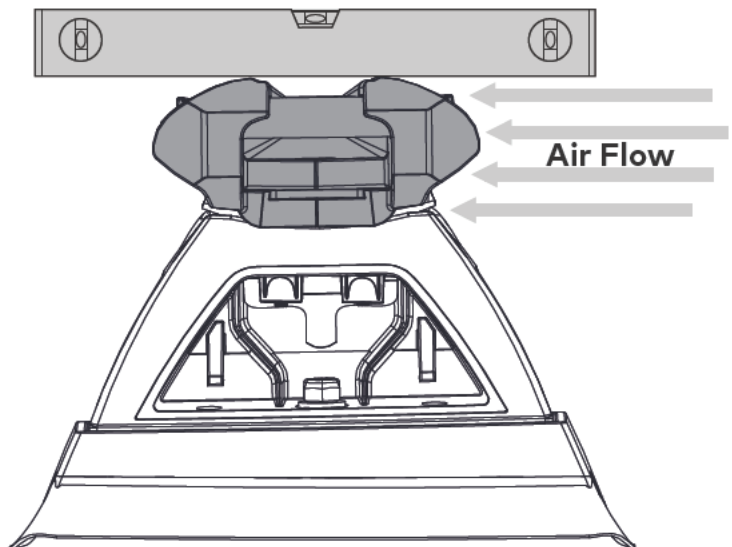
**18****SECURE LEGS TO BARS**

Tighten all M8 Set Screws to 9 Nm using a 13 mm Spanner.

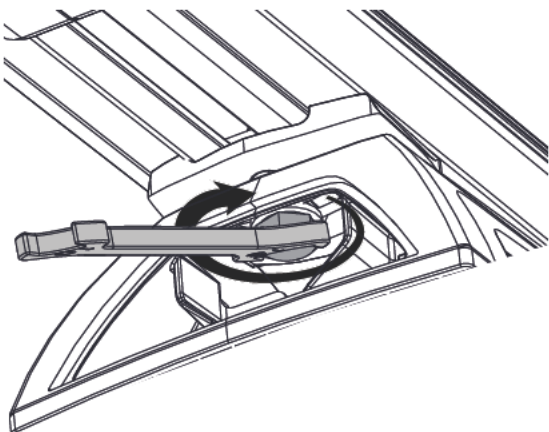
**19****CHECK BAR LEGS ARE SECURE**

Check all Bar Legs are secure.

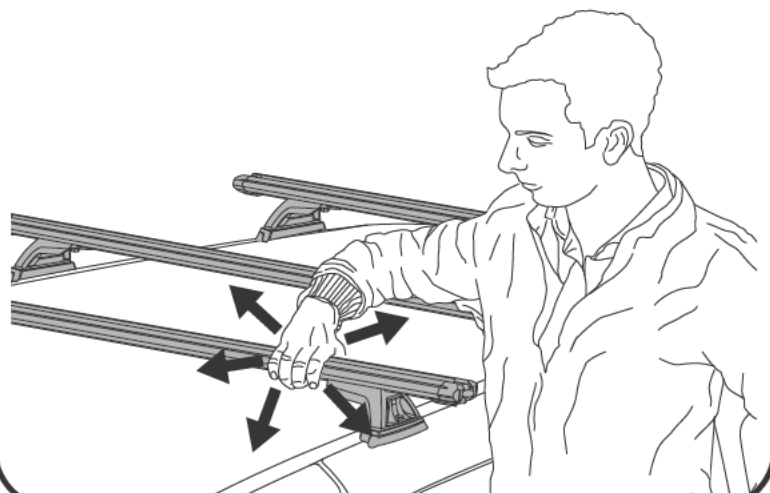

20**FIT LEG COVERS**

Using the keys and Covers supplied in the LockNLoad Leg Kit, fit and lock all Leg Covers.

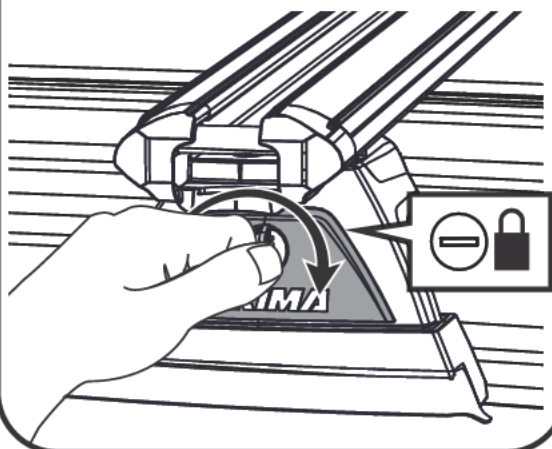
**21****BAR KEYS**

Place one key on the vehicle key ring and put the other away safely, or store with the spare vehicle key.

Write the key number (which is stamped on the key) in the box provided. Replacement keys are available from Yakima stockists, visit www.yakima.com.au or www.yakima.co.nz to find your nearest store or contact us directly on 1800 143 548 (AU) or 0800 4776 722 (NZ).

Key Number:

[Dashed box for writing the key number]

YAKIMA

www.yakima.com.au

www.yakima.co.nz

www.yakima.com

www.yakima.eu

YAKIMA AUSTRALIA PTY LTD

17 Hinkler Court
Brendale, QLD 4500
Australia
1800 143 548

YAKIMA PRODUCTS, INC.

4101 Kruse Way
Lake Oswego, OR
97035-2541
USA
888 925 4621

ALL CONTENT SUBJECT TO YAKIMA AUSTRALIA PTY LTD COPYRIGHT © 2015