

MAXIMUM PRODUCT LOAD RATING: 150 kg



IMPORTANT:

- **LOAD = WEIGHT OF PLATFORM or BARS + MOUNTING SYSTEM + ACCESSORIES + CARGO**
- **PLEASE REFER TO VEHICLE MANUFACTURER SPECIFICATIONS FOR MAX ROOF LOAD CAPACITY OF VEHICLE. THE LOWEST LOAD RATING APPLIES.**
- **OFFROAD RATING: SCAN QR CODE FOR LOCKNLOAD LOAD RATING GUIDE. REDUCTIONS MAY APPLY.**



FIRST TIME INSTALLATION

- Please read instructions carefully before installation.
- Check the contents of kit. Contact your YAKIMA dealer if any parts appear missing or damaged.
- Clean your roof thoroughly prior to fitting the LockNLoad Heavy Duty Roof Rack System.
- Place these instructions in the vehicle's glove box after installation is complete.



TOOLS REQUIRED:

- 13 mm Socket Wrench
- 13 mm Spanner
- 10 mm Open Ended Spanner
- #2 Phillips Head Screwdriver
- Torque Wrench (Optional)
- Rubber Mallet (Optional)
- Tape Measure
- Scissors
- Spirit Level

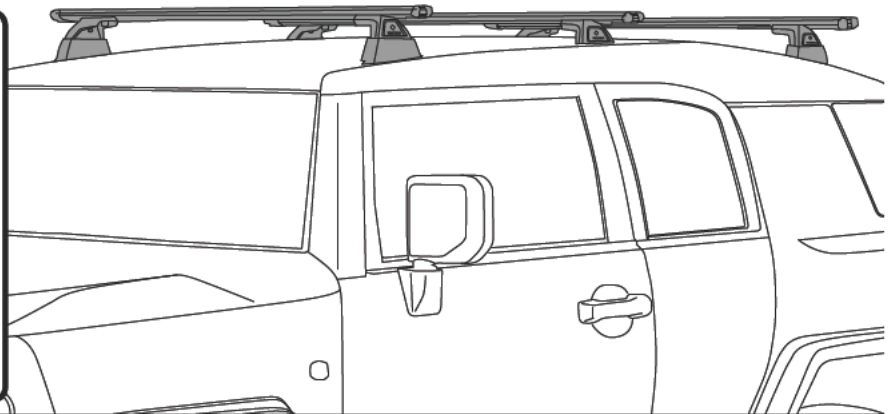

KIT CONTENTS

ITEM	COMPONENT	QTY	ITEM	COMPONENT	QTY
1.	M6 Set Screw 30 mm	x4	8.	Front Left Pad (2804031)	x1
2.	M6 Washer	x6	9.	Middle Left Pad (2803081)	x1
3.	M8 Hex Bolt 25 mm	x4	10.	Rear Left Pad (2804035)	x1
4.	M8 Hex Bolt 40 mm	x8	11.	Front Right Pad (2804032)	x1
5.	M8 Washer	x12	12.	Middle Right Pad (2803082)	x1
6.	Foam Adhesive	x12	13.	Rear Right Pad (2804036)	x1
7.	M6 Set Screw 20 mm	x2			



LEG AND BAR COMPONENTS SOLD SEPARATELY

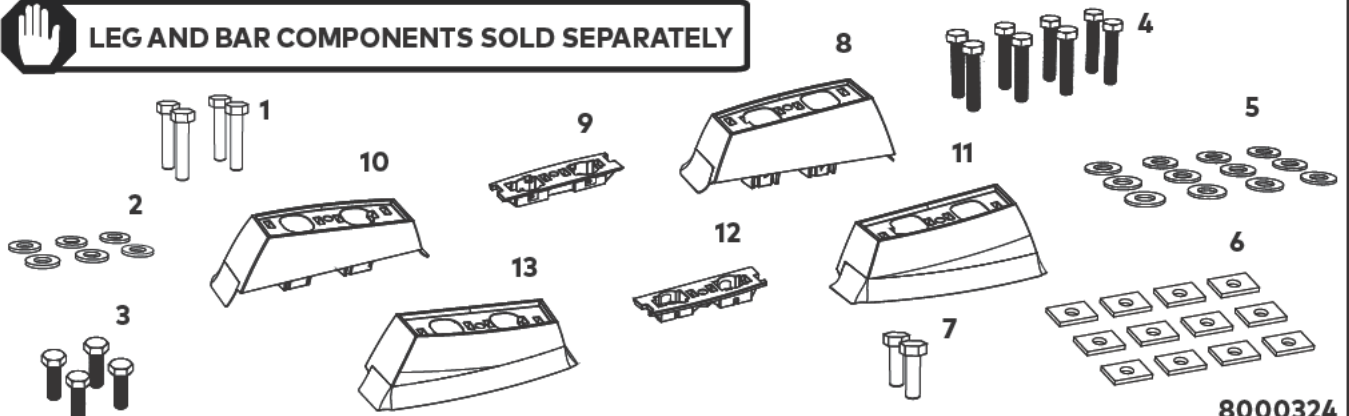

8000324

INSTALLATION

1 REMOVE FIXED POINT HARDWARE

Remove fixed-point covers.

Remove bolts, washers and brackets from the vehicle's fixed points.

Store items away in a safe place.



2 AFFIX FOAM ADHESIVE

Apply Foam Adhesive over plastic tubes in the vehicle's mounting holes, with adhesive side to vehicle.

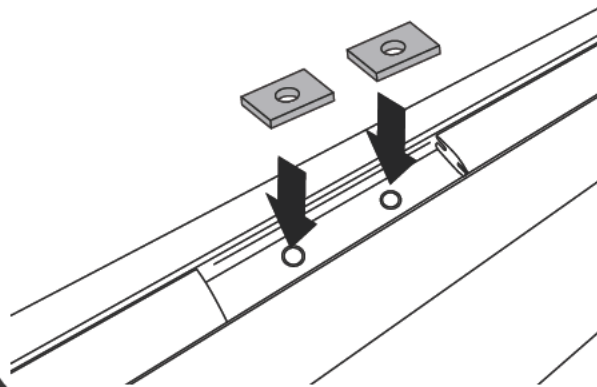

3 PAD POSITIONING

Place Pads over vehicle's fixed points as shown. It is important to put the Pads in the correct position on the vehicle.

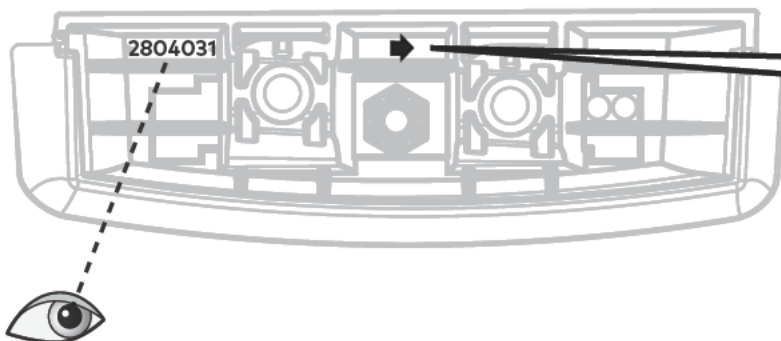

Ensure that the arrows on underside of Pads are facing the front of vehicle



- | | | |
|-------------|-------------|-------------|
| 1 = 2804031 | 2 = 2803081 | 3 = 2804035 |
| 4 = 2804032 | 5 = 2803082 | 6 = 2804036 |

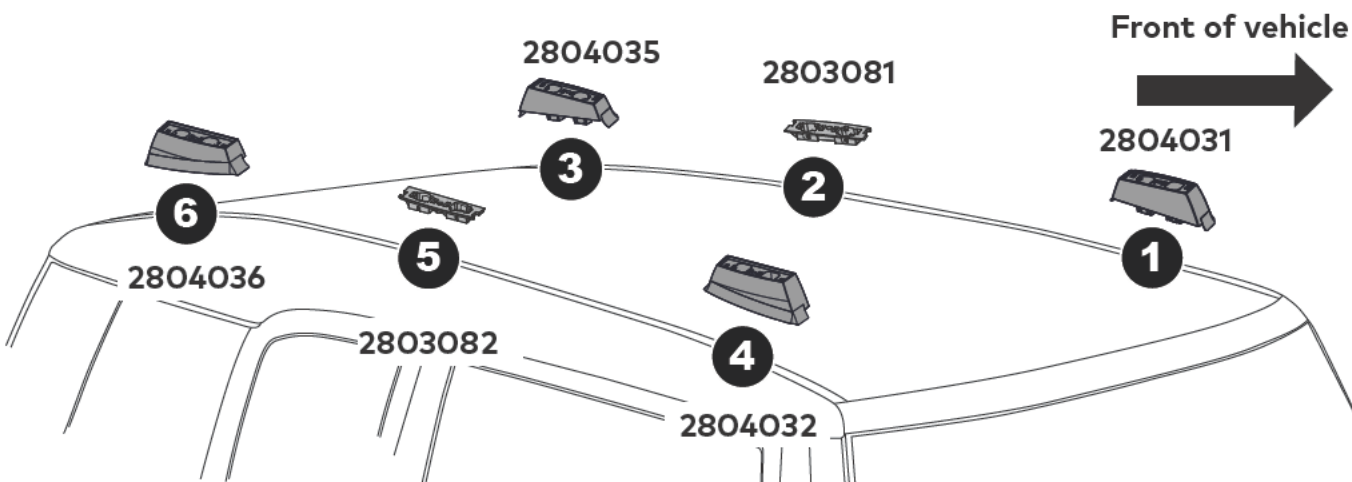

4 SECURE PADS TO FIXED POINTS

Assemble 1 x M8 Washer onto each M8 Hex Bolt (40 mm and 25 mm).

Insert into Pads as per the table.

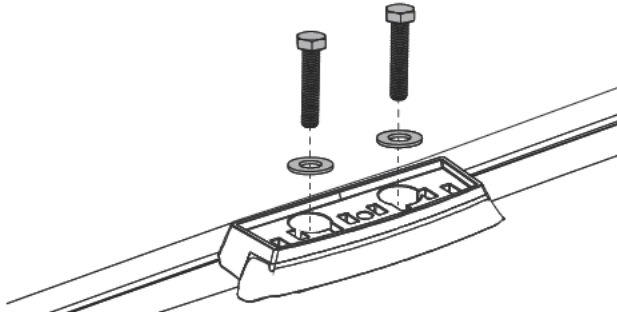

Front and Rear Pads	M8 Hex Bolt 40 mm
Middle Pads	M8 Hex Bolt 25 mm

5 Tighten all M8 Hex Bolts to 7 Nm using 13 mm Socket Wrench.

Check all Bolts are completely tightened down and secure as required.

Do not over tighten.

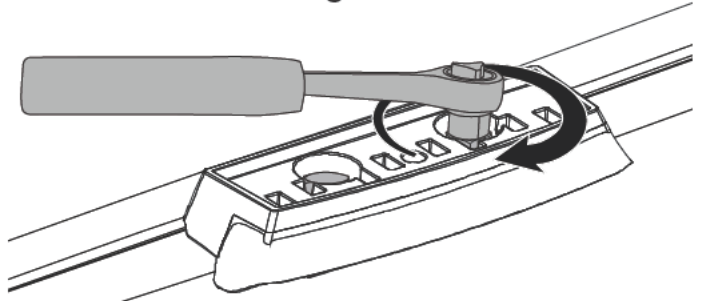

IF INSTALLING LOCKLOAD ROOF RACKS, GO TO STEP 6 ON NEXT PAGE

IF INSTALLING LOCKLOAD PLATFORM, FOLLOW SPECIAL NOTE BELOW BEFORE SWITCHING TO YOUR PLATFORM INSTRUCTIONS



SPECIAL NOTE FOR LOCKLOAD PLATFORM INSTALLS ONLY

Switch to your Platform instructions for the remaining steps. The only point of difference, specific to the FJ Cruiser, is in relation to how the mount blocks attach as detailed here:

Use the offset mount points on both the front and rear pivot mounts to ensure mount blocks are positioned correctly in relation to the Platform as per images below.

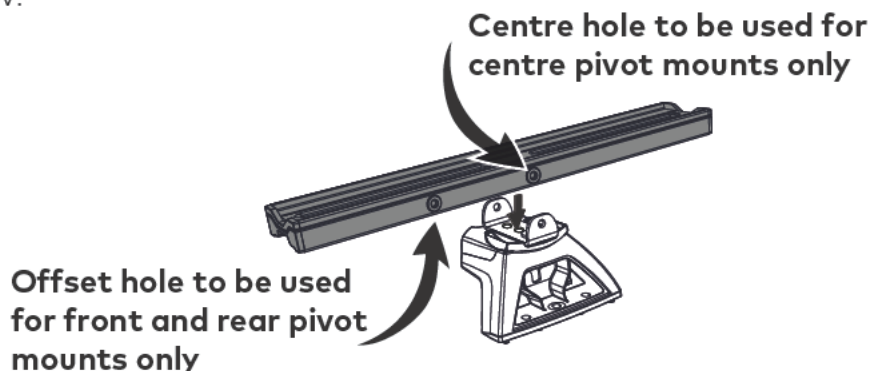

If installed properly, the mounts should look like this - with the longer sections of the front and rear mounts both pointing towards the leg in the centre.

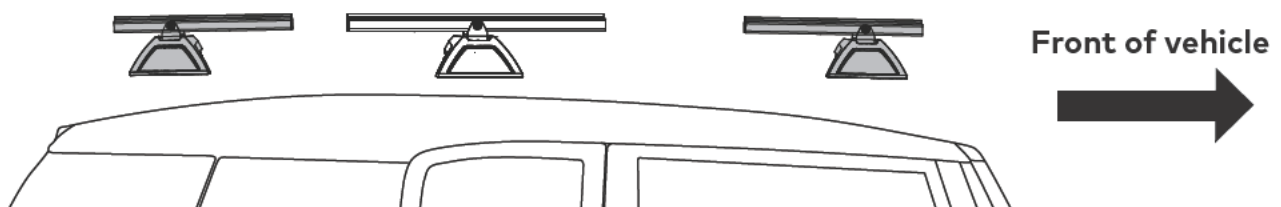

6

REMOVE END CAPS FROM BARS

From the LockNLoad Bar Kit (sold separately), remove Plastite Screw from each Bar end using a #2 Phillips Head Screwdriver and pull out End Caps from Bars.

Keep all parts aside for later installation.

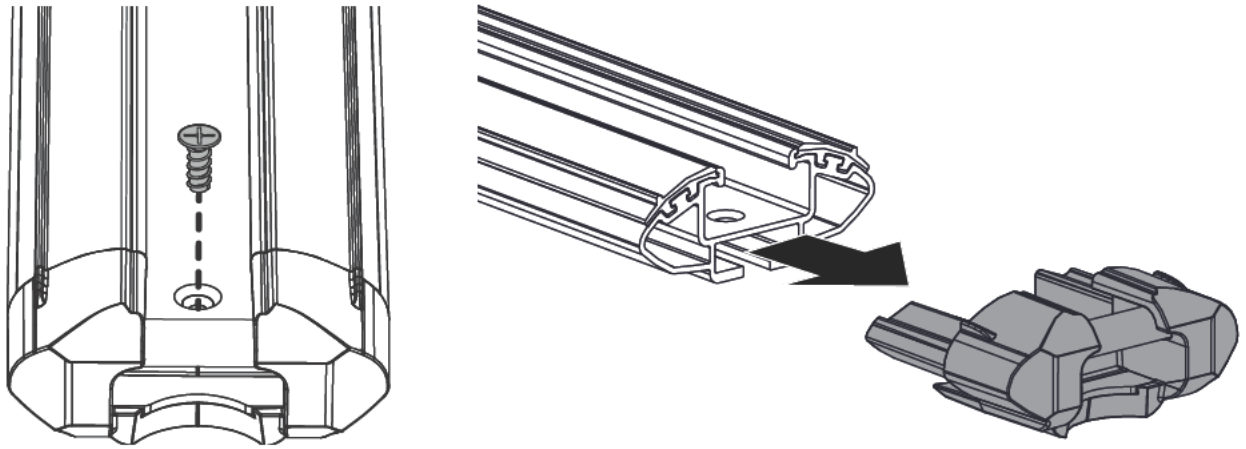

7

REMOVE LEG COVERS

Using the keys supplied in the LockNLoad Leg Kit (sold separately), remove all Leg Covers.

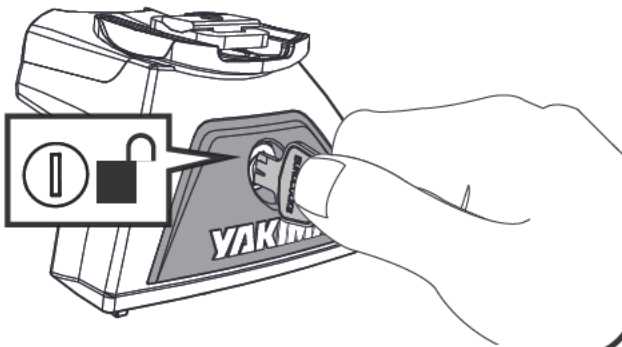

8

INSERT LEGS

Slide the pre-assembled Leg assemblies into the underside channel of LockNLoad Bars.

If Leg assemblies will not slide in, loosen Screws to increase gap.

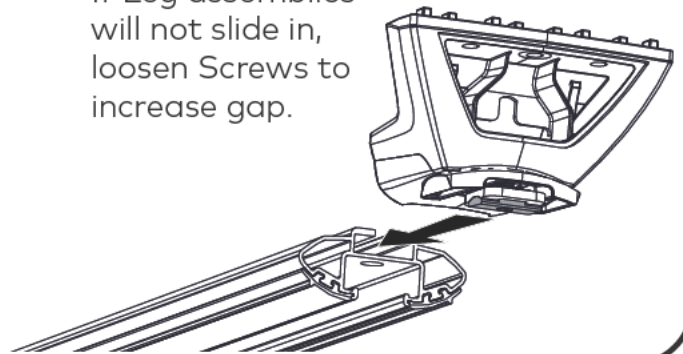

9

BAR SLOT COVERS

From the LockNLoad Bar Kit, cut Bar Slot Covers as per the table and press into underside channel of each Bar end as shown.

BAR SLOT COVER CUT MEASUREMENTS		
Front Bar	Middle Bar	Rear Bar
232 mm x2	200 mm x2	180 mm x2

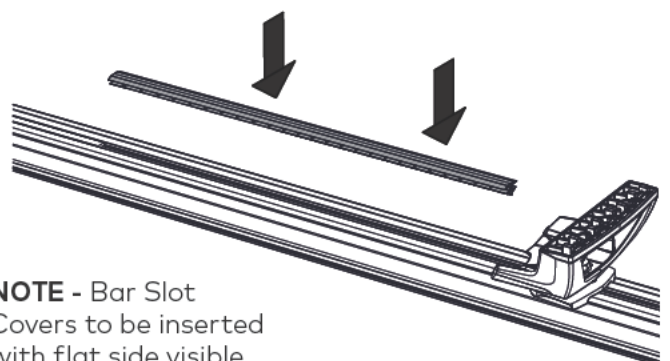
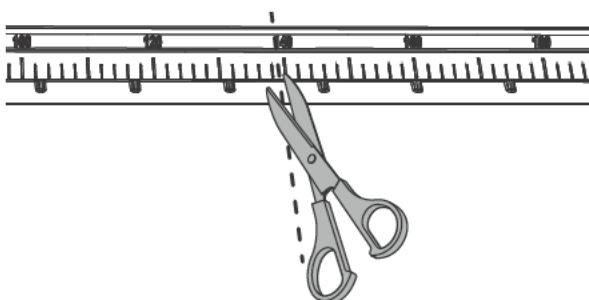

10**CHECK LEG TO LEG MEASUREMENTS**

With a Tape measure check leg to leg measurements are correct as per the table. Ensure measurements are taken from the centre of the Legs as shown.

LEG TO LEG MEASUREMENTS		
Front Bar	Middle Bar	Rear Bar
1045 mm	980 mm	940 mm

**11****BAR SLOT COVERS (OUTSIDE LEG)**

Measure the Bar channel outside of the Legs and subtract 20 mm from this measurement. Using the remaining pieces of Slot Cover from Step 9, cut to this length and insert into the underside channel of each Bar end as shown.

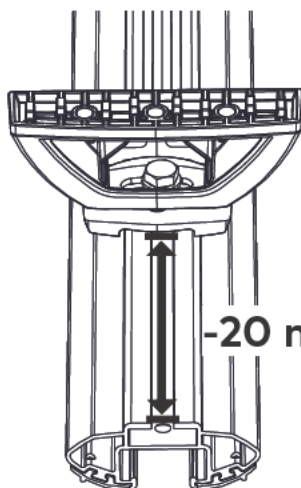
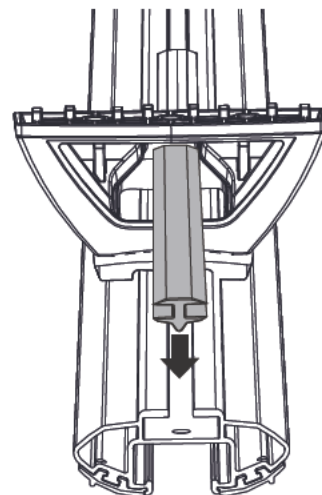
**-20 mm****12****SECURE END CAPS TO BARS**

Insert the End Caps as shown. A Rubber Mallet can be used to assist installation.

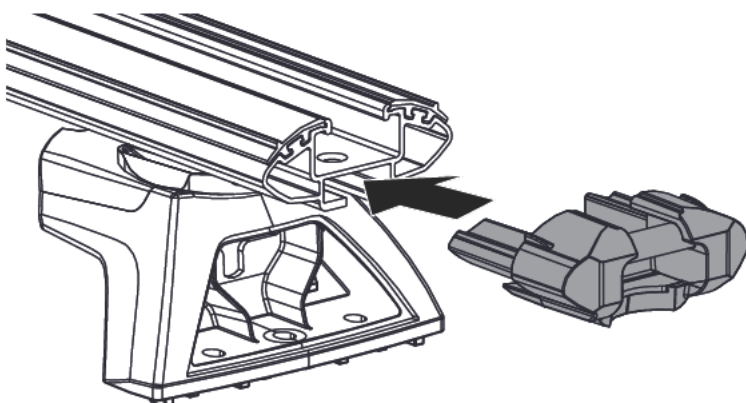
**13**

Secure using Plastite Screw (from LockNLoad Bar kit). Tighten using a #2 Phillips Head Screwdriver.

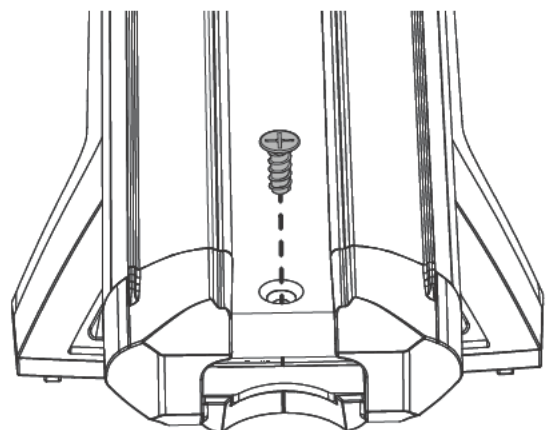

14

BAR FITMENT

Carefully place Bar assembly over Pads. **Take care not to damage vehicle.** Once positioned, locate the raised notches on base of Legs into the recesses on Pads. Repeat for all Bars.

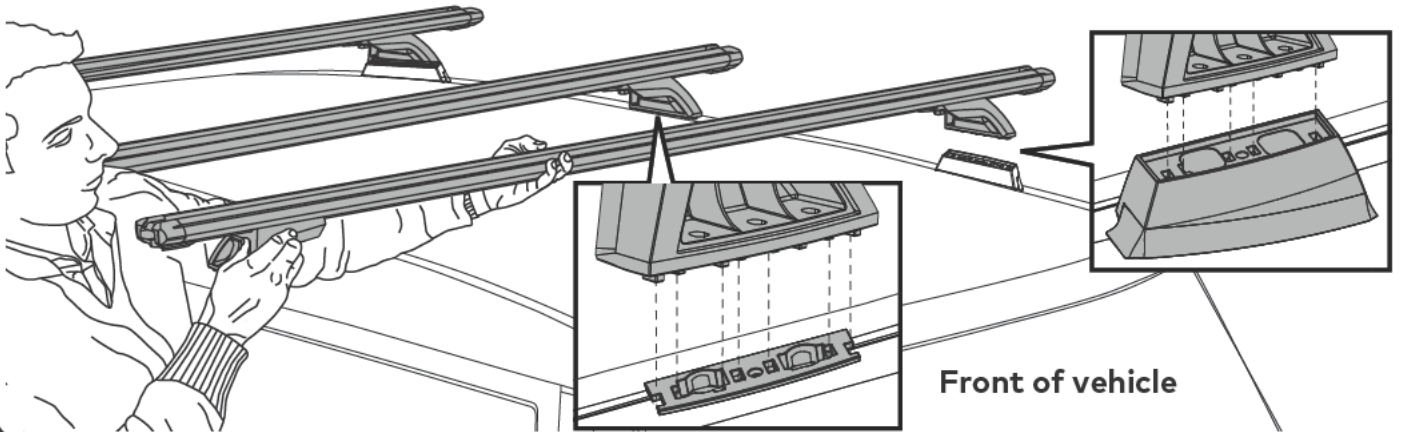

15

SECURE BARS TO PADS

From the LockNLoad Mounting kit, assemble 1 x M6 Washer onto each M6 Set Screw (30 mm and 20 mm) as shown. Insert through centre hole on Leg into Pad as per table.

Front Pads	M6 Set Screw 30 mm
Middle Pads	M6 Set Screw 20 mm
Rear Pads	M6 Set Screw 30 mm

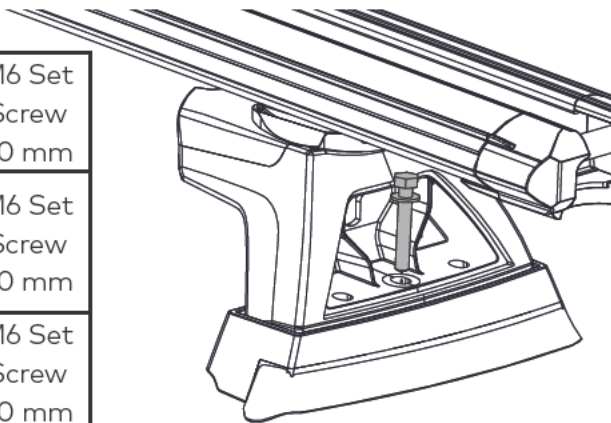

16

Tighten all M6 set screws to 7 Nm using 10 mm Open Ended Spanner.

Do not over tighten.

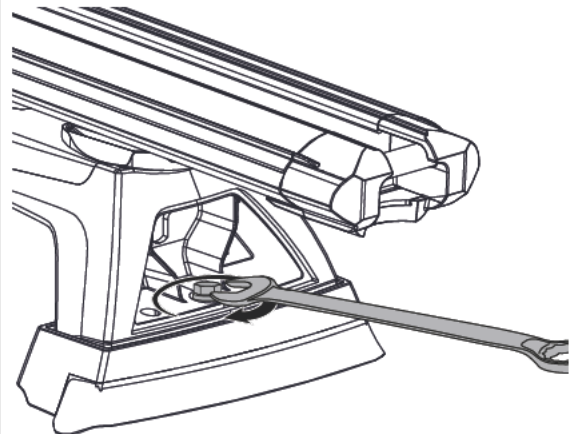

17

LEVEL BARS

With vehicle on a level surface, adjust all Bar angles to be level using a Spirit Level.

The Bar angle can be adjusted to reduce any wind noise. In most cases this is achieved by getting the Bar in-line with air flow parallel to the ground.

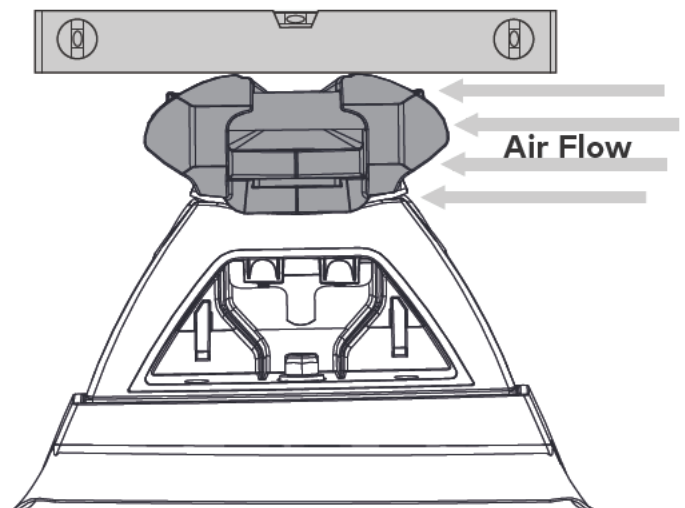

18**SECURE LEGS TO BARS**

Tighten all M8 Set Screws to 9 Nm using a 13 mm Spanner.

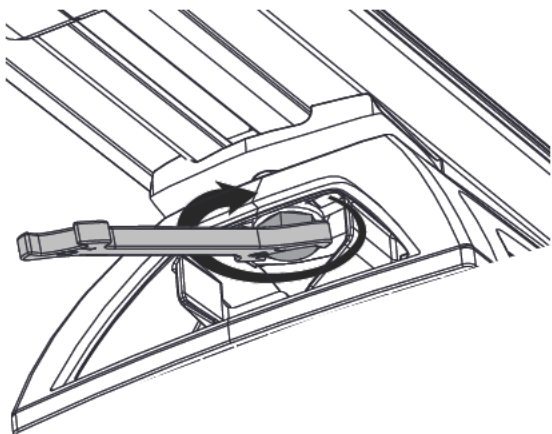
**19****CHECK BAR LEGS ARE SECURE**

Check all Bar Legs are secure.

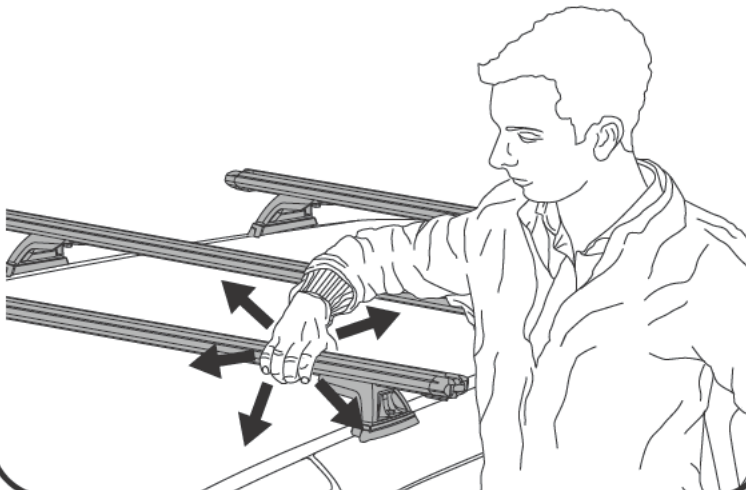
**20****FIT LEG COVERS**

Using the keys and Covers supplied in the LockNLoad Leg Kit, fit and lock all Leg Covers.

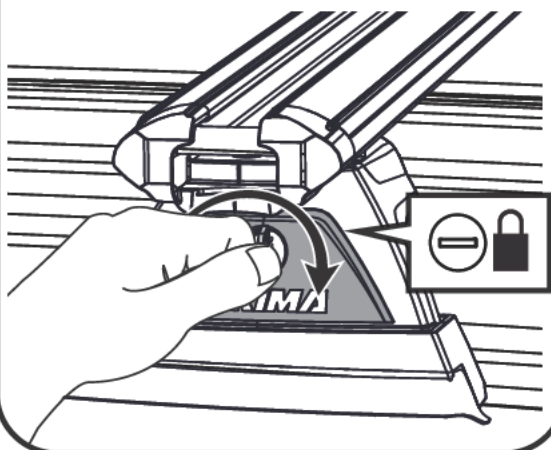
**21****BAR KEYS**

Place one key on the vehicle key ring and put the other away safely, or store with the spare vehicle key.

Write the key number (which is stamped on the key) in the box provided. Replacement keys are available from Yakima stockists, visit www.yakima.com.au or www.yakima.co.nz to find your nearest store or contact us directly on 1800 143 548 (AU) or 0800 4776 722 (NZ).

Key Number:

YAKIMA

www.yakima.com.au
www.yakima.co.nz
www.yakima.com
www.yakima.eu

YAKIMA AUSTRALIA PTY LTD

17 Hinkler Court
Brendale, QLD 4500
Australia
1800 143 548

YAKIMA PRODUCTS, INC.

4101 Kruse Way
Lake Oswego, OR
97035-2541
USA
888 925 4621